

**Supplement to  
Red Hill Bulk Fuel Storage Facility  
Administrative Order on Consent  
Tank Upgrade Alternatives and  
Release Detection  
Decision Document**



---

**August 2021  
Navy Region Hawaii**

This page intentionally left blank

Red Hill Administrative Order on Consent Tank Upgrade Alternative (TUA) and Release  
Detection (RD) Supplemental Document Deliverable

Section 3.5 TUA Decision Document and Implementation

Section 4.8 New Release Detection Alternatives Decision Document and Implementation

In accordance with the Red Hill Administrative Order on Consent, paragraph 9,  
DOCUMENT CERTIFICATION

I certify under penalty of law that this document and all attachments were prepared under my direction or supervision in accordance with a system designed to assure that qualified personnel properly gather and evaluate the information submitted. Based on my inquiry of the person or persons who manage the system or those persons directly responsible for gathering the information, the information submitted is, to be the best of my knowledge and belief, true, accurate, and complete. I am aware that there are significant penalties for submitting false information including the possibility of fines and imprisonment for knowing violation.

Signature:



CAPT James "Gordie" Meyer, CEC, USN Regional Engineer, Navy Region  
Hawaii

Date:

7/26/2021

This page intentionally left blank

# Executive Summary

## **Overview**

The U.S. Navy is committed to protecting our environment, national security, and the health of our communities. The Red Hill Bulk Fuel Storage Facility (the “Facility”) is critical to the national security of our nation, but we also take seriously our stewardship of the environment and protection of human health. The extensive work we’ve done, including plans to invest over \$470M through FY25, accomplishes all three of these goals. The water continues to be safe to drink and meets all federal and state standards, as confirmed by regular independent laboratory testing done on behalf of both the U.S. Navy and the Honolulu Board of Water Supply.

In September 2019, the U.S. Navy and the Defense Logistics Agency provided the *Tank Upgrade Alternatives (TUA) and Release Detection Decision Document* to the Environmental Protection Agency (EPA) and the Hawaii State Department of Health (DOH). This document summarized our approach to major upgrades at the Facility. It recommended Alternative 1A, a thorough and proven restoration of the existing tanks alongside layers of protection, as the Best Available Practicable Technology (BAPT) today. The Regulators responded to our TUA Decision Document with a series of questions, requests for information, and follow-on discussions.

This Supplement to the September 2019 TUA Decision Document is intended to answer those questions, and it adds detail and rationale that further support the recommendations. Detailed rationale is provided supporting Alternative 1A as protective of the environment and drinking water, but additionally we have added details on why other alternatives were not selected. Alternative 1A is a proven upgrade that is available today, and the Navy has committed to secondary containment in the future. The U.S. Navy has already identified and begun to evaluate a new potential secondary containment technology that is expected to be fully analyzed in the next TUA Decision Document (in accordance with the AOC, TUA decisions will be re-evaluated every five years).

The decisions made today and tomorrow on upgrades to this critical facility should be made maximizing the technologies and opportunities available. This includes an approval of Alternative 1A for upgrades that can be done today, and investments in secondary containment upgrades for tomorrow. While some have called this a decision between single-wall and secondary containment options, we should embrace both as investments in what is proven today and in what is possible for tomorrow. In committing to the protection of our environment, national security, and the health of our communities, the Navy therefore recommends the staged approach in both types of technologies as the best way to achieve these goals.

## **Background**

In 2015, the U.S. Navy and the Defense Logistics Agency entered into an Administrative Order on Consent (AOC) with the Environmental Protection Agency (EPA) and the Hawaii State Department of Health (DOH) to address “actions to minimize the threat of future releases in connection with the field-constructed bulk fuel underground fuel storage tanks, pumps, and

associated piping at the Red Hill Bulk Fuel Storage Facility.” The AOC further established a detailed process for performing investigations, collecting, and analyzing data, and implementing technical solutions to focus on continued safe operations at the Facility, while protecting the environment and the water. Attached to the AOC is a Statement of Work (SOW), consisting of eight sections describing the work that will be conducted.

Section 2 of the AOC SOW requires the development of tank inspection, repair, and maintenance (TIRM) procedures “that can be applied to the in-service Tanks at the Facility to prevent releases into the environment.” EPA and DOH approved the AOC SOW Section 2.4 TIRM Decision Document (NAVFAC EXWC 2017) in 2017. The TIRM Decision Document includes a variety of improved processes that the AOC Regulators (Environmental Protection Agency [EPA] and Hawaii State Department of Health [DOH]) agreed will “improve the performance, reliability and integrity” of the existing tanks (EPA Region 9 and DOH 2017). These improved processes will help prevent an incident like the 2014 Tank 5 release from recurring.

Section 3 of the AOC SOW was established “to identify and evaluate the various tank upgrade alternatives (TUA) and then select and implement” the Best Available Practicable Technology (BAPT).

### **Best Available Practicable Technology**

During the initial scoping for the TUA analyses in 2016, the Navy, EPA, DOH, and many other subject matter experts considered a range of possibilities. All parties agreed upon six (6) potential upgrade alternatives that would be subject to further analyses:

- Alternative 1A - Restoration of Existing Tank
- Alternative 1B - Restoration of Existing Tank plus Interior Coating
- Alternative 1D - Remove Existing Steel Liner, Install New Steel Liner with Interior Coating
- Alternative 2A - Composite Tank (Double Wall) Carbon Steel with Interior Coating
- Alternative 2B - Composite Tank (Double Wall) Stainless Steel
- Alternative 3A - Tank within a Tank (Carbon Steel), full Interior and Exterior Coating

These potential alternatives were analyzed in the AOC SOW Section 3.3 *Tank Upgrade Alternatives* report (the “TUA Report”) (DON 2017a). The TUA Report included a detailed assessment of each alternative based on 18 attributes. The EPA and DOH approved the TUA Report on May 21, 2018 (EPA Region 9 and DOH 2018). Since that time, the Navy has continued to evaluate potential upgrade alternatives.

Based on the work that began with the TUA Report, the AOC SOW calls for development of a decision document to select the BAPT that can be used to upgrade the existing tanks. The AOC SOW defines BAPT as “the release prevention methods, equipment, repair, maintenance, new construction, and procedures, or any combination thereof, that offers the best available protection to the environment and that is feasible and cost-effective for the tanks at the Red Hill Facility.” The AOC instructs the Navy to consider risks and benefits, technical feasibility and requirements,

the anticipated operational life, and costs, and comments that “Reliance on any one of these factors to the exclusion of other factors is inappropriate.”

### **Tank Upgrade Alternative and Release Detection Document**

Based on these criteria, on September 9, 2019, the Navy submitted the AOC SOW *Tank Upgrade Alternatives and Release Detection Decision Document* (the “TUA Decision Document”) (DON 2019c) for EPA and DOH review. The 2019 TUA Decision Document recommended implementation of Alternative 1A and presented the results of additional analyses conducted since the 2017 TUA Report. Alternative 1A is a thorough and proven restoration of the existing tanks alongside layers of protection.

In a letter dated October 26, 2020, EPA and DOH responded that the TUA Decision Document did not provide sufficient detail supporting its BAPT recommendation. EPA and DOH requested amplifying information on the proposed TUA decision (EPA Region 9 and DOH 2020c). The letter listed multiple topics and questions for the Navy to address before the EPA and DOH could further evaluate the recommended TUA decision. Working with the EPA and DOH, the Navy integrated these comments into 16 Requests for Information (RFIs).

### **Tank Upgrade Alternative Supplement**

This TUA Supplement addresses those 16 RFIs and summarizes the findings of the previous TUA Report, the TUA Decision Document, and also presents additional information and analyses conducted over the last 19 months since the previous TUA documents were completed. In developing this TUA Supplement, the Navy carefully considered (1) all related reports regarding technology, operations, and environmental conditions at Red Hill, (2) ongoing research and development and technology evaluation efforts, (3) EPA and DOH informational needs to support the TUA decision, and (4) public comments on the TUA Decision Document received by the EPA and DOH.

Part I of this TUA Supplement describes the BAPT evaluation process and recommended TUA decision, and it details how the Navy’s system-of-systems at the Red Hill Facility is protecting and will continue to protect the drinking water.

Part II provides detailed Navy responses to each of the 16 RFIs. It includes information that demonstrates that the proposed TUA decision will continue to further protect groundwater resources.

Part III contains additional supporting material that is intended to help the EPA and DOH evaluate the recommended TUA decision.

### **BAPT Recommendation**

As described in this TUA Supplement, the only alternative that meets BAPT requirements today is Alternative 1A. The other alternatives do not meet the BAPT requirements. The TUA Report, TUA Decision Document, and this Supplement demonstrate how the multiple release prevention,

detection, and mitigation measures included within Alternative 1A are the best technologies that can be employed today to protect the environment, particularly groundwater and drinking water. Taken as a whole, these measures would have prevented the 2014 release and are completely compatible with the future identification and installation of new secondary containment, unlike the other alternatives currently under consideration. As an overview of the shortcomings of the other alternatives:

- Regarding Alternative 1B, further research and analyses conducted since the 2017 TUA Report and 2019 TUA Decision Document have shown that there is no potential interior epoxy coating (which is all that distinguishes Alternative 1B from 1A) that can provide protection against backside corrosion or serve as a hydraulic barrier, as had originally been hoped. Thus, Alternative 1B cannot currently achieve its stated purpose of providing additional containment. In addition, evaluations conducted over the past several years indicate that application of the epoxy coating would require an additional 18 months to upgrade each tank.
- Alternative 1D would require the forcible dismantling of existing concrete and steel supporting infrastructure, which could affect structural integrity and adversely impact long-term reliability. This alternative could therefore increase rather than decrease risk.
- Alternatives 2A and 2B would continue to rely upon the integrity of the existing tank structure but would negate the ability to regularly test or repair the steel liner and underlying concrete, calling into question that alternative's long-term effectiveness and reliability, and making the approved TIRM procedures impossible to implement.
- Alternative 3A involves similar problems by relying on existing infrastructure, and analyses described in this TUA Supplement indicate that this alternative could result in impermissible health and safety risks for the workers at the Red Hill Facility.
- Additionally, Alternatives 1D, 2A, 2B, and 3A would also require an irreversible commitment of resources that is not compatible with (and therefore could preclude) the Navy's commitment to the future installation of a completely new and potentially much more reliable secondary containment solution, which the Navy is currently investigating.

For these reasons, Alternative 1A remains the current option most compatible with ultimately achieving a permanent secondary containment solution, which would be above and beyond the currently identified TUA alternatives. However, while the Navy has begun to actively evaluate that potential future alternative by commissioning a feasibility study (which will be followed by assessment of that study, development of a conceptual design, and pilot project construction and testing). It will take time to complete those steps before this potential secondary containment solution can be considered as a TUA alternative in the next 5-year TUA decision document.

An important consideration in evaluating the current TUA recommendation is recognition that the AOC envisions a long-term, ongoing process to ensure continued upgrading of the tanks with the best available and practicable technologies. This is why Section 3.7 of the AOC SOW calls for "a re-evaluation of new technologies to determine if either BAPT or the TIRM procedures, or both, should be modified" every five years. This 5-year review and implementation cycle does not begin until after the approval of the initial TUA Decision. Therefore, the current TUA recommendation is not the final tank upgrade solution, but is rather a step toward other improvements, including but



not limited to implementation of the aforementioned appropriate secondary containment technology. While there is a 5-year review applied to BAPT, there would be no intent to wait the full five years if studies showed promise prior to that timeframe, so five years should only be considered the maximum time between BAPT determinations.

### **Path Forward**

The U.S. Navy remains firmly committed to the AOC process and shares EPA's and DOH's mission to protect the drinking water. Approval of this first TUA Decision Document is an important action in support of that mission. The Navy does not recommend any further delays in this TUA decision, because that could hamper completion of BAPT implementation within the timeline set forth in the AOC and described in this document.

The Navy is also already exploring future options, engaging with the University of Hawaii's Applied Research Lab and other leading experts and engineering organizations for ongoing research and technology evaluations for new products and technologies that may become available and practicable at a future date.

The recommended Alternative 1A consists of a Regulator-approved tank restoration process and includes three categories of protection (prevention, detection, and mitigation) that are holistically integrated to prevent releases and help ensure that human health, the environment, and the drinking water remain protected and that our water remains safe to drink. While the Navy strives for zero releases (all data indicate there has been no further release of fuel since 2014), the system-of-systems of release prevention, detection, and mitigation measures employed at the Red Hill Facility help prevent releases and the potential impact to groundwater. Taken together, the environmental data and the system-of-systems demonstrate that the drinking water is currently protected and will remain protected.

The Navy is also committed to upgrading the Red Hill tanks with secondary containment by July 15, 2045, which in our current study includes a reliable inner and outer barrier with an interstitial space that can be effectively monitored for and contain any hypothetical release. While investigation of the potential secondary containment solution appears promising, there is currently no practicable way to provide secondary containment measures to the Red Hill fuel tanks today until the required studies, designs, and mandatory federal funding processes are completed. Until such time that a new secondary containment alternative is available and practicable, the layers of protection provided by the BAPT outlined in the 2019 TUA Decision Document are the best practicable measures currently available. Full investment in the technologies of Alternative 1A is absolutely necessary for implementation today to help ensure maximum possible tank safety while we thoroughly explore prospective secondary containment solutions currently under exhaustive study for future BAPT implementation. This combination of solutions represents the best and most comprehensive coverage for ensuring the shared goals of protecting the environment, the drinking water, community health, and national security today and tomorrow.

This page intentionally left blank

# Table of Contents

<b>Document Certification</b>	3
<b>Executive Summary</b>	5
<b>Table of Contents</b>	11
<b>I Summary of the Current BAPT Recommendation</b>	15
1 Introduction	17
2 BAPT and Alternative Evaluation Criteria	20
3 Current Analysis of TUA Alternatives Relative to BAPT Requirements	22
4 Recommended TUA Decision (Alternative 1A)	26
5 Evolving TUA Process and Addressing Secondary Containment	33
6 Addressing Public Comments	36
7 Conclusions	37
<b>II Responses to RFIs</b>	41
Response to RFI 1: How the Proposed Tank Upgrade Alternative (TUA) Decision Protects Drinking Water	43
Response to RFI 2: Performance of TUA Alternatives in Achieving BAPT	69
Response to RFI 3: Analysis of TUA Alternatives and Related Information	73
Response to RFI 4: Evaluation of Hydraulically Protective Tank Coatings	87
Response to RFI 5: Upgrading Tanks to Secondary Containment by July 15, 2045	89
Response to RFI 6: Justification of the Selected Combination of Release Detection Systems	93
Response to RFI 7: Integration of Release Detection Systems	107
Response to RFI 8: Effectiveness of Improvements to the Release Detection Systems	121
Response to RFI 9: Concentration Criteria and Trend Analysis for Soil Vapor Monitoring	123
Response to RFI 10: Update on the Continuous Soil Vapor Monitoring Pilot Test	135
Response to RFI 11: Red Hill Response Action Plans	139
Response to RFI 12: Minimal Contamination Would Result from a Hypothetical Minor Release	155

Response to RFI 13: Significance of Hypothetical Slow Releases	163
Response to RFI 14: Response Actions and Related Environmental Impact from a Significant Release	167
Response to RFI 15: Expanded Navy Red Hill Website	173
Response to RFI 16: Navy's Strategy for Water Protection	177
<b>III Appendices</b>	<b>183</b>
Appendix A: AOC SOW Section 5.4 Execution Plan, Decision on Need for and Scope of Modified Corrosion and Metal Fatigue Practices	185
Appendix B: Red Hill Fuel Storage Facility (RHFSF) Response Plan	281
Appendix C: Tank Drain-Down Plans at Hypothetical Release Rates	499
Appendix D: Bounding Estimates of Hypothetical Release Volumes	503
Appendix E: Immediate Response Actions	509
Appendix F: Acronyms, Abbreviations, and Initializations	513
Appendix G: References	517

## Figures

### PART I:

Figure 1: Soil Vapor Monitoring Network Underneath the Red Hill Fuel Storage Tanks	29
Figure 2: Bow-Tie Diagram for Alternative 1A – Environmental Risk Management	32
Figure 3: Proposed BAPT Implementation Schedule as Part of the Clean, Inspect, and Repair Process	34

### PART II:

RFI 1 Figure 1: Bow-Tie Diagram for Alternative 1A – Environmental Risk Management	67
RFI 3 Figure 1: Proposed BAPT Implementation Schedule as Part of the Clean, Inspect, and Repair Process	83
RFI 6 Figure 1: Red Hill Groundwater Monitoring Network Before and After the 2014 Tank 5 Release	101
RFI 6 Figure 2: Expansion of the Red Hill Groundwater Monitoring Well Network Following the 2014 Tank 5 Release	103
RFI 7 Figure 1: Event Sequence Diagram for Tank Releases Directly to Rock	111

RFI 7 Figure 2: Event Sequence Diagram for Releases Resulting from Overfilling a Tank	115
RFI 7 Figure 3: Example Unscheduled Fuel Movement (UFM) Report	118
RFI 7 Figure 4: Example Confirmed Release Notification Form	119
RFI 9 Figure 1: Soil Vapor Monitoring Network Underneath the Red Hill Fuel Storage Tanks	125
RFI 9 Figure 2: Soil Vapor Response Under Tank 5 After the January 2014 Release	126
RFI 9 Figure 3: Maximum PID Reading (Excluding Tank 5) for Each Monitoring Event, March 2008 – December 2020	129
RFI 9 Figure 4: Maximum PID Reading (Tanks 15 and 16) for Each Monitoring Event, March 2008 – December 2020	130
RFI 9 Figure 5: Average PID Readings Over Time, 2008–2020	131
RFI 11 Figure 1: Tank 5 AHFE Alarm Set Points	142
RFI 11 Figure 2: Tank 15 AHFE Alarm Set Points	143
RFI 11 Figure 3: Event Sequence Diagram for Tank Release Directly to Rock	145
RFI 11 Figure 4: Event Sequence Diagram for Release Resulting from Overfilling a Tank	149

## Tables

### PART II:

RFI 1 Table 1: Attribute Ratings for Each TUA Alternative	47
RFI 3 Table 1: Red Hill Facility Clean, Inspect, and Repair Schedule	84
RFI 7 Table 1: Confirmed Release Notification Requirements and Timelines	119
RFI 11 Table 1: Summary of Four Release Scenarios Developed for Bounding Estimates	150

This page intentionally left blank

# I Summary of the Current BAPT Recommendation

This page intentionally left blank



# 1 Introduction

This Supplement to the Red Hill Bulk Fuel Storage Facility Administrative Order on Consent (AOC) Statement of Work (SOW) Sections 3.5 and 4.8 *Tank Upgrade Alternatives (TUA) and Release Detection Decision Document* (herein referred to as the “TUA Decision Document”) was developed to further support the Navy decision for the current most environmentally protective TUA that meets Best Available Practicable Technology (BAPT). This TUA Supplement is based on: (1) The *Tank Upgrade Alternatives* report (herein referred to as the “TUA Report”) (DON 2017a) that was approved by the AOC Regulatory Agencies (EPA Region 9 and DOH 2018); (2) the TUA Decision Document (DON 2019c); (3) ongoing research and technology evaluation efforts since the 2017 and 2019 reports; (4) ongoing AOC efforts related to environmental studies; and (5) the AOC Regulatory Agencies’ October 26, 2020 Notice of Deficiency letter for the TUA Decision Document (EPA Region 9 and DOH 2020c) (herein referred to as the “Agencies’ TUA Letter”).

The Agencies’ TUA Letter stated “... *the TUA Decision Document lacks detail, clarity, rationale and justification to demonstrate that the actions described in the Decision Document are the best available practicable technology ("BAPT") for the tanks and operations at the Red Hill facility.*” The letter also listed a series of comments to better support the TUA decision as well as a section on Agency responses to public comments.

The Navy carefully considered the Agencies’ comments and further broke them down into 16 Requests for Information (RFIs) to be able to effectively address the Agencies’ concerns described in the letter. Part II of this TUA Supplement provides detailed Navy responses to each of the 16 RFIs that further support the Navy’s current TUA decision by providing additional details, clarity, rationale, and justification for (a) determination of BAPT and (b) selection of the current TUA. Finally, this document also addresses the public comments that were provided by the AOC Regulatory Agencies.

The Navy remains committed to the AOC and will implement that BAPT decision for all Red Hill fuel tanks by the 2037 AOC deadline. One of the most important aspects of this TUA Supplement is the fact that the Navy has made an additional commitment to upgrade all Red Hill tanks with secondary containment, including an inner and outer barrier with an interstitial space that is monitored for releases, by July 15, 2045. This is above and beyond the current BAPT decision contained in the 2019 TUA Decision Document.

As part of the AOC, TUA Decision Documents are updated every five (5) years for consideration of new BAPT that may be the result of ongoing research and development and new product development. This means that the TUA alternative may change over time as a function of how BAPT evolves. Selection of the current and intermediate BAPT, as part of the 5-year TUA Decision Document cycle, needs to be consistent and compatible with the Navy’s commitment to upgrade the tanks with secondary containment by July 15, 2045. Any tank that does not have the appropriate secondary containment by that time will be removed from service until it can be upgraded.

As part of the TUA decision process, the Navy is committed to the continued protection of the environment with a focus on protection of groundwater beneath Red Hill and the associated drinking water supply wells located in the area around Red Hill. In this regard, the Navy has developed a “system-of-systems” that focuses on (1) release prevention, (2) release detection, and (3) release mitigation. Release prevention measures are designed to further reduce the probability of any release from occurring. The 2014 Tank 5 release (which was related to human error and not corrosion) has been addressed through enhanced operational practices. Updated release prevention measures make the probability of any release similar to the 2014 release unlikely. These measures also make the probability of a more significant release (that could impact drinking water) unlikely. Even if a release were to occur, a range of release detection systems is in place (as well as additional systems that are in the evaluation stage) that would provide early detection before a significant size release could occur. Finally, even if a release were to occur, a series of mitigative measures are designed to reduce the consequence of a release and protect the drinking water. All these measures, taken together, provide a layered and reliable system that is designed to protect the environment and drinking water as the Navy’s safe operation of the Facility continues.

### **1.1 AOC Section 2 and 3**

Section 3 of the AOC SOW was established “to identify and evaluate the various TUA alternatives and then select and implement” the BAPT and tank inspection, repair, and maintenance (TIRM) procedures “that can be applied to the in-service Tanks at the Facility to prevent releases into the environment.” The Environmental Protection Agency (EPA) and the Hawaii State Department of Health (DOH) approved the AOC SOW Section 2.4 TIRM Decision Document (NAVFAC EXWC 2017) in 2017. The TIRM Decision Document includes a variety of improved processes that the Regulators agreed will “improve the performance, reliability and integrity” of the existing tanks (EPA Region 9 and DOH 2017). These improved processes will help prevent an incident like the 2014 Tank 5 release from recurring.

During the initial scoping for the TUA analyses, the Navy, EPA, DOH, and a host of subject matter experts considered a range of possibilities and agreed upon six potential upgrade alternatives that would be subject to further analyses:

- Alternative 1A - Restoration of Existing Tank
- Alternative 1B - Restoration of Existing Tank plus Interior Coating
- Alternative 1D - Remove Existing Steel Liner, Install New Steel Liner with Interior Coating
- Alternative 2A - Composite Tank (Double Wall) Carbon Steel with Interior Coating
- Alternative 2B - Composite Tank (Double Wall) Stainless Steel
- Alternative 3A - Tank within a Tank (Carbon Steel), Full Interior and Exterior Coating

These potential alternatives were analyzed in the AOC SOW Section 3.0 TUA Report (DON 2017a). The TUA Report assessed the six alternatives based on 18 attributes, which are discussed further in the Responses to RFIs (Part II of this TUA Supplement). The TUA Report was approved by EPA and DOH in 2018 (EPA Region 9 and DOH 2018). Since that time, the Navy has continued to further evaluate potential upgrade alternatives.

Based on the analyses in the TUA Report and subsequent information gathered since 2017, the Navy/DLA submitted the TUA Decision Document (DON 2019c) to the Regulatory Agencies for review and approval on September 9, 2019. The TUA Decision Document recommended Alternative 1A as the only alternative currently meeting BAPT and ready to be implemented starting in the first 5-year TUA decision cycle.

The Agencies' TUA letter dated October 26, 2020 stated that the TUA Decision Document did not provide sufficient detail demonstrating that its recommendation is currently the BAPT for protecting groundwater resources in the area, and therefore refrained from weighing in on the proposed TUA until further information was provided (EPA Region 9 and DOH 2020c). The Agencies' TUA Letter listed a series of comments to better support the TUA decision. In this letter, 16 categories of comments were described that the Navy would need to address before EPA and DOH could further evaluate the recommended TUA decision. The Navy refers to these 16 categories as requests for information (RFIs).

This TUA Supplement was developed to provide additional information that addresses the 16 RFIs and public comments, and further supports the Navy's recommended decision for the current most protective TUA that meets the BAPT criteria. In developing this TUA Supplement, the Navy carefully considered: (1) all related reports regarding technology, operations, and environmental conditions at Red Hill; (2) ongoing research and development and technology evaluation efforts; (3) the Agencies' informational needs to support the TUA decision; and (4) public comments on the TUA Decision Document received by the Regulatory Agencies.

Part I of this TUA Supplement (Summary of the Current BAPT Recommendation) provides an overview of the TUA selection process, a summary of the BAPT currently recommended for implementation, and description of how the currently recommended TUA, including its system-of-systems of release prevention, detection, and mitigation safeguards, will continue to protect human health and the environment.

Part II of this TUA Supplement (Responses to RFIs) presents the Navy's detailed responses to each of the 16 RFIs that further support the Navy's current TUA decision by providing additional details, clarity, rationale, and justification for (a) determination of BAPT, (b) selection of the current TUA alternative, and (c) environmental protection.

## **1.2 TUA Report / Alternatives**

Section 3.3 of the AOC SOW requires a report to identify and evaluate various TUA alternatives that can be applied to the tanks at Red Hill. During scoping sessions in 2015 between the AOC Regulators, the Navy, DLA, and other experts, an initial list of over 30 tank upgrade alternatives was evaluated and initially reduced to 13 and finally to 6 alternatives that were then considered capable of potentially being applied to the tanks at Red Hill to reduce the risk of releases to the environment while maintaining operational capabilities. The TUA Report (DON 2017a) presented and evaluated these six tank upgrade alternatives (three single-wall and three double-wall/secondarily contained tank options). The TUA Report was approved by the Agencies in a letter dated May 21, 2018 (EPA Region 9 and DOH 2018). The six TUA alternatives are:

- Alternative 1A - Restoration of Existing Tank
- Alternative 1B - Restoration of Existing Tank plus Interior Coating
- Alternative 1D - Remove Existing Steel Liner, Install New Steel Liner with Interior Coating
- Alternative 2A - Composite Tank (Double Wall) Carbon Steel with Interior Coating
- Alternative 2B - Composite Tank (Double Wall) Stainless Steel
- Alternative 3A - Tank within a Tank (Carbon Steel), Full Interior and Exterior Coating

## 2 BAPT and Alternative Evaluation Criteria

The AOC SOW defines BAPT as:

*“...the release prevention methods, equipment, repair, maintenance, new construction, and procedures, or any combination thereof that offers the best available protection to the environment and that is feasible and cost-effective for the Tanks at the Red Hill Bulk Fuel Storage Facility (RHBFSF). The selection and approval of BAPT, under both the Navy TUA Decision and Regulators’ review, shall be based on, but not be limited to, consideration of the following factors: (1) the risks and benefits of the particular technology; (2) the capabilities, feasibility, and requirements of the technology and facilities involved; (3) the anticipated operational life of the technology; and (4) the cost of implementing and maintaining the technology. Reliance on any one of these factors to the exclusion of other factors is inappropriate.”*

As summarized in the following subsections, the TUA Report and the TUA Decision Document evaluated each of the six potential alternatives based upon these criteria.

### 2.1 BAPT Evaluation Factors

The Navy’s 2017 TUA Report identified and developed 18 specific attributes to help assess the six potential TUA alternatives. Each alternative was rated on a qualitative scale for each attribute. Part D of the TUA Report defines each attribute and describes the rating system for each of the alternatives. The attributes included in the analysis were:

1. **Constructible:** Alternative can be constructed in field at the Red Hill Facility using practicable construction means and methods. Practicable must recognize the difficulty in bringing construction materials into the tanks through the limited-access upper tunnel, or other methods as may be developed for individual alternatives, as well as the degree of difficulty in accessing the tank surfaces for the inspection and repair process.
2. **Testable:** Alternative can be tested and shown acceptable during construction prior to filling and during startup/commissioning when filling.
3. **Inspectable:** Alternative can be inspected to determine integrity on a periodic basis while tank is in or out of service.
4. **Repairable:** Alternative can be repaired in field at the Red Hill Facility using standard traditional construction/repair means and methods.
5. **Practicable:** Alternative can be done or put into practice successfully in the time frame required by the Red Hill AOC SOW given the confines and associated infrastructure of the

Red Hill Facility with reasonable expectations that meet stakeholder cost/benefit analysis parameters.

6. **Corrosion Damage Mechanism:** Alternative has a coating system that provides corrosion protection or is constructed of a corrosion resistant material.
7. **Successful Implementation Elsewhere:** Alternative has been put into place at other large fuel depots and is successful in preventing releases to the environment and/or detecting releases.
8. **Reliability:** Ability of alternative to perform its required function (i.e., safely contain fuel) under stated conditions for a specified minimum period, which is defined as the next out-of-service internal inspection interval.
9. **Impact on Storage Volume:** If the alternative results in a reduction in volume, the reduction is presented as a percent reduction in volume compared to the existing overall facility volume.
10. **Provides Secondary Containment:** Alternative provides secondary containment of a release from the primary tank. The primary tank is the wall of the tank that provides primary containment, e.g., the wall of a single-wall tank or the inner wall of a double-wall tank.
11. **Dependency on Existing Steel Tank Liner:** Alternative is not dependent on the hydraulic integrity of the existing tank liner to contain fuel (primary tank) or provide a barrier between a breach of the primary tank, and the environment (i.e., interstitial space boundary, or dike wall/floor secondary containment boundary).
12. **Release Detection Integral to Construction:** Alternative has release detection capability that is integral (i.e., is physically part) of the upgrade construction, such as an interstitial space with monitoring or visible/inspectable space such as a dike surrounding the tank. The complexity and ability to confirm integrity of the system are factored into the rating of the alternative.
13. **Testing and Commissioning Procedures:** Alternative does not require a rigorous level of testing and commissioning procedures to return the tank to service. "Placing the tank in service" refers to actions necessary for the initial filling with fuel, performing commissioning steps and confirming the tank repair process was successful and declared liquid-tight and suitable for transferring custody to the operator for use.
14. **TIRM Requirements for Inspection and Repair of Existing Tank prior to Application of Upgrade:** Alternative requires a level of inspection and repair of existing tank as specified in the AOC SOW Section 2.2 TIRM Procedures Report, Appendix BD: UFGS 33 56 17.00 20-Inspection of Fuel Storage Tanks and Appendix BE: 33 56 18.00 20-Repair of Red Hill Fuel Storage Tanks (NAVFAC EXWC 2016).
15. **TIRM Requirements for Future Integrity Inspections:** Alternative does not require rigorous level of inspection and/or access provisions to complete integrity inspections and tank maintenance.
16. **Impact on Operating and Maintenance Requirements and Procedures:** Current means of filling, emptying, or management of a static tank condition, or tank periodic testing is not impacted by the alternative upgrade.
17. **Tank Upgrade Construction Cost Estimate (Planning Level):** A construction cost estimate of one tank constructed as part of a multi-tank repair contract, excluding government costs, design costs, construction contingencies, inspection costs, and release detection system costs.

**18. Tank Upgrade Duration:** An estimated time to complete one tank upgrade and combinations of tank upgrades including typical government contracting time requirements as compared to the prerequisite timeframe set by the Red Hill AOC SOW (September 28, 2037).

The TUA Report conducted detailed analyses but did not make a recommendation whether to implement any given TUA. In addition, it is important to bear in mind that the Navy has continued to conduct additional studies and evaluations in the nearly four (4) years since the TUA Report was submitted. The TUA Report and the additional subsequent considerations are summarized in the Responses to RFIs 1 and 2 (Part II).

## **2.2 Summary of Evaluation of Each Alternative**

As summarized in the Response to RFI 1, the TUA Report evaluated each attribute for all six alternatives. Part E of the TUA report presents a detailed discussion and ratings of each of the alternatives. Part F of the TUA report contains a BAPT Tank Upgrade Matrix summarizing the ratings. Each attribute was qualitatively rated in the following manner:

- Meets Criteria (MC)
- Mostly Meets Criteria (MMC)
- Somewhat Meets Criteria (SMC)
- Mostly Does Not Meet Criteria (MDNMC)
- Does Not Meet Criteria (DNMC)

The initial evaluation of the alternatives conducted in 2017 concluded that Alternatives 1A and 1B met critical BAPT criteria, while the other alternatives had a range of shortcomings. However, information gathered, and testing conducted since that time (and since the TUA Decision Document was submitted in 2019) has allowed for additional important considerations regarding several key attributes, as described below. Similarly, Appendix C of the TUA Decision Document outlined various other considerations as part of the Tank Upgrade Alternatives Comparison.

The following discussion provides an updated evaluation of the key factors relative to screening determination of BAPT (in addition to what has already been provided in the TUA Report and the TUA Decision Document) and focuses on the principal reasons why certain alternatives do not meet BAPT requirements.

## **3 Current Analysis of TUA Alternatives Relative to BAPT Requirements**

Detailed discussions relating to BAPT considerations relative to the six TUA Alternatives are provided in the Navy's Responses to RFIs 1 and 2 (Part II of this Supplement). The multiple layers of release prevention, detection, and mitigation measures included within Alternative 1A are the best technologies that can be employed today to protect the environment, particularly groundwater and drinking water. Taken as a whole, these measures would have prevented the 2014 release and are completely compatible with the future identification and installation of new secondary containment, unlike the other alternatives currently under consideration.

The key reasons why TUA Alternatives 1B through 3A do not meet BAPT requirements are summarized below.

### **3.1 Reasons for Alternative 1B (Restoration of Existing Tank plus Interior Coating) Not Meeting BAPT**

During the 2015 scoping sessions for the TUA decision process, it was suggested that an interior coating might exist that could both (1) constitute a hydraulic barrier capable of preventing releases in the hypothetical event of a hole in the liner and (2) provide protection against corrosion. However, in the time since the TUA Report and TUA Decision Documents were completed, it has been determined that no available interior commercial coating can provide a hydraulic barrier or prevent backside corrosion. Therefore, Alternative 1B is no longer considered a viable alternative capable of achieving its goals, and thus cannot be the BAPT. In addition, even if it were possible, Navy evaluations over the past several years indicate that application of the epoxy coating would require an additional 18 months per tank upgrade.

### **3.2 Reasons for Alternative 1D (Remove Existing Steel Liner, Install New Steel Liner with Interior Coating) Not Meeting BAPT**

Alternative 1D would require forcibly removing the existing steel liner plates from the backing, including concrete and metal support structures, which would risk structural damage of the overall system. In addition, this alternative could provide a new corrosion mechanism by introducing new material in contact with the existing concrete. Furthermore, the extent that the steel plates were attached to the concrete was previously underestimated. After removing coupons from Tank 14 for the AOC SOW Section 5.3.3 *Destructive Testing Results Report* (DON 2019b) and during actual repair work, the feasibility of Alternative 1D was found to be much more challenging than originally anticipated because many areas of the liner are in intimate contact with the underlying concrete and steel. Forcible detachment of the liner from the underlying concrete and steel could weaken the overall structure and is not recommended.

### **3.3 Reasons for Alternative 2A (Composite Tank (Double Wall) Carbon Steel with Interior Coating) Not Meeting BAPT**

There are several important reasons related to the constructible, reliable, inspectable, and repairable attributes that result in this alternative not meeting BAPT requirements. Perhaps most importantly, if Alternative 2A were implemented, it would continue to rely upon the existing steel liner for containment. However, unlike Alternative 1A, the existing steel lining would no longer be capable of being inspected or repaired once the new interior lining was installed and the interstitial space was filled with concrete. As a result, the approved AOC SOW Section 2 TIRM procedures could not be implemented, and the existing liner could not practicably be inspected and repaired within the required time frames, without (repeatedly) forcibly dismantling the structure. Thus, the following attributes would be significantly impacted:

- **Constructible.** In the Agency-approved TUA Report, Alternative 2A was considered to have somewhat met the criterion; however, the limited available access makes unproven

construction techniques at the Red Hill Facility problematic. Access to the Red Hill tanks is limited to an 8-foot-wide opening entering the tank.

- **Inspectable.** The exterior wall could not be inspected or repaired once the second wall is constructed inside the tank and concrete is used to fill the space between the layers.
- **Repairable.** For the same reason that the outer wall is not able to be inspected as described above, the outer wall of the double wall would not be repairable.
- **Reliable.** The lack of the ability to both inspect and repair the outer wall of this alternative impacts longer-term reliability and prevents the use of the AOC-approved TIRM process on the outer wall. Due to access constraints as discussed under the constructible section, materials must be brought inside the tank in smaller sizes, requiring a greater number of welds. This greater number of welds increases the likelihood of a weld failure that could result in a release, further reducing reliability.

Based on all these considerations, Alternatives 2A would render the outer wall of those double-wall systems (i.e., the existing liner) incapable of being inspected or repaired, making long-term feasibility as a double-wall tank unreliable. This would contradict the whole point of these alternatives. It would also be difficult if not impossible to ensure the long-term performance of this potential option. As a result, this alternative is not considered practicable and is not recommended for implementation at this time. Moreover, this alternative would constitute an irreversible commitment of substantial resources that may be incompatible with the Navy's ongoing evaluation of technologies that will provide new and complete secondary containment by July 15, 2045, as discussed below.

### **3.4 Reasons for Alternative 2B (Composite Tank (Double Wall) Stainless Steel) Not Meeting BAPT**

Alternative 2B differs from Alternative 2A in the type of material used for the new interior lining. Therefore, the reasoning described above for Alternative 2A not meeting BAPT also applies to Alternative 2B.

### **3.5 Reasons for Alternative 3A (Tank within a Tank (Carbon Steel), full Interior and Exterior Coating) Not Meeting BAPT**

As described in the Response to RFI 1, additional evaluation of Alternative 3A from a safety standpoint since publication of the 2019 TUA Decision Document and the 2017 TUA Report has resulted in serious concerns regarding the extremely deep and narrow confined space that the alternative would create between the existing liner and new tank. Space limitations would not only render inspections and repairs problematic, but could also result in serious and unacceptable safety concerns related to potential air supply requirements in the presence of potential harmful vapors. Other unacceptable health and safety concerns related to evacuation time and procedures for workers in the event of liquid entering the "interstitial" space are also a concern. Such concerns could result in Occupational Safety and Health (OSHA) violations. The Navy will not implement a TUA that might submit its workers to life-threatening situations.



Thus, the following attributes argue against selection of Alternative 3A as BAPT:

- **Constructible.** Alternative 3A was initially considered to have somewhat met the criterion; however, the limited available access makes unproven construction techniques at the Red Hill Facility problematic. Access to the Red Hill tanks is limited to an 8-foot-wide opening entering the tank. Materials must be brought inside the tank in smaller sizes, requiring a greater number of welds.
- **Inspectable.** Theoretically, Alternative 3A can be inspected as there is a 5-foot-wide annular space between the interior and exterior walls. However, the ability to have personnel enter a 5-foot-wide annular space for conducting inspections at the bottom of a 250-foot-deep space is nearly impossible (i.e., not practicable) due to the challenges in evacuating harmful vapors to render the workspace safe for personnel entry. The use of supplied air in this type of annular space would be almost impossible. For example, OSHA regulations require a minimum ventilation flow rate of 2,000 cubic feet per minute for each welder in a confined space or personal airline respirators for each worker, such that repair work might not be practicable in such a confined space (29 CFR 1910.252). Moreover, it would not be possible for workers to evacuate the confined space in a timely fashion if dangerous vapor concentrations should occur, such that occupational health and safety requirements may not be achievable. Even in the unlikely event that all the above issues could be addressed, the additional time needed to conduct inspections and space available to implement repairs in this environment would not be practicable. Finally, there are potential safety concerns related to personnel that may be conducting inspections or repairs if hazardous liquids were present in the interstitial space, either from the primary or secondary tank liners, in which case it is not clear how the requirements of OSHA's exit routes and emergency planning requirements could be satisfied (29 CFR 1910, Subpart E).
- **Repairable.** For the same reason that Alternative 3A is not inspectable relative to the outer wall, it would also not be repairable. Finally, the ability to evacuate harmful vapors from this space to render it suitable for "hot work" (e.g., welding steel repair plates) to complete any repairs is also highly questionable.
- **Reliable.** While Alternative 3A is theoretically inspectable and repairable, the practicability and safety issues outlined above call this into question. As such, Alternative 3A would also not be a reliable secondary containment option.

In summary, of the six current TUA Alternatives, only Alternative 1A currently meets the criteria for BAPT. Regarding Alternative 1B, further research and analyses have shown that no commercially available coating can provide a hydraulic barrier, as had originally been hoped, and an interior coating would not provide protection against backside corrosion (i.e., this alternative cannot currently achieve its stated purpose of providing secondary containment). Alternative 1D has multiple issues that relate to structural suitability and long-term reliability. Alternatives 2A, 2B, and 3A are not considered reliable and would also involve an irreversible commitment of resources for potentially unreliable TUA options that would not be compatible with the Navy's commitment for the installation of a true, safe, and reliable new secondary containment system by July 15, 2045.

## 4 Recommended TUA Decision (Alternative 1A)

### 4.1 Brief Description of the Recommended Alternative

Based on the updated TUA evaluation described above, the only alternative that currently meets the requirements for BAPT is Alternative 1A (Restoration of Existing Tank). Therefore, the evaluation of environmental performance focuses on this alternative. However, it is important to recognize that the Navy continues to identify and evaluate new potential technologies that might become additional BAPT alternatives for consideration during future 5-year BAPT re-evaluations. As future TUA decisions are developed, any alternative that meets BAPT will be further evaluated for environmental performance and protection.

Another factor not previously considered that weighs heavily in favor of implementing Alternative 1A is that this alternative is most compatible with accommodating future, reliable, and new double-wall solutions that the Navy is currently evaluating. Implementing Alternative 1A does not irreversibly commit resources and infrastructure that could impede such future implementation, because it is the only alternative that would be completely compatible (relative to key attributes such as inspectability, repairability, reliability, and constructability) with potential future solutions currently being evaluated. Therefore, since Alternative 1A is the only alternative that currently meets BAPT criteria, the environmental performance of this alternative is evaluated in a detailed and holistic fashion regarding prevention, detection, and mitigation, as described below and in Part II of this TUA Supplement.

### 4.2 Holistic Approach to BAPT Decision

#### 4.2.1 **Incorporates All Other Improvements Under the Other Sections of the AOC, Some of Which Have Already Been Implemented**

Alternative 1A consists of three (3) categories of system-of-systems related to environmental protection, including prevention, detection, and mitigation, that are holistically integrated to ensure that the environment and groundwater remain protected. Details related to this summary are provided in the Response to RFIs 1 and 16.

#### 4.2.2 **Alternative 1A Release Prevention Measures Include:**

- **Tank Inspection Repair and Maintenance (TIRM).** The TIRM process begins with draining the fuel, degassing the tank, and cleaning it to achieve conditions suitable for personnel to enter and safely perform inspection and repair work. Qualified non-destructive examination (NDE) technicians perform the tank interior scanning. A comprehensive list of findings and recommended repairs is submitted to the Navy as a Preliminary Condition Assessment Report. Repair design is performed by a licensed professional engineer experienced in storage tank design. After completion of each patch plate or weld repair, each location undergoes NDE evaluation of the repair by a certified inspector who did not perform the welding. In approving the TIRM Decision Document, EPA and DOH agreed that the improved processes will “improve the performance, reliability and integrity” of the existing tanks. As described in more detail in the Response to RFI 3, the Navy is undertaking additional steps

to identify and evaluate potential improvements to the Non-Destructive Examination (NDE) process and fully investigate concerns related to potential risk related to back-side corrosion and other issues. The Navy has developed a detailed *Execution Plan* (DON 2020d) in consultation with the Red Hill AOC Regulatory Agencies to conduct ten categories of investigations, analyses, and planning activities designed to improve the NDE and TIRM processes.

- **Tank Inspection Frequency.** As demonstrated in the Response to RFI 3, the TIRM schedule demonstrates that Alternative 1A can be implemented within the time frame established by the AOC, and if necessary, the inspection can recur in a 20-year interval with prioritization of tanks from the longest time of last inspection.
- **Epoxy Coatings.** Interior coatings do not protect against backside corrosion and do not act as a hydraulic barrier. However, the Navy employs an interior coating to effectively mitigate corrosion cells on those interior surfaces that could otherwise be subject to corrosion and to extend component service life and inspection intervals. The surfaces in the Red Hill tanks that are coated include the lower dome, the interior of the 32-inch nozzles, spot coating (as needed), and the tank extension ring.
- **Small Nozzle Decommissioning.** The *Quantitative Risk and Vulnerability Assessment (QRVA) Phase 1* report (DON 2018c) indicated that although no such releases are known to have occurred, nozzles represented a potential source of risk. The Navy is therefore currently in the process of decommissioning the tanks' small nozzles to significantly reduce the risk of a potential release. (Since the large nozzles can be regularly inspected and repaired, the risk of a release is minimal, and decommissioning those nozzles is not recommended.)
- **Enhanced Contractor Qualifications and Independence.** To limit any potential risk related to human error associated with contractors involved with tank repairs, the Navy has developed a unique prescriptive specification for "Repair of Red Hill Fuel Storage Tanks" (NAVFAC EXWC 2016, Appendix BD).
- **Improved Return to Service Procedures.** Due to the issues related to the 2014 Tank 5 release, the Navy has now revamped tank filling procedures, which were successfully implemented in recent tank refilling operations.
- **Improved Oversight During Clean, Inspect, and Repair (CIR).** Recognizing shortfalls in oversight during the CIR process following the 2014 release from Tank 5, the Navy has since established a dedicated team of professional engineers, contracting officers, construction managers, and engineering technicians to provide better oversight during CIR projects. These new procedures, along with the enhanced contractor qualifications and enhanced operator training, would have prevented the 2014 release from occurring.
- **Revised Standardized Operator Training.** All operators now receive enhanced training that exceeds federal and state regulatory requirements. Elements of this training focus on emergency response and training relative to the sophisticated release detection and inventory monitoring systems.

All these release prevention systems work together to reduce potential risk. They would have prevented the 2014 release; they have successfully prevented any releases from the tanks to the environment since 2014; and they will continue to help ensure that no future releases occur.

#### 4.2.3 Alternative 1A Release Detection Measures Include:

- **Automatic Tank Gauging (ATG) and Automated Fuel Handling Equipment (AFHE).** Highly specialized ATG systems are installed in every tank. The data generated from these systems are integrated into programs that monitor fuel movement and fuel levels in tanks. Various alarms are set to ensure that tanks are not filled above a prescribed height and that minimize the potential for a release. This system is monitored 24 hours a day 365 days of the year. Automatic fuel shut-off levels are also integrated into this system to ensure that a tank will not be overfilled, even in the remote chance that an operator does not manually respond to a high-level alarm. Automated shut-off systems, such as this, are a key component in any fuel storage system that helps ensure overfills are prevented. Finally, the ATG devices are verified using manual tank gauging to help ensure that the devices remain within specifications.
- **Manual Fuel Inventory Trend Analysis.** The Fuels Department leadership conducts a weekly visual trend analysis of ATG data using graphs that cover time periods ranging from several months to more than a year. This analysis allows for continual evaluation of trends to guard against hypothetical releases going undetected.
- **Semiannual Tank Tightness Testing.** State regulations authorize the use of tank tightness testing once per year with a detection level of 0.5 gallons per hour. The Navy currently exceeds the regulatory-mandated time frames for conducting tank tightness testing by conducting testing every 6 months, rather than annually. This testing is based on highly sophisticated instrumentation for mass measurement. The method used by the Navy has been certified by an independent third party known as the National Working Group on Release Detection Evaluations. This group includes release detection experts from ten states and the EPA. As described in the Response to RFI 1, the Red Hill tanks have passed every tightness test conducted since the tank tightness testing program began in 2009.
- **Installing Permanent Release Detection in Each Tank.** The Navy is currently in the process of planning the installation of permanent tank tightness testing equipment in all Red Hill tanks containing fuel, subject to EPA and DOH approval. That upgrade will replace the existing semiannual tank tightness testing program. Permanent installation of this equipment will provide the capability of on-demand tank tightness testing. This will further reduce the likelihood of a minor release going undetected.
- **Soil Vapor Monitoring (SVM).** SVM is another important release detection method used at Red Hill, and part of the layers of protection. Since 2008, the Navy has measured soil vapor concentrations of volatile organic compounds under all the Facility's active fuel storage tanks on at least a monthly basis. Currently, the monthly soil vapor monitoring is conducted using a handheld photoionization detector (PID). In addition, and as described in more detail in the Responses to RFIs 9 and 10, a network of 50 sensors is installed under the 18 active fuel storage tanks (two to three sensors under each tank) (Figure 1). The SVM system is intended primarily to provide a line of evidence for release detection in support of other detection technologies currently in place.

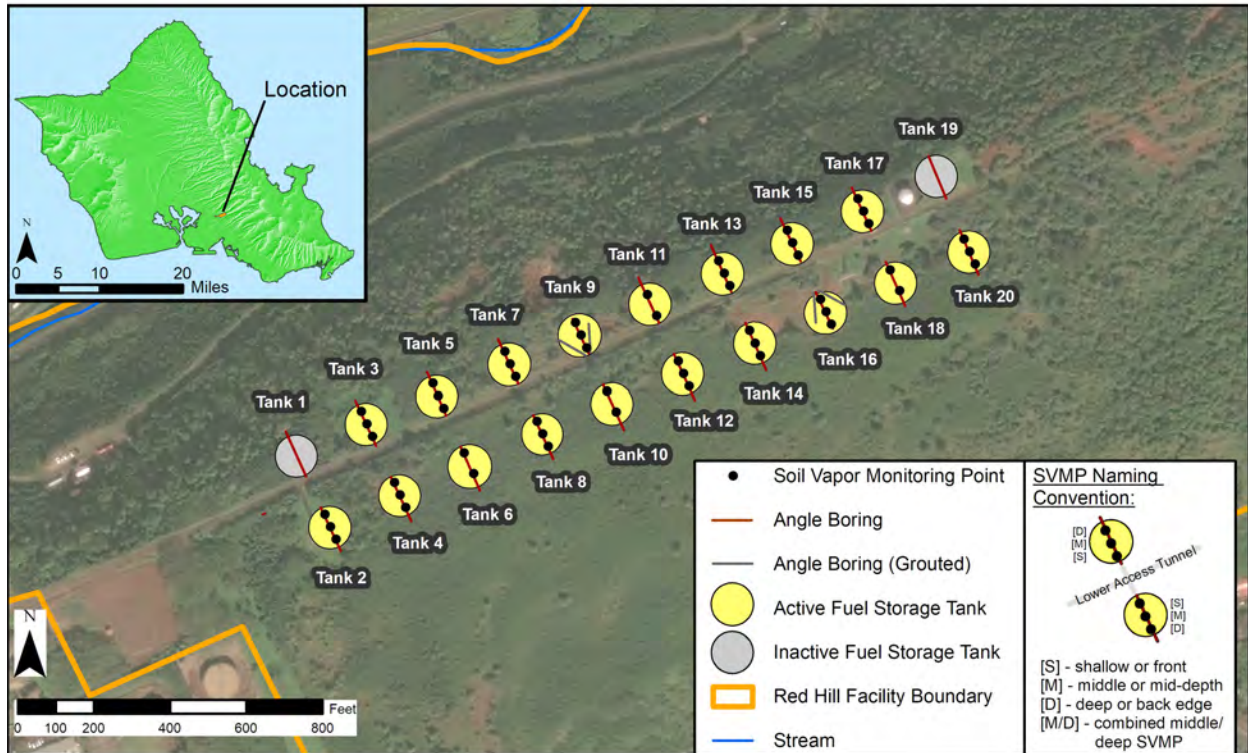

Notes: Soil Vapor Monitoring Program:

- Two to three SVMPs are installed below each active fuel storage tank.
- Every month, the petroleum vapor concentrations are measured at each monitoring point using a photoionization detector (PID), a hand-held instrument commonly used to measure vapor concentrations.
- If measured concentrations increase over time or exceed a defined criterion, the Red Hill Facility operators take additional measures to investigate a possible fuel release.

**Figure 1: Soil Vapor Monitoring Network Underneath the Red Hill Fuel Storage Tanks**

- **Manual Tank and Pipeline Inspections.** Every day, operators inspect tunnel walls, visible portions of tanks, and the pipelines running through the tunnel system to help ensure that any potential release would be identified as soon as possible. This is another backup to the other extensive release detection system-of-systems.
- **Groundwater Long-Term Monitoring.** The Navy established the Red Hill groundwater monitoring network in 2005 with five (5) monitoring locations. The network had expanded to eight locations by the time of the 2014 Tank 5 Release. The Navy has since added an additional 14 single- and multilevel wells for a total of 22 groundwater monitoring locations today, with additional wells being planned and installed as this TUA Supplement is being written. Groundwater monitoring also helps ensure that if a hypothetical release were to otherwise escape detection, it would be detected by the groundwater monitoring network. Extensive data collected during the Red Hill Groundwater Long-Term Monitoring program have confirmed that drinking water has been and remains safe.
- **Drinking Water Monitoring.** In addition to monitoring the groundwater, both the Honolulu Board of Water Supply (BWS) and Naval Facilities Engineering Systems Command (NAVFAC), Hawaii conduct regular drinking water testing and publish annual drinking water

quality reports known as Consumer Confidence Reports. Reports from both BWS and NAVFAC confirm that the drinking water from all area drinking water wells has always and continues to remain safe to drink. As a result of the 2014 Tank 5 release, DOH developed a transition plan to closely monitor the drinking water from the Navy's Red Hill Shaft. Drinking water from the Navy's Red Hill Shaft is now required to be sampled and analyzed at least quarterly. Those reports also verify that the water from Red Hill Shaft is safe to drink.

- **Continuous Soil Vapor Monitoring (CSVM).** In addition to the current release detection methods discussed above, a CSVM sampling and analysis plan is being developed by the Navy in coordination with the AOC Regulatory Agencies as part of a pilot test to determine the efficacy of a site-wide CSVM program. Real-time release detection can reduce the detection time for a hypothetical release from months to days, or even hours. Depending on the results of the CSVM pilot test, real-time release detection should be achievable at full-scale implementation after that capability is integrated into a real-time monitoring network.

The overlapping and integrated release detection systems described above help ensure that any hypothetical future release would be quickly detected and responded to, to minimize potential impacts to the environment.

#### **4.2.4 Alternative 1A-Related Release Mitigation Measures Include:**

- **Emergency Response and Ullage Plans.** The *Red Hill Response Plan* (CNRH 2020), which is included in Part III of this TUA Supplement, outlines necessary critical actions in responding to a release. The release response strategies vary for small, medium, and large release hypothetical response scenarios. The availability of tank ullage has been identified as being important to managing potential risk. Ullage is the space available in other tanks to receive and store fuel if fuel had to be removed from one of the tanks. The Navy revamped its filling procedures in 2020 prior to refilling Tank 5. The Navy now identifies not only the source of the fuel when developing the fill plan, but also which tanks have ullage and could be used to store the fuel in the event of a hypothetical future release.
- **Holding Capacity.** As part of its environmental investigation for the AOC SOW, the Navy analyzed the capacity of the subsurface underneath the Red Hill fuel storage tanks to retain released fuel in naturally occurring lava rock material (basalt) and impede its downward migration to groundwater (DON 2018b, Sections 6 and 9). The analyses considered both hypothetical sudden releases and hypothetical chronic releases and describe a range of naturally retained fuel volumes that may be held within the pore matrix of the basalts that would help reduce/prevent fuel migration to groundwater in the event of a release. If a large enough fuel release were to occur, then the holding capacity might be exceeded, which might result in impacts to groundwater. This information is summarized in the Responses to RFIs 1, 12, 14, and 16 (Part II).
- **Natural Source-Zone Depletion (NSZD).** While the Navy is expending considerable expenses and resources to ensure that hypothetical future releases do not occur, there are important naturally occurring and widely recognized processes that effectively destroy hydrocarbons released into the environment. At Red Hill, a detailed environmental study of NSZD (McHugh et al. 2020) was performed to actually measure the rate at which nature is destroying the fuel released from the Facility some time prior to when groundwater long-term

monitoring began in 2005 (possibly long before 2005). The data indicate that the hydrocarbons are held above the groundwater by the lava rock's holding capacity. While the holding capacity serves to retain potential releases in the pore space above groundwater, NSZD acts to biodegrade the fuel held in the pore space, thus further reducing the risk to groundwater. This information is summarized in more detail in the Responses to RFIs 1, 12, 14, and 16.

- **Monitored Natural Attenuation (MNA).** In addition to the naturally occurring holding capacity and NSZD described above, dissolved fuel constituents that may reach the groundwater are also subject to natural biodegradation that helps mitigate impacts to groundwater. MNA serves to break down dissolved fuel constituents and limit how far they may migrate, stabilizing and limiting any impacts over time. Geochemical and biological studies conducted at Red Hill all indicate the MNA is acting to stabilize fuel constituents in groundwater in the immediate vicinity of the tank farm (i.e., monitoring wells RHMW01, RHMW02, and RHMW03). Additional analyses of groundwater indicate that fuel constituents have not significantly impacted any of the perimeter monitoring wells, the Red Hill Shaft, or any other drinking water wells. This information is summarized in more detail in the Responses to RFIs 1, 12, 14, and 16.
- **Capture Zone/Water Treatment System.** As described in detail in the Response to RFI 16, the Navy is considering the use of a capture zone/water treatment plant as an additional release response and mitigation measure that could be available as a fail-safe protection system in the event of a hypothetical significant future release large enough to impact the drinking water. The capture zone/water treatment system would operate both by establishing a hydraulic capture zone (established by pumping Red Hill Shaft) to limit migration and by treating the drinking water supply, if necessary. Further progress on the design, permitting, funding, and construction of the system may be able to advance once the Navy, DOH, and EPA agree upon both the fundamental aspects of the groundwater model and inclusion of this system as part of the proposed TUA Alternative.

In the event of a hypothetical future release, the release mitigation measures described above would act to minimize the consequences of a release and serve to further protect drinking water resources.

#### **4.2.5 The Recommended TUA Decision is Protective of the Environment and Meets BAPT**

The Navy has developed a bow-tie diagram (Figure 2) that helps visualize how the “system-of-systems” holistically works together to prevent, detect, and mitigate releases with a focus on protecting the environment (especially groundwater). A bow-tie diagram helps to visualize potential risk events (such as a release of fuel) along with potential root causes, consequences, and risk mitigation measures. Use of this tool started in the petroleum industry and is now a widely used tool for risk management in various other fields as well. More details relating to this bow-tie diagram are presented in the Responses to RFIs 1 and 16. All the elements summarized above are included in the bow-tie and are described in detail both within the Response to RFI 1 as well as in all subsequent Responses to RFIs.

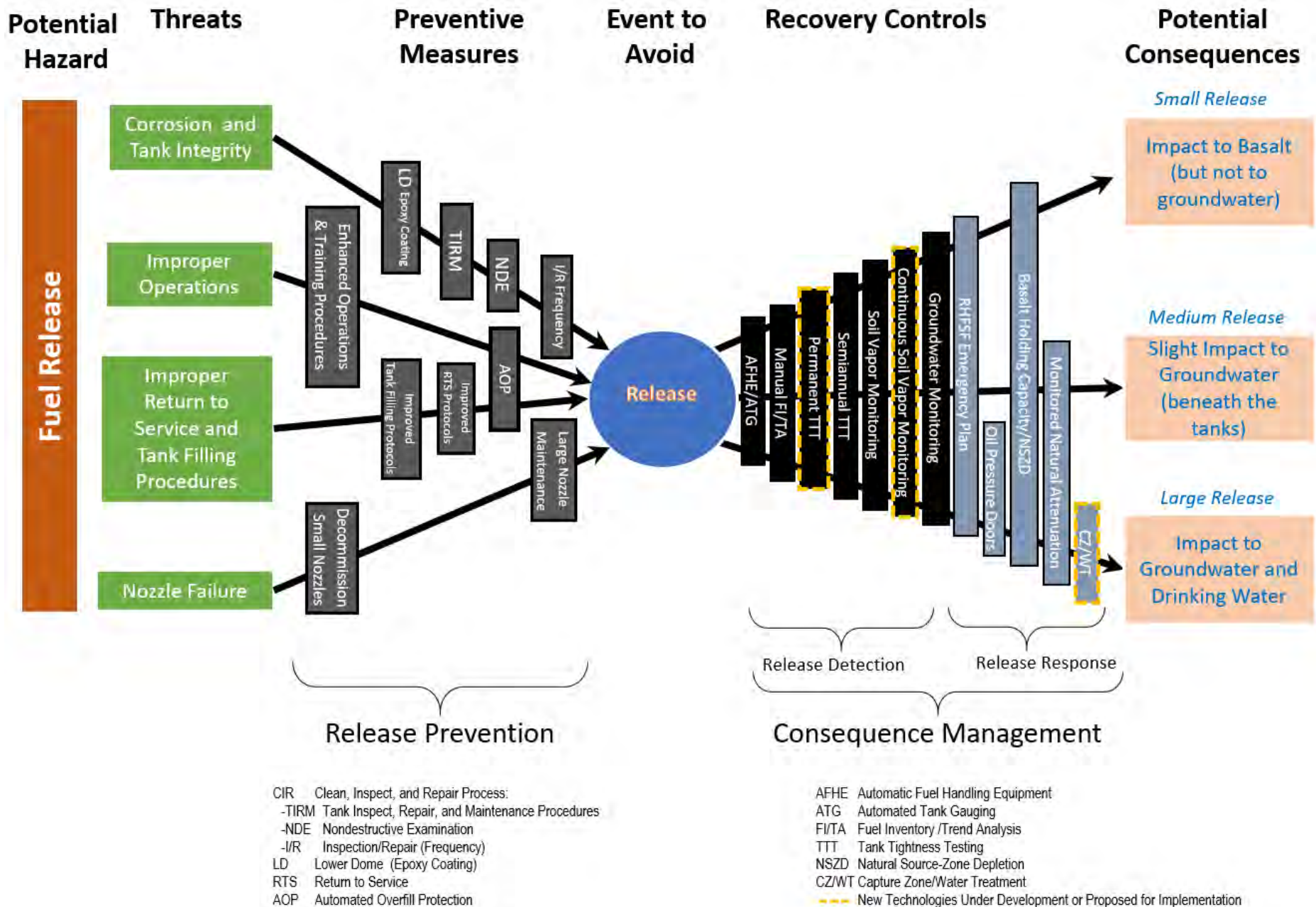

Figure 2: Bow-Tie Diagram for Alternative 1A – Environmental Risk Management



As part of this analysis, potential threats relating to a hypothetical release include corrosion and integrity, improper operations, improper return to service and tank filling procedures, and nozzle failure. Various release prevention barriers are shown on each threat line (on the left side of the bow-tie diagram). This demonstrates the preventive steps that the Navy is taking to help ensure that potential releases do not occur. In addition, release detection and release mitigation barriers are shown on the right side of the bow-tie diagram and cover a range of potential release scenarios, some of which are not known to have ever occurred at the Facility.

The Navy strives for zero releases, and these detection and mitigation measures help to minimize any adverse impacts in the event of a release. Taken together, the combination of release prevention, detection, and mitigation measures, along with the extensive set of available environmental data, demonstrates that groundwater is currently well protected, will remain protected, and that groundwater drinking water is, and will continue to be safeguarded.

## 5 Evolving TUA Process and Addressing Secondary Containment

The AOC recognizes that technological improvements may occur, and new potential TUA alternatives may become available over time. Due to this anticipated evolution of improved options, the currently recommended TUA is the initial BAPT decision, and the Navy has already begun to identify and evaluate potential improved solutions that will lead to implementation of a reliable secondary containment solution once such an alternative becomes available and proves to be practicable.

### 5.1 Repeating 5-Year Review Period

The proposed BAPT implementation schedule assumes a 20-year CIR interval and a 36-month CIR duration for each tank. Figure 3 depicts the proposed schedule for BAPT implementation and displays the assumed timeline for future updated TUA decisions. Each decision is based on an assumed 5-year timeframe which began with the approval of the previous TUA decision. As new TUA alternatives are developed, they may be considered in future TUA decision documents based on their ability to meet BAPT requirements and provide increased environmental protection. During the intervals between TUA decision documents, ongoing research and technology reviews for new products will continue toward ensuring that the best practicable alternatives are considered. While there is a 5-year review applied to BAPT, there would be no intent to wait the full five (5) years if studies showed promise prior to that timeframe, so five (5) years should only be considered the maximum time between BAPT determinations.

This current TUA Decision Document is not the final tank upgrade solution. Rather, it is a step toward achieving secondary containment (as defined by state regulations), which the Navy is committed to completing by July 15, 2045. Future rounds of TUA decisions will not commence until this first decision is reached, based on the TUA documents submitted in 2017 and 2019, and further delays are not recommended.

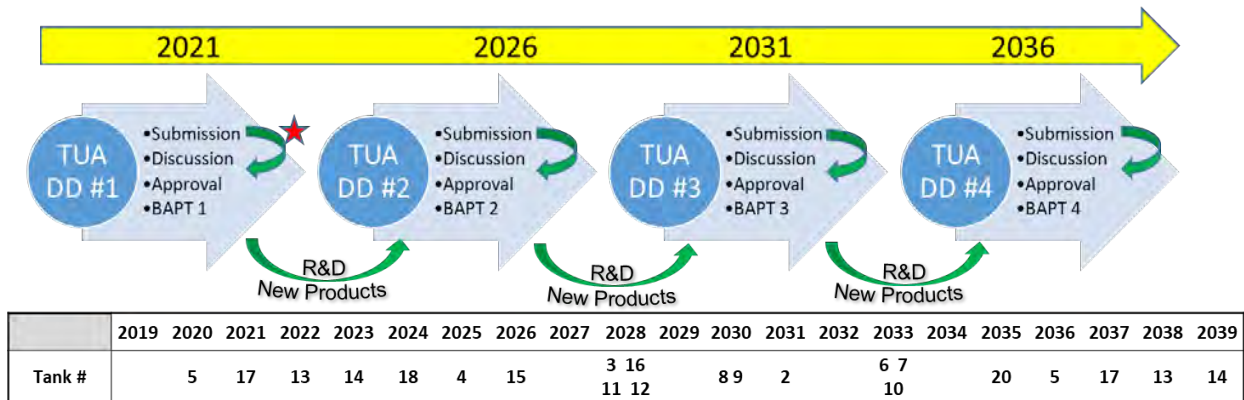

**Figure 3: Proposed BAPT Implementation Schedule as Part of the Clean, Inspect, and Repair Process**

## 5.2 Feasibility Studies and Evaluation of New Technologies

The Navy continues to evaluate research and development opportunities, conduct feasibility studies, and evaluate new technologies toward implementation of secondary containment and associated prevention, detection, and mitigation measures that ensure the environment (with a focus on drinking water) is protected. These efforts will continue after this first TUA Decision is approved and implemented. One key element of the Navy’s ongoing research and development (R&D) efforts is the “Research Partnership with the University of Hawaii at Manoa (UH) College of Engineering and Applied Research Laboratory at UH.” Under this partnership, various engineering, operational, and environmental programs relating to release prevention, detection, and mitigation are underway. A subset of ongoing Navy R&D (including UH) efforts is summarized below.

### 5.2.1 Secondary Containment Feasibility Study

The secondary containment technology that the Navy is currently evaluating is used on tanker ships up to five times the size of the Red Hill fuel tanks. The technology is designed to withstand very harsh environments present during open-ocean transits. The feasibility study is scheduled for completion in 2021, and the results of this effort will be included in the next TUA decision document.

If proven feasible, this solution would not rely on the existing steel liner for either containment or structural support. While investigation of the potential secondary containment solution appears promising, there is currently no practicable way to provide secondary containment measures to the Red Hill fuel tanks in the immediate future until the required studies, designs, and mandatory federal funding processes are completed. Until such time that a new secondary containment alternative is available and practicable, the layers of protection provided by the BAPT outlined in the 2019 TUA Decision Document are the best practicable measures currently available.

### **5.2.2 Continuous Soil Vapor Monitoring (CSVM)**

As previously discussed, a CSVM sampling and analysis plan is being developed by the Navy in coordination with the AOC Regulatory Agencies as part of a pilot test to determine the efficacy of a site-wide CSVM program. Real-time release detection can reduce the detection time for a hypothetical release from months to days, or even hours. Pending the results of the CSVM pilot test, real-time release detection should be achievable at full-scale implementation after that capability is integrated into a real-time monitoring network. As part of this effort, UH is assisting the Navy in evaluation of this technology.

### **5.2.3 Robotic Corrosion Inspection**

Due to the complex and time-consuming nature of corrosion inspection, the Navy is working with UH toward development of a robotic tank inspection technology that may be able to continuously inspect tanks for corrosion, potentially even when they are filled with fuel.

### **5.2.4 Inspect and Repair Protocols**

The Navy has engaged experts at the UH Department of Engineering's Corrosion Laboratory to research how NDE is affected by corrosion products on the steel, develop protocols to measure site-specific corrosion rates, and evaluate repair and patch protocols. The work by UH will be peer-reviewed by an independent corrosion expert. This report will provide information that may be used to update and further improve the NDE and TIRM processes.

### **5.2.5 Element, Phase, and Oxidation Mapping of Red Hill Corrosion by Advanced Microscopy Methods**

The Advanced Electron Microscopy Center at UH will perform element-, phase-, and oxidation-state mapping of coupons extracted from out-of-service Red Hill tanks as well as laboratory-generated corrosion samples. The work by UH will be peer-reviewed by an independent corrosion expert. This report will provide information that may be used to update and improve the TIRM process.

### **5.2.6 Assessment of Microbial Biodegradation**

The Navy is currently working with UH in developing a Microcosm Study and Microbial Parameter Analysis that complements the previous work conducted by the Navy in this area. Microcosm studies are designed to assess the biodegradation potential of naturally occurring microbes in Red Hill basalts under a range of conditions. Microbial parameter analyses are designed to evaluate specific microbes and enzymes that contribute to biodegradation of fuel constituents at Red Hill. These studies will further enhance the Navy's understanding of both NSZD and MNA.

### **5.2.7 Evaluation of Improvements to the NDE Process**

This process will be used to evaluate potential improvements to the NDE process and fully investigate concerns related to potential risk related to back-side corrosion and other issues. The Navy has developed a detailed *Execution Plan* (DON 2020d) in consultation with the AOC Regulatory Agencies to conduct ten categories of investigations, analyses, and planning activities designed to improve the NDE and TIRM processes. Together, these investigations, analyses, and

planning activities will use the collective expertise of local institutions and national subject matter experts to further refine and update the understanding of the condition of the tanks and the processes affecting NDE and corrosion, evaluate potential innovative processes, and ultimately update the NDE and TIRM processes to continually implement the best available and practicable technologies.

### **5.3 Commitment to Secondary Containment by Date Certain**

#### **5.3.1 Justification for the July 15, 2045 Timeframe**

By July 15, 2045, the Navy intends to upgrade all Red Hill tanks with secondary containment, including an inner and outer barrier with an interstitial space that is monitored for releases. If a feasible and reliable secondary containment alternative becomes available and practicable prior to that date, it will be evaluated in a future 5-year TUA decision review cycle and implemented if warranted. However, secondary containment is an additional commitment above and beyond the current BAPT decision recommendation. The Navy remains committed to the AOC and will implement this and future BAPT decisions for all Red Hill fuel tanks by the AOC deadline of 2037.

Regarding its long-term commitment to secondary containment of Red Hill fuel, the Navy intends to fully comply with the technical details of secondary containment, as defined in Hawaii Administrative Rules (HAR) Section 11-280.1-21(c) at the appropriate time. This may or may not correspond to the AOC timeline. The AOC does not necessarily require secondary containment. Thus, in accordance with the AOC, the Navy is requesting Regulatory approval of the recommended TUA decision to carry out the current BAPT upgrades to the Red Hill Facility.

## **6 Addressing Public Comments**

During the TUA and Release Detection Decision Document comment period of September–December 2019, the Regulatory Agencies received and responded to 456 public comments (411 written comments and 45 oral comments).

The majority of the public’s comments were directly related to the following topics:

- 91% - Protection of the aquifer and drinking water
- 76% - Alternate tank locations
- 39% - TUA cost analysis
- 34% - Secondary containment

The Navy appreciates all public input and realizes the importance in remaining steadfast to its commitment of protecting human health, the environment, and Oahu’s drinking water. The public comments related to the topics listed above are addressed throughout this TUA Supplement.

Over \$470M has been allocated by the U.S. Government between now and 2025 to support these upgrade efforts, with additional funding anticipated to support secondary containment. To date, the Navy and DLA have invested over \$219,000,000 in operations, improvements, and environmental investigations at the Red Hill Facility.

Six (6) tank upgrade alternatives were agreed upon between the AOC Parties, and although the Navy did conduct an *Alternative Locations Study* in 2018 (NAVFAC EXWC 2018), an alternative tank location was not one of those agreed-upon alternatives. The Response to RFI 1 (Part II) provides evidence that even if an alternative site had been an agreed-upon TUA alternative, the new location would not be an acceptable BAPT as defined by the AOC.

Detailed tank upgrade alternative cost information that was previously provided in the TUA Decision Document is highlighted again in the Response to RFI 3. Although cost was one of the 18 attributes considered in each of the six (6) tank upgrade options, it was not the main factor in the collective decision-making process. Far more emphasis and importance were placed upon protecting human health, the environment, and Oahu's drinking water.

Approved in September of 2017, the Navy's enhanced CIR program continues to be a proven and successful release prevention methodology. In parallel, the Response to RFI 5 explains the Navy's ongoing commitment to continued upgrades and improvements, and its active engagement in a secondary containment feasibility study with a leading commercial company. It is understood that when a new and proven research or technology becomes available, the Navy will be seeking concurrence and approval from the Regulatory Agencies for implementation. Importantly, as previously described, the Navy is committed to upgrade all Red Hill tanks with secondary containment, including an inner and outer barrier with an interstitial space that is monitored for releases by July 15, 2045.

## 7 Conclusions

The Navy remains steadfast in its commitment to continued safe operations at the Red Hill Facility; ongoing collaboration under the AOC, the best interests of the people of Hawaii, protecting the environment, and ensuring that the water continues to be safe. As part of this overall strategy, no further delays are recommended for implementing the 2019 TUA recommendation. To this end, this TUA Supplement provides additional details, clarity, rationale, and justification for the previous TUA Decision Document with respect to the determination of BAPT, and selection of the current TUA alternative (Alternative 1A). Furthermore, this TUA Supplement describes how the recommended alternative is protective of the environment (with a focus on groundwater and drinking water resources) through use of multiple systems (system-of-systems) that work holistically together to prevent, detect, and respond to potential releases. In addition, the Navy has carefully considered and responded to the public comments to help ensure that the public understands that (1) the drinking water remains safe, (2) the Navy is using the best available and practicable technologies to ensure that the environment remains protected, (3) the Navy continues to identify and drive innovative solutions using the best available minds and resources in Hawaii and elsewhere, and (4) the Navy is committed to the installation of new and reliable secondary containment by July 15, 2045.

The TUA Report (DON 2017a) presented and evaluated the six (6) tank upgrade alternatives (three single-wall and three double-wall/secondarily contained tank options) that can be applied to the tanks at Red Hill to reduce the risk of releases to the environment while maintaining

operational capabilities. This report was approved by the Agencies in a letter dated May 21, 2018 (EPA Region 9 and DOH 2018). The six (6) TUA alternatives are:

- Alternative 1A - Restoration of Existing Tank
- Alternative 1B - Restoration of Existing Tank plus Interior Coating
- Alternative 1D - Remove Existing Steel Liner, Install New Steel Liner with Interior Coating
- Alternative 2A - Composite Tank (Double Wall) Carbon Steel with Interior Coating
- Alternative 2B - Composite Tank (Double Wall) Stainless Steel
- Alternative 3A - Tank within a Tank (Carbon Steel), Full Interior and Exterior Coating

As described in this TUA Supplement, the only alternative that meets BAPT requirements is Alternative 1A. Regarding Alternative 1B, further research and analyses have shown the coating does not provide protection against backside corrosion, and no commercially available coating can provide a hydraulic barrier, as had originally been hoped (i.e., this alternative cannot currently achieve its stated purpose of providing secondary containment). Alternative 1D has multiple issues that relate to long-term reliability. Alternatives 2A, 2B, and 3A are not considered reliable and would also involve an irreversible commitment of resources that is not compatible with and would preclude the Navy's commitment for the installation of true, safe, and reliable secondary containment by July 15, 2045

The proposed BAPT implementation schedule and associated TUA decision documents assumes a 20-year CIR interval and a 36-month CIR duration for each tank. Each progressive decision is based on an assumed 5-year timeframe starting from approval of the previous TUA decision. As new TUA alternatives are developed, they may be considered in future TUA decision documents based on their ability to meet BAPT requirements as well as their ability to provide increased environmental protection. During the intervals between TUA decision documents, ongoing research and technology reviews for new products will continue toward ensuring that the best practicable alternatives are considered. This current TUA Decision Document is not the final tank upgrade solution; rather, it is a step toward secondary containment (as defined by state regulations), which the Navy is committed to completing by July 15, 2045.

The Navy has developed a bow-tie diagram (Figure 1) that helps visualize how the "system-of-systems" holistically works together to prevent, detect, and mitigate releases with a focus on protecting the environment (especially groundwater). A risk bow-tie diagram helps to visualize a risk event (such as a release of fuel) along with its root causes, consequences, and risk mitigation measures. Use of this tool started in the petroleum industry and is now a widely used tool for risk management. More details relating to this bow-tie diagram can be found in the Responses to RFIs 1 and 16. As part of this analysis, potential threats relating to a hypothetical release include corrosion and integrity, improper operations, improper return to service and tank filling procedures, and nozzle failure. Various release prevention barriers are shown on each threat line (on the left side of the bow-tie diagram). This demonstrates the steps that the Navy is taking toward ensuring that potential releases are prevented from occurring. In addition, release detection and release mitigation barriers are shown on the right side of the bow-tie diagram and cover a range of potential release/consequence scenarios. While it is the intent of the Navy to have zero releases, these detection and mitigation measures help to minimize the impact to

groundwater in the event of a release. Taken together, the combination of release prevention, detection, and response measures demonstrates that groundwater is currently well protected, will remain protected, and that the likelihood of an impact to groundwater (and drinking water) is being effectively minimized.

Perhaps the most important consideration in this document is the Navy's commitment to providing secondary containment. By July 15, 2045, the Navy intends to upgrade all Red Hill tanks with secondary containment, including an inner and outer barrier with an interstitial space that is monitored for releases. This is an additional commitment above and beyond the current BAPT decision contained in the 2019 TUA Decision Document. The Navy remains committed to the AOC and will implement that BAPT decision for all Red Hill fuel tanks by the 2037 AOC deadline. Regarding its long-term commitment to secondary containment of Red Hill fuel, the Navy intends to fully comply with the technical details of secondary containment, as defined in HAR Section 11-280.1-21(c), but will be addressing this issue at the appropriate time independent of the AOC, since the AOC does not necessarily require secondary containment. Subsequently, and in accordance with the AOC, the Navy will be requesting Regulatory approval of the 2019 TUA Decision to carry out existing BAPT upgrades to the Red Hill Facility.

Based on the information provided in this TUA Supplement, the Navy has demonstrated that the only current TUA alternative that meets BAPT requirements is Alternative 1A. The measures included within Alternative 1A would have prevented the 2014 release and are completely compatible with the future identification and installation of new secondary containment, unlike the other alternatives currently under consideration. In addition, the Navy has demonstrated how this alternative is protective of the environment, particularly groundwater and drinking water. Therefore, the Navy respectfully requests that the AOC Regulatory Agencies approve the current TUA Decision as a step toward implementing secondary containment in all tanks by July 15, 2045.

This page intentionally left blank



## II Responses to RFIs

This page intentionally left blank

## Response to RFI 1: How the Proposed Tank Upgrade Alternative (TUA) Decision Protects Drinking Water

### **Regulatory Agencies' Comment:**

#### **No Clear Nexus Between Proposed Decision and Protection to Drinking Water Aquifer**

The objective of the Administrative Order on Consent (AOC) is to study the Red Hill facility and its environmental setting to determine the best available practicable technology (BAPT) and practices that should be used at the facility to mitigate risk from potential future releases and provide the best protection to drinking water resources. In the Environmental Protection Agency (EPA) and Hawaii Department of Health (DOH) (Regulatory Agencies) letters dated March 7, 2018 and reiterated in May 16, 2019, we specified that the proposed BAPT must demonstrate that groundwater and drinking water resources are protected. The Navy in the proposed TUA Decision Document has not demonstrated to the Regulatory Agencies that the proposed alternative is the most protective of the groundwater and drinking water resources and other options are either less protective or impractical; and that the proposed alternative adequately mitigates release risk. Evaluations utilizing information gained from other sections of the AOC, such as release detection, groundwater, and risk assessment should be incorporated into the justification.

Instead, page 28 of the Decision Document states, *"In the unlikely scenario of a Significant Release from the Facility, there is a high probability of the Red Hill Shaft being directly impacted within a short period of time. The environmental modeling predicts that for any Significant Release to be captured and prevented from entering the public drinking water source, the Red Hill Shaft would need to maintain continuous pumping, and thus would require a water treatment plant to ensure the quality of the drinking water being supplied to Joint Base Pearl Harbor-Hickam (JBPHH)."* Page 97 of the Decision Document defines Significant (Gradual) Releases as those that occur at rates above 0.5 gallons per hour. The Regulatory Agencies consider the water treatment to be a contingency release response measure and therefore, for the purposes of comparing TUA options, discussion on the related impacts to groundwater and drinking water resources should be provided without this reliance.

### **Navy Summary Response:**

This Response describes the updated process for evaluation of critical attributes for screening the six potential Tank Upgrade Alternatives (TUA) that were established by the AOC Parties relative to BAPT. Based on this updated evaluation, only Alternative 1A currently meets the criteria for BAPT. However, the Navy continues to identify and evaluate potential double-wall secondary containment technologies in the hope that one will satisfy the BAPT criteria in one of the future BAPT re-evaluations, which will re-occur every five (5) years. Moreover, in addition to

implementing BAPT and meeting or exceeding all regulatory criteria, the Navy has committed to upgrading all tanks used for fuel storage with secondary containment by July 15, 2045.

Alternative 1A meets the BAPT criteria. The environmental performance (protection of groundwater) afforded by Alternative 1A was extensively and holistically evaluated to take into account the effectiveness of all the prevention, detection, and mitigation measures described further below, and further detailed in the responses to subsequent Responses to Requests For Information (RFIs) included in this TUA Supplement. Taken together, the combination of prevention, detection, and response measures demonstrate that the groundwater is and will continue to be well protected. A risk bow-tie diagram has been prepared to help visualize hypothetical risks, root causes, potential consequences, and event prevention, detection, and mitigation measures. RFI 1 Figure 1 (at the end of this response) shows the comprehensive layers of protection recommended as BAPT for TUA Alternative 1A. Use of this tool started in the petroleum industry and is now a widely used tool for risk management in a variety of industries.

## **Navy Detailed Response:**

### **1 TUA Alternative Evaluation and BAPT Analysis**

The TUA alternative identification and analysis process for determining the current BAPT for the Red Hill tanks is summarized in this section. Section 2 of this response details the prevention, detection, and mitigation layers of protection (“system-of-systems”) the Navy/Defense Logistics Agency (DLA) is employing at the Red Hill Facility.

AOC Statement of Work (SOW) Section 3 defines the TUA process and BAPT as follows:

*“The purpose of the deliverables to be developed and work to be performed under this Section is to identify and evaluate the various tank upgrade alternatives (“TUA”) and then select and implement the Best Available Practicable Technology (BAPT) and Tank Inspection Repair and Maintenance (TIRM) procedures that can be applied to the in-service tanks at the Facility to prevent releases into the environment.*

*“As used in this SOW, BAPT shall mean the release prevention methods, equipment, repair, maintenance, new construction, and procedures, or any combination thereof, that offers the best available protection to the environment and that is feasible and cost-effective for the Tanks at the Facility. The selection and approval of BAPT shall be based on, but not be limited to, consideration of the following factors: (1) the risks and benefits of the particular technology; (2) the capabilities, feasibility, and requirements of the technology and facilities involved; (3) the anticipated operational life of the technology; and (4) the cost of implementing and maintaining the technology. Reliance on any one of these factors to the exclusion of other factors is inappropriate” (emphasis added).*

During the December 2015 AOC SOW Section 3.0 scoping meetings, the Navy, EPA, and DOH, along with a variety of experts and stakeholders, screened potential tank upgrade alternatives

and selected six (three single-wall and three double-wall/secondarily contained) alternatives for further evaluation.

As described in the AOC SOW Section 3.0 TUA Report (DON 2017a), 18 attributes were identified to facilitate evaluation of the six identified alternatives relative to BAPT. A rating system was also developed to rate the alternatives for the various attributes. For the purposes of this study, an attribute was defined as a quality or feature regarded as a characteristic used to evaluate an alternative's compliance with the criteria. As decided during the Red Hill AOC SOW Section 3.0 scoping meetings and follow-on discussions, the TUA Report did not rank alternatives against each other, but rather, rated alternatives using a non-numerical rating system of attributes that rated the same attribute for each alternative.

The Navy submitted the AOC SOW Section 3.3 TUA Report in December 2017 (DON 2017a) and the Regulatory Agencies approved the report in May 2018. Part D of this report defines each attribute and describes the rating system for each of the alternatives. The attributes included in the analysis are summarized below:

1. **Constructible:** Alternative can be constructed in field at the Red Hill Facility using practicable construction means and methods. Practicable must recognize the difficulty in bringing construction materials into the tanks through the limited-access upper tunnel, or other methods as may be developed for individual alternatives, as well as the degree of difficulty in accessing the tank surfaces for the inspection and repair process.
2. **Testable:** Alternative can be tested and shown acceptable during construction prior to filling and during startup/commissioning when filling.
3. **Inspectable:** Alternative can be inspected to determine integrity on a periodic basis while tank is in or out of service.
4. **Repairable:** Alternative can be repaired in field at the Red Hill Facility using standard traditional construction/repair means and methods.
5. **Practicable:** Alternative can be done or put into practice successfully in the time frame required by the Red Hill AOC SOW given the confines and associated infrastructure of the Red Hill Facility with reasonable expectations that meet stakeholder cost/benefit analysis parameters.
6. **Corrosion Damage Mechanism:** Alternative has a coating system that provides corrosion protection or is constructed of a corrosion resistant material.
7. **Successful Implementation Elsewhere:** Alternative has been put into place at other large fuel depots and is successful in preventing releases to the environment and/or detecting releases.
8. **Reliability:** Ability of alternative to perform is required function (hold product) under stated conditions for a specified minimum period, which is defined as the next out-of-service internal inspection interval.
9. **Impact on Storage Volume:** If the alternative results in a reduction in volume, the reduction is presented as a percent reduction in volume compared to the existing overall Facility volume.
10. **Provides Secondary Containment:** Alternative provides secondary containment of a release from the primary tank. The primary tank is the wall of the tank that provides primary containment, e.g., the wall of a single-wall tank or the inner wall of a double-wall tank.

11. **Dependency on Existing Steel Tank Liner:** Alternative is not dependent on the hydraulic integrity of the existing tank liner to contain product (primary tank) or provide a barrier between a breach of the primary tank, and the environment (i.e., interstitial space boundary, or dike wall/floor secondary containment boundary).
12. **Release Detection Integral to Construction:** Alternative has release detection capability that is integral (i.e., is physically part) of the upgrade construction, such as an interstitial space with monitoring or visible/inspectable space such as a dike surrounding the tank. The complexity and ability to confirm integrity of the system are factored into the rating of the alternative.
13. **Testing and Commissioning Procedures:** Alternative does not require a rigorous level of testing and commissioning procedures to return the tank to service. "Placing the tank in service" refers to actions necessary for the initial filling with fuel, performing commissioning steps and confirming the tank repair process was successful and declared liquid-tight and suitable for transferring custody to the operator for use.
14. **TIRM Requirements for Inspection and Repair of Existing Tank prior to Application of Upgrade:** Alternative requires a level of inspection and repair of existing tank as specified in the AOC SOW Section 2.2 TIRM Procedures Report, Appendix BD: UFGS 33 56 17.00 20-Inspection of Fuel Storage Tanks and Appendix BE: 33 56 18.00 20-Repair of Red Hill Fuel Storage Tanks (NAVFAC EXWC 2016).
15. **TIRM Requirements for Future Integrity Inspections:** Alternative does not require rigorous level of inspection and/or access provisions to complete integrity inspections and tank maintenance.
16. **Impact on Operating and Maintenance Requirements and Procedures:** Current means of filling, emptying, or management of a static tank condition, or tank periodic testing is not impacted by the alternative upgrade.
17. **Tank Upgrade Construction Cost Estimate (Planning Level):** A construction cost estimate of one tank constructed as part of a multi-tank repair contract, excluding government costs, design costs, construction contingencies, inspection costs, and release detection system costs.
18. **Tank Upgrade Duration:** An estimated time to complete one tank upgrade and combinations of tank upgrades including typical government contracting time requirements as compared to the prerequisite timeframe set by the Red Hill AOC SOW (September 28, 2037).

Each attribute was evaluated for all six alternatives. Part E of the TUA Report presents a detailed discussion and ratings of each of the alternatives. Part F of the TUA Report contains a BAPT Tank Upgrade Matrix identifying which of the alternatives met the definition of BAPT. The six alternatives evaluated in the TUA Report (DON 2017a) and the TUA Decision Document (DON 2019c) are:

- Alternative 1A - Restoration of Existing Tank
- Alternative 1B - Restoration of Existing Tank plus Interior Coating
- Alternative 1D - Remove Existing Steel Liner, Install New Steel Liner with Interior Coating
- Alternative 2A - Composite Tank (Double Wall) Carbon Steel, with Interior Coating
- Alternative 2B - Composite Tank (Double Wall) Stainless Steel

- Alternative 3A - Tank Within a Tank (Carbon Steel), Full Interior and Exterior Coating

Each attribute was rated in the following manner:

- Meets Criteria (MC)
- Mostly Meets Criteria (MMC)
- Somewhat Meets Criteria (SMC)
- Mostly Does Not Meet Criteria (MDNMC)
- Does Not Meet Criteria (DNMC)

RFI 1 Table 1 is based on Appendix F-1 BAPT Tank Upgrade Matrix (Table F-1) of the AOC SOW Section 3.3 TUA Report (DON 2017a). The table summarizes the ratings of each attribute for each alternative.

**RFI 1 Table 1: Attribute Ratings for Each TUA Alternative**

#	Attribute	Alternative					
		1A	1B	1D	2A	2B	3A
1	Constructible	MC	MC	MDNMC	SMC	MDNMC	SMC
2	Testable	MC	MC	MC	MC	MC	MC
3	Inspectable	MC	MC	MC	MC	MC	MC
4	Repairable	MC	MC	MC	SMC	SMC	MMC
5	Practicable	MC	MMC	MDNMC	MDNMC	MDNMC	MDNMC
6	Corrosion Damage Mechanism	SMC	MC	MMC	MMC	SMC	MC
7	Successful Implementation Elsewhere	MMC	MMC	MDNMC	MC	MDNMC	MC
8	Reliability	MC	MC	MC	MC	MC	MC
9	Storage Volume Reduction	0%	0%	0%	-12.2%	-12.2%	-20%
10	Provides Secondary Containment	DNMC	DNMC	DNMC	MC	MC	MC
11	Requires Existing Steel Liner Integrity	DNMC	MDNMC	MC	MMC	MMC	MMC
12	Includes Release Detection	DNMC	DNMC	DNMC	SMC	SMC	MMC
13	Testing/ Commissioning Procedures	SMC	SMC	SMC	MMC	MMC	MC
14	Requires Repair of Existing Tanks Prior to Upgrade	MC	MC	DNMC	MMC	MMC	MDNMC
15	Requirements for Future Integrity Inspections	MDNMC	MDNMC	SMC	SMC	SMC	MMC
16	Impact on Operations and Maintenance (O&M) Requirements/ Procedures	MC	MC	MC	MC	MC	MDNMC
17	Tank Upgrade Cost	Exemption (b)(5)					
18	Tank Upgrade Duration	MC	MC	MMC	MMC	MMC	SMC

As in any analysis used to select an alternative, certain primary attributes supersede other attributes. As an example, if an alternative is not constructible, reliable, or capable of achieving its stated purpose, then it is not a viable BAPT alternative, and other factors cannot justify recommending an alternative as BAPT. On the other hand, if evaluation of primary attributes determines that multiple alternatives meet BAPT, then consideration of other attributes become

important secondary considerations for selection of an alternative. Critical screening attributes in recommending BAPT for the Red Hill Tanks include Attribute 1 (Constructible), Attribute 3 (Inspectable), Attribute 4 (Reparable), Attribute 5 (Practicable), and Attribute 8 (Reliable). If an alternative does not satisfy these attributes, it cannot be recommended for implementation as BAPT.

As described in RFI 1 Table 1, the initial evaluation of the alternatives conducted in 2017 concluded that Alternatives 1A and 1B met these critical BAPT criteria. However, information gathered and testing conducted since that time (and since the TUA Decision Document was submitted in 2019) has allowed for additional important considerations regarding several key attributes, as described below. Similarly, Appendix C of the TUA Decision Document outlined various other considerations as part of the Tank Upgrade Alternatives Comparison.

The following discussion provides an updated evaluation of the key factors relative to screening determination of BAPT (in addition to what has already been provided in the TUA Report and the TUA Decision Document):

- **Attribute 1 – Constructible.** Technology that is not currently available cannot be implemented at the present time. In the Regulator-approved TUA Report, only Alternatives 1A and 1B met the criterion of constructible. Alternatives 2A and 3A were considered to have somewhat met the criterion; however, the limited available access makes unproven construction techniques at the Red Hill Facility problematic. Access to the Red Hill tanks is limited to an 8-foot-wide opening entering the tank. Materials must be brought inside the tank in smaller sizes, requiring a greater number of welds. This greater number of welds increases the likelihood of a weld failure (a reliability issue) that could result in a release. Alternatives 1D and 2B were considered to have not met the criterion because they had not been successfully used at any other facility. Implementing Alternative 1D would require forcibly removing the existing liner plates from the backing, including concrete and metal support structures, which would risk structural damage and call into question the long-term reliability of the overall system. Under Alternative 1B, the interior of the tank cannot be fully coated due to the interior surface area and the cure time for the coating. Additional analyses by the Navy indicated that the coating process would also require an additional 18 months to complete for each tank, if it could be done at all, which might not be achievable within the AOC implementation timeframe.
- **Attribute 5 – Practicable.** This attribute rates whether the technology is practicable (note the difference between “practicable”, i.e., feasible to implement, and “practical”, i.e., useful). An alternative is practicable only if it is capable of reasonably being implemented. Only Alternatives 1A and 1B were initially rated as meeting or mostly meeting the criterion. However, due to the issues discussed relative to coating an entire tank (also see Reliability attribute) in a timely manner, Alternative 1B is deemed not practicable.
- **Attribute 3 – Inspectable.** This alternative considers the capability of each alternative to be inspected. Single-wall Alternatives 1A, 1B, and 1D can all be inspected. However, the exterior wall of the double-wall Alternatives 2A and 2B cannot be inspected or repaired once the second wall is constructed inside the tank and concrete is used to fill the space between the layers. This in turn impacts longer-term reliability and reparability, prevents the use of the



AOC-approved TIRM process on the outer wall, and is incompatible with the Navy's position to have secondary containment by July 15, 2045. Theoretically, Alternative 3A can also be inspected as there is a 5-foot-wide annular space between the interior and exterior walls. However, the ability to have personnel enter a 5-foot-wide annular space for conducting inspections at the bottom of a 250-foot-deep, 5-foot-wide space is nearly impossible (i.e., not practicable) due to the challenges in evacuating harmful vapors to render the workspace safe for personnel entry. The use of supplied air in this type of annular space would be almost impossible. For example, Occupational Safety and Health Administration (OSHA) regulations require a minimum ventilation flow rate of 2,000 cubic feet per minute for each welder in a confined space or personal airline respirators for each worker, such that repair work might not be practicable in such a confined space (29 CFR 1910.252). Moreover, it would not be possible for workers to evacuate the confined space in a timely fashion if dangerous vapor concentrations should occur, such that occupational health and safety requirements may not be achievable. Even in the unlikely event that all the above issues could be addressed, the additional time needed to conduct inspections and space available to implement repairs in this environment would not be practicable. Finally, there are potential safety concerns related to personnel that may be conducting inspections or repairs if hazardous liquids were present in the interstitial space, either from the primary or secondary tank liners, in which case it is not clear how the requirements of OSHA's exit routes and emergency planning requirements could be satisfied (29 CFR 1910, Subpart E).

- **Attribute 4 – Repairable.** As described in Attribute 3, the outer wall of the double-wall tank options in Alternatives 2A and 2B are not repairable. For the same reason that Alternative 3A is not inspectable relative to the outer wall, it would also not be repairable. Finally, the ability to evacuate harmful vapors from this space to render it suitable for hot work to complete any repairs is also highly questionable.
- **Attribute 8 – Reliable.** Alternative 1D presents several reliability concerns. It could provide a new corrosion mechanism by introducing new material in contact with the existing concrete. Furthermore, the extent that the steel plates were attached to the concrete was previously underestimated. After removing coupons from Tank 14 for the AOC SOW Section 5.3.3 *Destructive Testing Results Report* (DON 2019b), and during actual repair work, the feasibility of Alternative 1D was found to be much more challenging than originally anticipated because many areas of the liner are in intimate contact with the underlying concrete and steel. Forcible detachment of the liner from the underlying concrete and steel could weaken the overall structure. Alternatives 2A and 2B would render the outer wall of those double-wall systems (i.e., the existing liner) incapable of being inspected or repaired, making long-term feasibility as a double-wall tank unreliable, which would contradict the whole point of these alternatives. While Alternative 3A is theoretically inspectable and repairable, the practicability and safety issues outlined above call this into question. As such, Alternative 3A would also not be a reliable secondary containment option. Alternatives 2A, 2B, and 3C would also involve an irreversible commitment of resources that is not compatible with and would preclude the Navy's commitment for the installation of true, safe, and reliable secondary containment by July 15, 2045. Regarding Alternative 1B, further research and analyses have shown the coating does not provide protection against backside corrosion, and no commercially available

coating can provide a hydraulic barrier, as had originally been hoped (i.e., this alternative cannot currently achieve its stated purpose of providing secondary containment).

The ratings for the other attributes are briefly summarized as follows:

- **Attributes 2 and 8** were rated as meeting criteria for every alternative.
- **Attributes 4, 6, 13, and 16** had no significant differences across all alternatives.
- **Attribute 9** is also an important consideration because reduction in storage capacity at the Red Hill Facility could impact the entire purpose of the Facility in providing a strategic fuel reserve for U.S. military forces in the Indo-Pacific region. It would therefore impede the Red Hill Facility from meeting mission requirements to store fuel as required by the Department of Defense's U.S. Indo-Pacific Command.
- **Attributes 10, 11, 12, 14, and 15** do not favor single-wall containment. However, the Regulator-approved AOC SOW Section 2.4 TIRM Decision Document (NAVFAC EXWC 2017) reduces risk of a release and helps offset these attributes. The installation of permanent tank tightness testing equipment that is proposed under Alternative 1A will significantly improve the ability to identify, prevent, minimize, and respond to any hypothetical release. In addition, all the other technologies and procedures being implemented by the Navy related to release prevention and detection, which are detailed throughout this Supplement to the TUA Decision Document, provide a holistic means of groundwater protection.
- **Attribute 17** for cost was included for comparison purposes. Opponents of Red Hill have unfairly argued that "the Navy has simply chosen the cheapest option." That is untrue as cost is not the driving consideration, rather the ability to meet BAPT requirements is the primary driver. In accordance with the AOC, however, cost may be considered, and should be as the Navy is required to be a good steward of taxpayer dollars. For example, the construction of a new aboveground storage facility that would completely replace the existing tank system (which would not fall under the AOC definition of BAPT for the existing tanks and which was not identified during TUA scoping as one of the six TUA alternatives) is anticipated to be over ten times the cost of the proposed BAPT and would not be able to be constructed by the 2037 AOC deadline. Furthermore, opponents of Red Hill are just as likely to similarly oppose the construction of any large fuel tanks at any alternative location on the island. Above ground storage tanks containing our nation's strategic military fuel reserve would also be more vulnerable to attack in times of conflict.

Seismic resistance and protection from kinetic attack were not evaluated as attributes in the TUA Report. The Red Hill Facility was designed and constructed to resist kinetic attack. EPA's independent consultant PEMY evaluated catastrophic release potential at the Red Hill Facility in September 2015 and concluded the Facility had a very low potential for a catastrophic release and was well-protected from geologic and natural hazards (PEMY Consulting 2015), and the Navy's experts agree with this assessment. Seismic resistance was not selected as one of the agreed-upon TUA attributes and therefore was not included in the TUA Decision Document (DON 2019c). Nevertheless, future work described in the AOC SOW Section 8.2 *Risk/Vulnerability Assessment Phase 2 Scope of Work* will include a seismic evaluation (DON 2020e).

Since the *Alternative Location Study* (NAVFAC EXWC 2018) was not part of the identified and agreed-upon TUA alternatives, it is not considered in the evaluation. Moreover, closing down all the existing tanks and constructing an entirely new tank farm does not fall under the AOC definition of BAPT as technologies that “can be applied to the in-service tanks at the Facility to prevent releases” or “is feasible and cost-effective for the Tanks at the Facility” (emphases added). Many of the potential alternative locations were rated as not meeting the criterion because of the inability to construct a pipeline to convey fuel to Pearl Harbor from an alternative location due to environmental and other restrictions. In addition, the best alternative location identified in the *Alternative Location Study* was a new facility constructed adjacent to the Red Hill Facility to allow use of the existing pipeline. However, the location identified in the study is still located above the drinking water aquifer. For these reasons and more, the Navy is currently pursuing an upgrade to the existing Red Hill Facility using an approved BAPT in accordance with the AOC.

Based on the refined evaluation described above, it is clear that currently the only alternative that currently meets the requirements for BAPT is Alternative 1A. Therefore, the evaluation of environmental performance is currently limited to this alternative. However, it is important to recognize that the Navy continues to identify and evaluate new potential technologies that might become additional BAPT alternatives for consideration during future 5-year BAPT re-evaluations. As future TUA decisions are developed, any alternative that meets BAPT will be further evaluated for environmental performance/protection.

Relatedly, another factor not previously considered that weighs heavily in favor of implementing Alternative 1A at the current time is that 1A is the current alternative that is most compatible with accommodating future, reliable, and new double-wall solutions that the Navy is currently evaluating. Implementing Alternative 1A does not irreversibly commit resources and infrastructure that could impede such future implementation, because it is the only alternative that would be completely compatible with potential future solutions that are currently being evaluated. Therefore, since Alternative 1A is the only alternative that currently meet BAPT criteria, the environmental performance of this alternative is evaluated in a detailed and holistic fashion with regard to prevention, detection, and mitigation as, described below in Section 2 and subsequent Responses to RFIs.

## **2 Alternative 1A Mitigates Risk from Hypothetical Future Releases and Will Continue to Protect Drinking Water Resources.**

This section describes how Alternative 1A, which incorporates all the layers of protection (including prevention, detection, and mitigation measures) currently in place and being continually improved upon through the AOC process, mitigates the potential for releases and protects the drinking water resource. The following sections describe the relationship between the various systems related to release prevention, release detection, and release response, and how they holistically work together to protect groundwater and the environment. These measures are graphically illustrated in the bow-tie diagram presented and discussed below in Section 3 of this response. The following subsections describe each of these elements and subsequent responses to RFIs describe them in more detail, as well as describing their interrelationships.

## 2.1 Prevention

As described in the following, Alternative 1A includes eight different preventative measures that address the primary identified contributors to potential risk as identified in the AOC SOW Section 8 *Quantitative Risk and Vulnerability Assessment Phase 1* report (DON 2018c).

### 2.1.1 TANK INSPECTION REPAIR AND MAINTENANCE (TIRM)

The Tank Inspection Repair and Maintenance (TIRM) process, which implements inspection and repair standards adapted from American Petroleum Institute (API) Standard 653 “Tank Inspection, Repair, Alteration, and Reconstruction” (API 2014), is a key element in preventing any releases to the environment. The AOC SOW Section 2.2 TIRM Report (NAVFAC EXWC 2016) defined the processes of inspection, repair, and maintenance of the Red Hill Facility designed to ensure the integrity of the tanks. The AOC SOW Section 2.4 TIRM Decision Document was submitted in April 2017 (NAVFAC EXWC 2017) and approved by the AOC Regulatory Agencies in September 2017 (EPA Region 9 and DOH 2017).

In summary, the TIRM process begins with draining the fuel, degassing the tank, and cleaning it to achieve conditions suitable for personnel to enter and safely perform repair work. An independent API 653-certified inspector visually inspects the tank to assess the condition and integrity. The next step involves a highly detailed inspection of the entire interior surface of the tank.

Qualified non-destructive examination (NDE) technicians perform the tank interior scanning. Before being allowed to perform inspections inside the tank, each NDE technician must successfully pass a blind test on site to confirm they can identify defects on both coated and uncoated plates. The results of these evaluations are documented and kept on file. The thickness of the steel plates is manually scanned in an overlapping pattern using Low Frequency Electromagnetic Technique (LFET) instruments. Ultrasonic Technique (UT) is used to back up indications resulting from the LFET inspection. Balanced Field Electromagnetic Technique (BFET) is used to scan the condition of the welds joining the steel plates. Ultrasonic Shear Wave Technique is then used to measure the depth of detected weld indications. Independent “prove-up” inspections are followed up by the API 653 certified inspector using Phased Array Ultrasonic Testing (PAUT) equipment. The API 653 inspector identifies areas requiring repair. At the sites requiring repair, the PAUT prove-up scan is used to further measure the steel liner thickness beyond the repair locations so that steel patch plates can be properly sized to ensure that the plates are lap-welded to original steel liner with adequate thickness.

The API 653-certified inspector also conducts a second visual inspection of the entire tank interior. API 653 inspectors have stated they can usually visually identify 90% of the defects. Typically, less than 2% of the interior surface area of the tank requires repair with patch plates.

A comprehensive list of findings and recommended repairs is submitted to the Navy as a Preliminary Condition Assessment Report. The Navy/DLA review and approve this report and the list is published as the Tank Repair Recommendations. Approval of these recommendations by the Navy/DLA forms the basis for funding and authorization for the contractor to perform repairs.

Repair design is performed by a licensed professional engineer experienced in storage tank design. Locations requiring patch plates are evaluated for distance to existing weld seams and spacing relative to adjacent repairs. Patch plate dimensions and shapes are designed for each repair location. The patch plate is serialized to confirm it is installed in the proper location. Locations requiring weld joint repairs are ground out and independently inspected for proper preparation prior to performing the weld repair.

After completion of each patch plate or weld repair, each location undergoes NDE evaluation of the repair by a certified inspector who did not perform the welding. These tests include visual inspection, magnetic particle inspection, and vacuum box inspection. The dates and initials of personnel completing repairs and inspections are recorded at each repair location inside the tank and documented so accountability can be maintained. An initial final inspection is performed by API 653-certified inspectors before a second inspection is completed by a senior Navy engineer to verify repairs were adequately completed and documented. The contractor's Tank Engineer and API 653 inspector issue a Suitability for Service Testament that the tank is satisfactory for service. Finally, the Commanding Officer of Naval Facilities Engineering Systems Command (NAVFAC), Hawaii, a Navy Civil Engineer Corps Captain who is also a licensed professional engineer, certifies the construction is complete on each Red Hill tank before it can be filled.

Due to the inspection technology employed and the additional quality control procedures, the cost for the current TIRM process at the Red Hill Facility is much more than in past years. Prior to the signing of the AOC in 2015, the Navy/DLA spent in the range of \$5–6 million per tank. Since 2015, cleaning, inspection, and repair of a Red Hill tank can approach almost \$30 million per tank.

As described in the Response to RFI 3, the Navy has developed and is implementing an *Execution Plan* for AOC SOW Section 5.4 to address potential limitations of the NDE process and regulatory concerns related to corrosion. The Navy is continuing to research better ways of identifying every location requiring repair during the TIRM process.<sup>1</sup> This is occurring despite only two percent of the total surface area typically requiring repair, and the low risk associated with missing a repair area. The thinnest section of steel liner identified in Tank 14 in the *Destructive Testing Results Report* (DON 2019b) was still nearly half the thickness of the original steel liner. This ongoing effort is being pursued through the work identified for AOC SOW Section 5.4.

The purpose of AOC SOW Section 5.4 is to improve the current inspection process as identified in the AOC SOW Section 2.4 TIRM Decision Document (NAVFAC EXWC 2017). The agreed-upon goal between the AOC Regulatory Agencies and the Navy/DLA for an improved TIRM process is to prevent any release during the service interval between Clean, Inspect, and Repair (CIR) cycles. Improvements will focus on significant and practicable opportunities to increase confidence in achieving TIRM performance goals.

<sup>1</sup> Note that since before the AOC introduced the acronym "TIRM", the Navy referred to its clean, inspect, and repair process using the acronym "CIR". The two acronyms are essentially interchangeable for purposes of this document.

The AOC *Section 5.4 Execution Plan* (DON 2020d) outlines the documents the Navy/DLA will prepare to respond to AOC Regulatory Agency comments regarding previous work and deliverables under AOC SOW Section 5.3. The Navy will provide documents consisting of additional research, studies, data, information, investigations, and recommendations. The intent of these documents is to clarify, explain, amplify, and present new information both in furtherance of responses related to AOC SOW Section 5.3, as well as implementation of AOC SOW Section 5.4. The *Execution Plan* is currently under review by the AOC Regulatory Agencies.

Some of the practices being used by the Navy to improve the TIRM process are described below; additional considerations are addressed in the Response to RFI 3.

#### 2.1.2 TANK INSPECTION FREQUENCY

RFI 3 Table 1 shows the proposed CIR schedule, which demonstrates that the CIR process can be completed within a 20-year recurrence interval in accordance with API 653. Following 2014, the Navy improved the CIR process to include greater quality assurance. These improvements require significantly more time and effort during the CIR process. The Navy successfully returned Tank 5 to service in 2020 using those enhanced procedures. Additionally, the Navy is now on schedule to similarly upgrade and return one tank each year to service. Finally, the Navy has re-prioritized the CIR schedule to ensure that the tanks with the longest time between inspections are now prioritized in the CIR process.

#### 2.1.3 EPOXY COATING

Interior coatings do not protect against backside corrosion and do not act as a hydraulic barrier. However, the Navy employs an interior coating to effectively mitigate corrosion cells on those interior surfaces that could otherwise be subject to corrosion and to extend component service life and inspection intervals. The surfaces in the Red Hill tanks that are coated include the lower dome up to 36 inches above the joint connecting to the barrel, the interior of the 32-inch nozzle, spot coating, as needed, and the tank extension ring including extending 6 inches above and 6 inches below the extension ring. (The extension ring is the area between the barrel and the upper dome that was initially installed to allow for potential expansion and contraction. However, no movement has ever been noted between the barrel and the upper dome.) The lower dome and nozzle are coated because water separates from the fuel on the bottom and in the nozzle. By contrast, the inside surfaces of the tank that are in contact with fuel, such as the barrels, are inherently protected from corrosion. The coating is a barrier between the water and the steel liner that prevents internal corrosion from occurring. The tank extension ring is susceptible to corrosion from condensation that occurs due to temperature differences between the fuel and the atmosphere. The coating prevents internal corrosion in this area. These coatings have a proven track record of lasting longer than the 20-year intervals between maintenance cycles.

The interior epoxy coating system used in Red Hill tanks meets the requirements of Unified Facilities Guide Specification [UFGS] 09 97 13.15. The coatings in use are highly cross-linked, providing better chemical/fuel resistance than standard epoxy coating products, and exhibit high impact resistance and flexibility beyond conventional tank coatings. The UFGS specification includes robust quality control and quality assurance requirements for the epoxy coating

application, as well as contractor oversight. The dry film thickness is 24–30 mils. The coating system is expected to exceed 50 years without any failure.

#### 2.1.4 SMALL NOZZLE DECOMMISSIONING

Phase 1 of the AOC SOW Section 8 *Quantitative Risk and Vulnerability Assessment (QRVA)* (DON 2018c) indicates that if an issue were to develop with one of the tank nozzles, there is potential risk of a release from the tank. There are two types of nozzles, large and small. As to the small nozzles, the Navy is addressing the potential risk by reconfiguring the nozzle piping to decommission each small nozzle and convert it into a carrier pipe (e.g., secondary containment) for fuel sample lines. This change is performed when each tank undergoes the CIR process. The small nozzle for Tank 5 has already been decommissioned. The small nozzles for Tanks 13 and 14 are currently being decommissioned and converted to carrier pipes as part of the TIRM process. In addition, Tanks 17, 18, and 20 do not have the smaller nozzles, so there is no risk from such a release at these tanks. With the decommissioning of the smaller nozzles, the Navy has ensured that nozzles can be physically inspected and repaired by a human being to provide improved quality assurance.

As to the large nozzles, it is unlikely that a hole would develop in the large nozzle unless there is a catastrophic event, such as impact from a large object. However, this is extremely unlikely, as the nozzles are located in the overhead space in a relatively small area that a large object would not be able to fit into. The section of nozzle piping located outside the limits of the concrete foundation is typically no more than 30 inches in length and is therefore highly unlikely to be impacted. Moreover, if an impact were to occur in this area, inspectors would be able to detect any such issues and any hypothetical release would be to the tunnel rather than directly to the environment.

#### 2.1.5 ENHANCED CONTRACTOR QUALIFICATIONS AND INDEPENDENCE

To limit any potential risk related to human error associated with contractors involved with tank repairs, the Navy has developed a unique prescriptive specification for “Repair of Red Hill Fuel Storage Tanks” (Specification Section 33 56 20.00 20). In addition to the NAVFAC Design-Build General Requirements for contractor management and supervision, the prescriptive specification expressly identifies project roles for contractor positions. The roles include the designer of record, tank engineer, tank inspector of record, marine chemist, welder, welding operator, and NDE examiner. Certifications, qualifications, and experience requirements are specified and listed as submittals requiring Government approval.

The prescriptive specification states that the NDE examiners and the weld inspectors may not represent nor be an employee of the prime contractor or the welding subcontractor. Should an NDE examiner or weld inspector also be a welder, that individual is disqualified from inspecting or examining a weld of their own work. If any welders make defective welds, they will be removed from the work site by the Quality Control Manager and a new welder would complete the weld.

#### 2.1.6 IMPROVED RETURN TO SERVICE PROCEDURES

One of the other categories of potential risk is the procedure to return a tank to service, for example after the TIRM process is completed in a tank (DON 2018c). The Navy therefore

significantly revamped its filling procedures in 2020 prior to refilling Tank 5. These procedures are now included in the revised specifications and are required whenever a Red Hill tank is refilled following completion of the TIRM process (Specification Section 33 56 20.00 20).

Under the new procedures, the Navy conducted tank tightness tests at four stages in the 2020 Tank 5 refilling process, all of which confirmed that the tank was tight. Prior to this, tank tightness testing was not conducted during the initial filling process after returning a tank to service. Also, in between tank tightness tests, there are now an additional six holding points at various fill levels throughout the filling process. This provides the Control Room Operator and other operations personnel a better opportunity to monitor the tank and confirm there are no releases. This procedure would also minimize a release in the event that one should occur during the process. In addition, authorization from senior leadership is now required prior to the refilling of a tank. Concurrently, the Navy now conducts soil vapor monitoring (SVM) during these tank tightness tests as a secondary means of verifying the integrity of the tank.

#### 2.1.7 IMPROVED OVERSIGHT DURING CIR

Recognizing shortfalls in oversight during the TIRM process following the release from Tank 5, the Navy has since established a dedicated team of professional engineers, contracting officers, construction managers, and engineering technicians to provide better oversight during CIR projects. The contractor is required to provide third-party oversight of areas of work with an independent first tier subcontractor (including Society for Protective Coatings SSPC QP 5, Marine Chemist, SSPC Protective Coatings Specialist, hazardous materials abatement clearance [PQP], NDE technician [ASNT Level II], API 653 tank inspector, Certified Industrial Hygienist, and testing laboratory [A2LA]). The Navy also uses an independent technical services contractor to perform quality assurance of tank repair activities (welding and mechanical repairs, NDE work, and review of welding and NDE documentation).

#### 2.1.8 REVISED AND STANDARDIZED OPERATOR TRAINING

The Red Hill Facility must comply with the Federal Energy Policy Act of 2005. This requires each state receiving Resource Conservation and Recovery Act (RCRA) Subtitle I funding to develop state-specific operator training requirements. Class A, B, and C Operators must complete initial training, within 30 days, upon arriving and beginning work at a facility with underground storage tanks (USTs). A Class A Operator is a person with primary responsibility for the operation, maintenance, and compliance of the UST system. A Class B Operator is a person who has responsibility for day-to-day implementation of regulatory requirements. A Class C Operator is a person who is the first line of defense in emergency response conditions of the UST system. Emergency response includes, but is not limited to, spills and responses from UST systems. Class A and B Operators are recertified every 5 years. Class C Operators are retrained and recertified annually. All operators receive certificates upon validation of the required training. The Oil Pollution Act of 1990 mandates Annual Oil Spill Response Training. All operators at the Red Hill Facility attend annual training and receive Oil Spill Response Training Certification. In addition, all control room operators receive annual refresher training on the Automated Fuel Handling Equipment (AFHE). This ensures that operators are receiving sufficient training proficiency to operate the Facility in routine, non-routine, and emergency situations.



After reviewing training records in 2017, an independent regulatory evaluation by a team of subject matter experts, hired by EPA and working in conjunction with EPA and DOH, determined the Navy has a training program in place that meets the requirements of the UST regulations applicable to the Red Hill Facility (Atlas et al. 2017). The independent evaluation team reviewed training records for the past 3 years, provided by the Navy's training supervisor. The Deputy Fuel Director noted that operators cannot advance to the position of Control Room Operator until they acquire a specific amount of experience in the operations group (e.g., as a "rover"). Certificates documenting completion of training are provided to DOH as training is completed. The regulatory evaluation team briefly reviewed the slides provided during the training and verified that the curriculum was appropriate for the different classes of UST operators. The regulatory evaluation team also reviewed the matrix that tracks site-specific training and noted that it covers the work areas relevant to UST system operation. The regulatory evaluation team was able to verify training records for the individuals with whom the regulatory evaluation team interacted during the evaluation.

#### 2.1.9 COMMITMENT TO SECONDARY CONTAINMENT

The Navy intends to upgrade all Red Hill tanks with secondary containment by July 15, 2045. The Navy is currently conducting a feasibility study to evaluate a promising technology that may be capable in the future of meeting the detailed requirements for secondary containment in the Hawaii UST regulations. Notably, should this technology prove feasible, it would provide true secondary containment using two new layers, and it is more compatible with implementing Alternative 1A, the current BAPT, than with any other alternative currently being considered.

This is an additional commitment over and above the current BAPT (and also exceeds the requirements of applicable UST regulations). This does not change the fact that the Navy is committed to the AOC and will implement each successive BAPT decision on all tanks by the AOC deadline. If a practicable secondary containment solution is not available by July 15, 2045, fuel will be removed from the tanks by that time. The Navy/DLA will determine the expected service life of the Red Hill Facility and will evaluate alternate bulk fuel storage options. A plan for placing the empty tanks in a strategic ready reserve status will also be developed in the event of wartime requirements that the Navy must adhere to.

## 2.2 Detection

As described below, Alternative 1A includes eight different release detection measures that have either already been implemented or are recommended for implementation or further study. As described in more detail in the Responses to RFIs 6, 7, and 8, this system of release detection systems will continue to provide layers of protection and will be improved upon over time.

#### 2.2.1 AUTOMATED FUEL HANDLING EQUIPMENT (AFHE)

In 2001, the Navy installed Automatic Tank Gauging (ATG) equipment on all 18 serviceable USTs at the Red Hill Facility. Currently, the ATG equipment measures temperature and pressure and acts as the fluid-level measuring module for the overall AFHE control system at the Red Hill Facility. In the current configuration, the ATG system works in conjunction with the AFHE system to perform inventory management.

The ATG system employed is described as a hybrid tank gauging system that combines traditional and hydrostatic tank gauging qualities, measuring both mass and density. Mass is measured because volume can change with temperature, whereas mass remains constant unless fuel is moved into or out of a tank. Each tank at the Red Hill Facility is fitted with a vertical array of temperature and pressure sensors that provide the data. The system records temperature and pressure from the sensors in ATG-mode, and the software converts these readings to the data used in the tank level module of the AFHE system.

In its current configuration, the ATG system provides data to the tank level module of the AFHE system. The AFHE is an inventory control system used to track the product inventory in the overall Facility in real-time. The AFHE system is monitored 24 hours a day, 7 days per week, throughout the year. The ATG equipment installed in the USTs at the Red Hill Facility contribute to the data collected and processed by the AFHE. The AFHE provides the level of accuracy needed for Facility inventory control, as well as providing a form of release detection.

ATGs on each of the Red Hill Facility tanks are calibrated at least once per year. The Navy also verifies ATG measurements after each fuel movement by manually gauging the tanks with a tape measure calibrated annually against a National Institute of Standards and Technology (NIST) traceable standard. Any discrepancies between the ATG measurements and manual gauging greater than 3/16 inch are investigated. In addition, the Navy attempts to detect any unscheduled fuel movements (UFMs) from their UST system by collecting and processing ATG data using the AFHE System. Naval Information Warfare Command administers the AFHE system and control room operators receive alerts of any potential UFM. AFHE accounts for volumes that move through the UST system using flow meters and ATG data combined with strapping charts. Under static conditions, when no fuel is added or removed from the tanks, the AFHE generates a warning alarm any time there is an apparent net loss or gain of more than 1/2 inch of fuel, and a critical alarm for more than 3/4 inch. During scheduled fuel transfers, AFHE generates a warning alarm for more than 1 inch, and a critical alarm for more than 1.5 inches. The ATG is integrated into an alarm system. As part of this system, automated overfill protection is provided should fuel levels exceed certain alarm thresholds. As described in the Response to RFI 11, this system automatically shuts off fuel flow into a tank to prevent fuel from going above a specific elevation in a tank and thereby prevents overflow.

#### 2.2.2 MANUAL FUEL INVENTORY TREND ANALYSIS

The Fuels Department leadership investigates all UFM alarms identified by AFHE/ATG. These investigations document the results in a UFM report. The Fuels Department leadership also conducts a weekly visual trend analysis of ATG data using graphs that cover time periods ranging from several months to more than a year.

#### 2.2.3 SEMIANNUAL TANK TIGHTNESS TESTING

In 2008, the Navy/DLA conducted a Market Survey to research potential candidates for providing a release detection system at the Red Hill Facility (reproduced in Appendix F of the AOC SOW Section 4.2 *Current Fuel Release Monitoring Systems Report*) (DON 2016). In 2009, one method was selected from the candidates and has since been in use as the release detection method applied to all operational USTs at the Red Hill Facility. HAR Section 11-280.1-43 lists the

authorized methods of release detection for field-constructed USTs, such as the ones at the Red Hill Facility. Specifically, paragraph 10A authorizes the use of annual tank tightness testing that can detect a release rate of at least 0.5 gallons per hour. The regulatory agencies established this release detection rate, recognizing any release below this detection threshold would not likely have any adverse impacts on the environment. The Navy currently exceeds the regulatory-mandated time frames for conducting tank tightness testing by conducting testing every 6 months rather than annually. The method used by the Navy has been certified by an independent third party known as the National Working Group on Release Detection Evaluations. This group includes release detection experts from ten states and the EPA.

Tank tightness testing is accomplished by installing a mass measurement system into a UST and monitoring the mass in the tank for a period of 24 hours. As mentioned earlier, mass is measured because volume can change with a change in temperature, whereas mass remains constant unless fuel is moved into or out of a tank. This test is then repeated four additional times to obtain test results for 5 consecutive days. The data from the five tests are then sent for statistical analysis to confirm that the Red Hill tanks are in compliance with state requirements.

Tank tightness testing is just one of many methods the Navy uses to protect human health and the environment by confirming there are no harmful releases of petroleum to the environment from the Red Hill Facility. A release would be detected by the AFHE that monitors the fuel level in the tank down to a 1/16 of an inch (slightly over 300 gallons). Above and beyond that, tank tightness testing is uniquely designed to confirm that there are no small slow releases above the detection limit of 0.5 gph from Red Hill tanks.

The Navy first began tank tightness testing in 2009 as a Best Management Practice. At that time, the State of Hawaii did not require tank tightness testing. In 2015, the Navy began conducting tank tightness testing annually to increase confidence that small releases to the environment were not occurring. In 2018, Hawaii began requiring that tank tightness testing for release detection for tanks like the ones at the Red Hill Facility be conducted once every year. In 2019, in a good faith effort to go above and beyond the state's testing requirements, the Navy began conducting tank tightness testing every 6 months.

Tank tightness testing is a proven method that continues to demonstrate the tanks at Red Hill are tight, and the testing frequency exceeds state requirements. Since tank tightness testing began in 2009, the Navy has conducted over 170 tank tightness tests on all Red Hill tanks containing fuel, and every test has passed.

Although the Navy's goal is committed to prevent the loss of a single drop of fuel to the environment, environmental studies have shown that slow small releases of fuel to the environment are processed naturally by bacteria in the soil and will not impact the environment or human health. This process is described in the AOC SOW Section 6.3 *Investigation and Remediation of Releases (IRR) Report* (DON 2020b).

#### 2.2.4 SOIL VAPOR MONITORING (SVM)

As described in the Response to RFI 6, another complementary release detection method used at Red Hill is SVM. Since 2008, the Navy has measured soil vapor concentrations of volatile organic compounds under all the Facility's active fuel storage tanks on a monthly basis. Currently, the monthly soil vapor monitoring is conducted using a handheld photoionization detector (PID). As described in more detail in the Responses to RFIs 9 and 10, a network of 50 sensors is installed under the 18 active fuel storage tanks (two to three sensors under each tank) (see RFI 9 Figure 1). The SVM system is intended primarily to provide a line of evidence for release detection in support of other detection technologies currently in place. In combination with other data, the system has also helped advance the understanding of petroleum fate and transport (including the weathering of residual fuels held in the vadose zone) at the site.

#### 2.2.5 GROUNDWATER LONG-TERM MONITORING

The Navy established the Red Hill groundwater long-term monitoring network in 2005 with five (5) monitoring locations; the network had expanded to seven (7) locations by the time of the 2014 Tank 5 Release. The Navy has added an additional 13 single- and multi-level wells for a total of 20 groundwater monitoring locations today (as shown on RFI 6 Figures 1 and 2). Additional wells continue to be planned and installed at the time of writing of this document. Groundwater monitoring includes both measuring for the potential presence of fuel product in the wells near the fuel storage tanks (which has never been present in any measurable thickness) and collecting groundwater samples for laboratory analyses. Groundwater monitoring is currently conducted on a quarterly basis, which complements and improves upon the 6-month tank tightness testing frequency. Groundwater monitoring also helps ensure that if hypothetical continuous small releases (or larger releases) were to otherwise escape detection, they would be detected in groundwater.

Additional details related to the groundwater long-term monitoring program, as well as the groundwater monitoring network (including the expansion of groundwater monitoring wells), are provided in the Response to RFI 6.

#### 2.2.6 DRINKING WATER MONITORING

In addition to monitoring the groundwater, the Honolulu Board of Water Supply (BWS) and NAVFAC Hawaii conduct regular testing and publish annual drinking water quality reports known as Consumer Confidence Reports. The reports from both NAVFAC and BWS have always confirmed that the water from all three wells in the area remains safe to drink. As a result of the 2014 Tank 5 release, DOH developed a transition plan to closely monitor the drinking water from the Navy's Red Hill Shaft. Drinking water from the Navy's Red Hill Shaft is now required to be sampled and analyzed at least quarterly. Those reports also verify that the water from Red Hill Shaft is safe to drink.

#### 2.2.7 INSTALLING PERMANENT RELEASE DETECTION IN EACH TANK

The Navy is currently in the process of planning the installation of permanent tank tightness testing equipment in all Red Hill tanks containing fuel, subject to EPA and DOH approval. That upgrade will replace the existing semiannual tank tightness testing program. Permanent installation of this

equipment will provide the capability of on-demand tank tightness testing. This will further reduce the likelihood of a small slow release going undetected.

#### 2.2.8 CONTINUOUS SOIL VAPOR MONITORING (CSVM)

A CSVM sampling and analysis plan is being developed by the Navy in coordination with the AOC Regulatory Agencies as part of a pilot test to determine the efficacy of a site-wide CSVM program. Real-time release detection can reduce the detection time for a hypothetical release from months to days, or even hours. Pending the results of the CSVM pilot test, real-time release detection should be achievable at full-scale implementation after that capability is integrated into a real-time monitoring network. The initial goal of the CSVM network pilot test will be to obtain readings from each SVM port from every 30 minutes to 3 hours, as opposed to the once-a-month readings currently obtained. Results will be provided to the AOC Regulatory Agencies every two (2) months. If the pilot test is determined to be successful, infrastructure will be configured to initially allow for monitoring at the Facility's lower access tunnel gauging station. Eventually, monitoring will be available in the Control Room at Adit 1 in the underground pump house at Pearl Harbor.

Further discussion of SVM at Red Hill, including the proposed continuous system pilot test, is presented in the Responses to RFIs 9 and 10.

### 2.3 Release Response

As described in the following, Alternative 1A includes five categories of different release response measures. As described in more detail in RFIs 11 through 14, this system of release response measures will continue to provide multiple layers of protection and will continue to be further improved as new technologies are available.

#### 2.3.1 EMERGENCY RESPONSE AND ULLAGE PLANS

The *Red Hill Response Plan* (CNRH 2020) outlines necessary critical actions to respond to a release. These actions include notifying the Navy/DLA chain of command and federal and state regulatory agencies (consistent with regulatory requirements), as well as activating a spill response contractor to assist with oil spill response and cleanup in the event a release occurs. The oil spill response strategies vary from minor, small, medium, to large release responses. Operators and watch-standers are primarily responsible for identifying an active fuel release and notifying management. The Control Room Operator takes the next steps necessary to confirm, mitigate, and stop the release. Supervisors then coordinate the overall efforts of the release response. In the unlikely event that a significant release were to occur, operators would notify the Navy/DLA chain of command and federal and state regulatory agencies (consistent with regulatory requirements) and activate a spill response contractor to assist with response and cleanup.

The availability of tank ullage has been identified as being important to managing potential risk (DON 2018c). Ullage is the space available in other tanks to receive and store fuel in the event that fuel needs to be removed from one of the tanks. The Navy revamped its filling procedures in 2020 prior to refilling Tank 5. The Navy now not only identifies the source of the fuel when

developing the fill plan, but also identifies which tanks have ullage and could be used to store the fuel in the event of a release. This allows operations staff to more quickly and deliberately respond, if necessary, to a release from the tank being filled following completion of the TIRM process. Although a formal defueling plan is not prepared for routine operations due to the large variety of Facility configurations that occur due to the various amounts of available ullage, the Control Room Operator and operations staff review available ullage at least once each shift to develop an emergency ullage plan if it becomes necessary to defuel a tank due to a UFM. Additional details related to emergency tank drawdown are provided in the Response to RFI 11.

### 2.3.2 HOLDING CAPACITY

As part of its environmental investigation for the AOC SOW, the Navy analyzed the capacity of the subsurface underneath the Red Hill fuel storage tanks to retain released fuel in naturally occurring lava rock material (basalt) and impede its downward migration to groundwater (DON 2018b, Sections 6 and 9). The analyses considered both hypothetical sudden releases and hypothetical slow releases.

Evaluation of available monitoring data indicated that the 2014 Tank 5 Release (approximately 27,000 gallons of JP-8 jet fuel) was likely retained within the top one-third (approximately 30 feet) of the subsurface between the lower access tunnel (underneath the tanks) and the water table (i.e., the “vadose zone”) with no significant impact to groundwater:

- No light nonaqueous-phase liquid (LNAPL) (i.e., fuel product) was observed in any monitoring well, and there was little to no change in dissolved constituents as measured prior to and after the release as part of a forensics analysis. (In fact, no measurable thickness of LNAPL has ever been observed in any Red Hill groundwater monitoring well.)
- Based on this finding, the 2014 release was used along with site-specific geologic data and data from scientific literature to estimate the vadose zone holding capacity for LNAPL.
- This estimated holding capacity was then used to evaluate the LNAPL volume that would be retained mostly or exclusively in the vadose zone for a hypothetical future release that results in no significant impact to groundwater.

Based on this, and a parallel evaluation of whether groundwater was impacted from the 2014 Tank 5 Release and reached Red Hill Shaft, the 27,000-gallon release of jet fuel:

- Did not result in the observation of LNAPL in any of the Red Hill network monitoring wells.
- Did not result in measurable increases in chemical concentrations in Red Hill Shaft.

The two evaluations focused on understanding and quantifying this “margin of safety” associated with the 2014 Tank 5 release in order to estimate the volume of a hypothetical future sudden release that would not result in exceeding risk-based screening levels at Red Hill Shaft (DON 2018b, at B-i). Updated holding capacity calculations performed for hypothetical future release scenarios (presented in the AOC SOW Section 6.3 IRR Report (DON 2020b, Appendix E) found that a sudden future release of approximately 120,000 gallons of LNAPL (larger than any known historical release) would have, at most, a minimal impact to groundwater and would not likely cause an exceedance of risk-based decision criteria in Red Hill Shaft. In addition, the calculations

showed that a hypothetical slow release of 2,300 gallons per tank per year (6.3 gallons per tank per day) would be degraded within the vadose zone, resulting in at most a minimal impact to groundwater near the tanks, and would not be expected to impact the drinking water quality. Additional criteria were also developed that considered pre-existing LNAPL in the basalt that could potentially lower the holding capacities for releases in different areas of the tank farm. The estimated “Reasonably Conservative and Protective Mid-Range Volume” that can be held in the fractured rock and soils before the fuel migrates to groundwater was estimated to range between 88,000 and 150,000 gallons. Using an additional conservative assumption that basalt beneath the tanks has residual fuel (thus reducing the holding capacity), a correction of 25% was recommended. This then reduces the estimated holding capacity to between 66,000 and 112,500 gallons. Regardless of the exact amount of hydrocarbons that can be assimilated through natural source-zone depletion (NSZD), and the holding capacity, if the assimilative capacity (combination of holding capacity and NSZD) of the basalt is exceeded by an ongoing slow release, or by a larger sudden release, fuel could conceivably reach groundwater, but this is not considered at all likely based on the considerable volume of available data and other protective measures that have been put into place and are being further improved upon. It is important to reiterate that these calculations are necessary to understand the level of risk but should in no way be inferred to mean that the Navy considers any release acceptable. Additional details are provided in the response to RFI 12.

### 2.3.3 NATURAL SOURCE-ZONE DEPLETION (NSZD)

While any fuel release from the tanks to the environment must be avoided, there are important naturally occurring processes that effectively destroy hydrocarbons released into the environment. At Red Hill, a detailed environmental study of NSZD (McHugh et al. 2020) was performed to actually measure the rate at which nature is destroying the fuel that earlier (prior to 2005) escaped the Facility and is believed to be held above the groundwater by the lava rock’s holding capacity. This study used two ways to prove that nature is destroying the spilled fuel using technologies such as “carbon dioxide traps” and “heat flux measurements.”

The scientific work presented in this peer-reviewed paper indicated that at least 4,600 gallons, and potentially as much as 13,000 gallons, of hydrocarbons is capable of being destroyed each year by natural occurring fuel-consuming bacteria in the rocks and soil beneath the tanks. This NSZD process is often referred to as “biodegradation.”

The findings of this study were used to estimate the size of a hypothetical small release that could be balanced by this natural destruction process. The analysis indicated that the naturally occurring

bacteria could prevent a release under 2,300 gallons per year (6.3 gallons per day) from reaching groundwater. If a fuel release were to continue beyond this amount, additional hydrocarbons would enter the fractured rock below the tanks, but at the same time, the naturally occurring bacteria would be removing the same amount. So, at the 2,300 gallons per year level, the contribution from the release would be balanced by the destruction facilitated by the naturally occurring bacteria. While there is some uncertainty in this scientific calculation, the measurements collected at the site confirm what has been observed to occur in every other hydrocarbon fuel release situation around the world: nature is able to destroy petroleum hydrocarbons (at a particular rate, which can vary from site to site). The Navy is in no way relying on the processes described above, but it does appear that the natural environment is providing a layer of protection of its own above and within the groundwater.

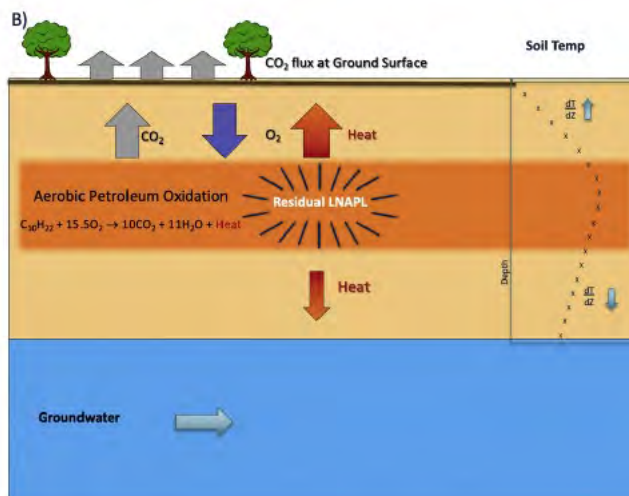

Additional details are presented in the Response to RFI 12.

#### 2.3.4 MONITORED NATURAL ATTENUATION

In addition to the naturally occurring holding capacity and NSZD described above, dissolved fuel constituents that reach the groundwater are also subject to natural biodegradation that mitigates the impacts. If LNAPL were to reach the groundwater, then some of the chemicals would dissolve out of the fuel and into the groundwater. If that groundwater was in the vicinity of the tanks, it would flow toward Red Hill Shaft. During that migration, there are naturally occurring bacteria that could destroy those chemicals in a natural way, similar to the NSZD process, but this time occurring in the groundwater. When this process occurs in groundwater, it is called “natural attenuation.” The method for evaluating this type of attenuation is known as “monitored natural attenuation,” which is recognized by all regulatory agencies as an effective release response strategy under appropriate conditions, especially for fuel-related hydrocarbons.

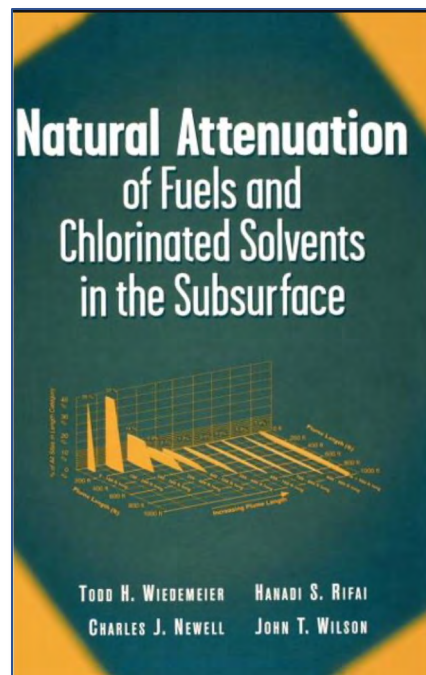

Natural attenuation is a well-understood process, with entire books written about it (Wiedemeier et al. 1999; cover at right) and with detailed guidance that has been developed by environmental regulators like EPA (EPA 1999), which has indicated that natural attenuation is a viable remediation method that can effectively meet remediation objectives that are protective of human health and the environment.



This natural attenuation process is occurring now at the Red Hill Facility. However, the extents of dissolved hydrocarbon are relatively short, often less than 1,000 feet long, and do not extend to Red Hill Shaft due to natural attenuation processes in groundwater called biodegradation, dispersion (natural spreading out of the plume), and mixing of the shallow groundwater plume with clean groundwater from the sides and deeper groundwater.

The AOC SOW Section 6.3 IRR Report (DON 2020b) describes a range of mitigation measures that address both the 2014 27,000-gallon release from Tank 5 as well as a hypothetical large release of 120,000 gallons with the potential to impact groundwater. As described in the IRR Report, a combination of NSZD and natural attenuation are currently mitigating existing subsurface contamination. The Navy will continue to conduct environmental monitoring to ensure that these natural mechanisms continue to effectively mitigate existing impacts.

#### 2.3.5 CAPTURE ZONE/ WATER TREATMENT SYSTEM

As described in detail in the response to RFI 16, the Navy is considering the use of a water treatment plant as a release response measure that may be appropriate if a hypothetical significant future release were large enough to impact drinking water. The capture zone/water treatment system would operate by both establishing a capture zone to limit migration and being able to treat water, if necessary. Further progress on the design, permitting, funding, and construction of the system can advance once the Navy, DOH, and EPA agree upon both the fundamental aspects of the groundwater model and inclusion of this system as part of the proposed TUA Alternative.

### **3 Conclusion**

The Navy has developed a bow-tie diagram (RFI 1 Figure 1) to describe how all elements of release prevention, detection, and release response measures are holistically integrated to protect groundwater. A bow-tie diagram helps to visualize a risk event (such as a release of fuel) along with its root causes, consequences, and risk prevention, detection, and mitigation measures. Use of this tool started in the petroleum industry and is now a widely used tool for risk management throughout a variety of industries. All these elements are described in detail both within this Response to RFI 1 as well as in all subsequent RFIs. As part of this analysis, potential threats relating to a hypothetical release include corrosion and tank integrity, improper operations, improper return to service and tank filling procedures, and nozzle failure. Various release prevention barriers are shown on each threat line and are discussed in this and subsequent responses to RFIs. This demonstrates the steps that the Navy is taking toward ensuring that potential releases are prevented from occurring.

On the right side of the bow-tie diagram, various release detection and response measures are described that minimize consequences to groundwater, should a release occur. A range of potential consequences includes: (1) impact to basalt (but not groundwater); (2) slight impact to groundwater; and (3) impact to groundwater and drinking water.

Each of these three (3) consequences is also associated with a range of fuel releases that have been evaluated as part of various studies conducted by the Navy (further described in the

response to RFI 12), which will also be further evaluated in future analyses to be conducted under the AOC. The release detection and release response barriers help to reduce the three potential consequences described above, in the event that a release occurs. Release detection measures are shown in black. These measures not only exceed federal and state release detection requirements but also work holistically together so that potential releases would be quickly discovered so the release volume is minimized.

Finally, release mitigation measures are shown in gray. Various Navy studies describe the natural processes including fuel retention in basalt, NSZD that degrades fuel retained in the basalt above groundwater, and natural attenuation that degrades fuel constituents that may impact groundwater. While it is the intent of the Navy to have zero releases, these naturally occurring mitigation measures help to minimize the impact to groundwater due in part to how nature degrades fuel in the environment. Taken together, the combination of release prevention, detection, and response measures demonstrates that groundwater is currently well protected, will remain protected, and that the likelihood of an impact to groundwater (and drinking water) is being effectively minimized.

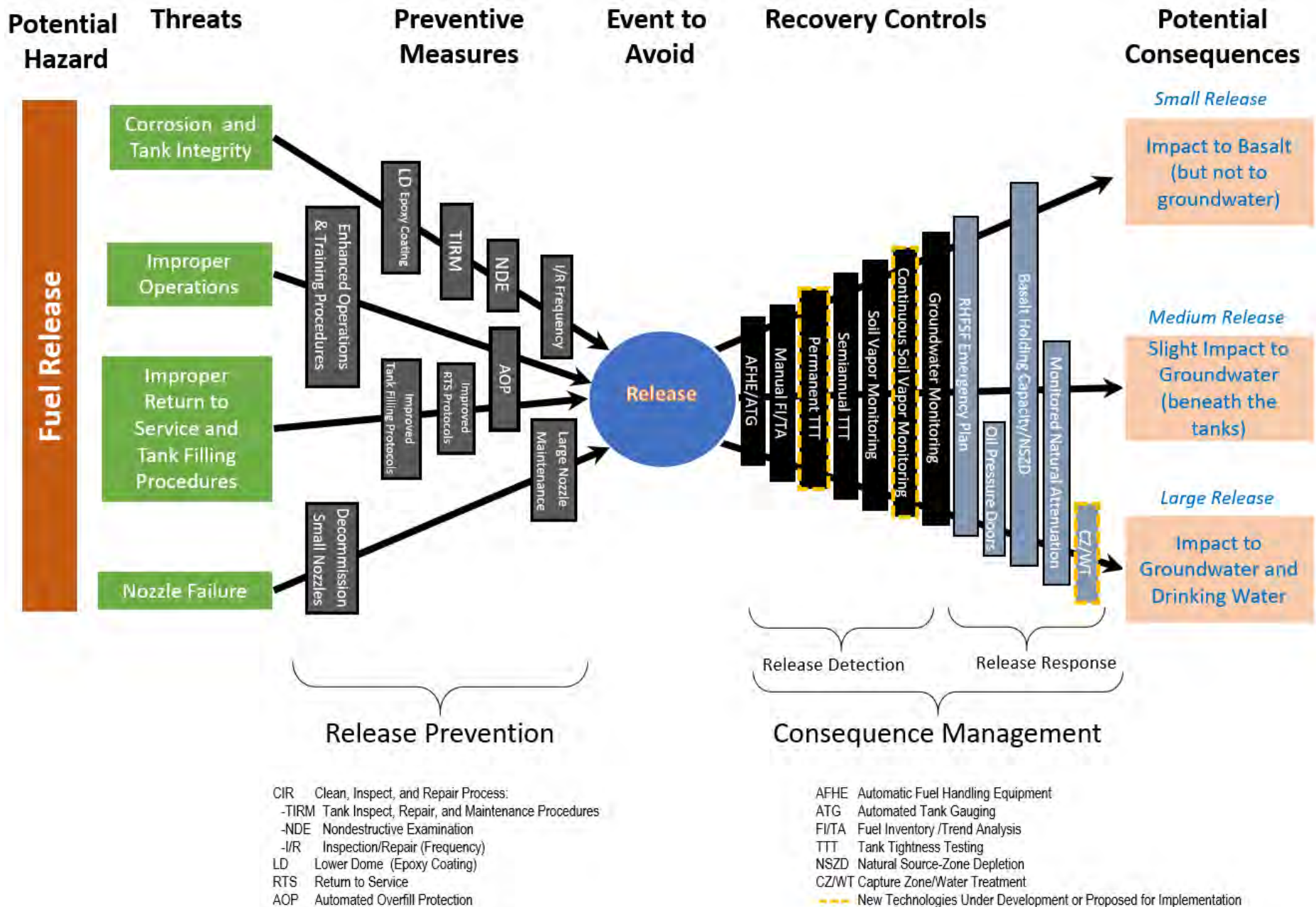

RFI 1 Figure 1: Bow-Tie Diagram for Alternative 1A – Environmental Risk Management

This page intentionally left blank

## Response to RFI 2: Performance of TUA Alternatives in Achieving BAPT

### Regulatory Agencies' Comment:

#### **Insufficient Comparison of Environmental Performance and Justification of BAPT**

The Navy has not adequately discussed the environmental performance of the proposed decision in comparison with the other TUA options. In other words, the Navy has not adequately discussed potential mitigation measures of the proposed alternative in comparison with other alternatives related to protection of groundwater. For a TUA option to be considered BAPT, the Navy needs to demonstrate in the Decision Document that the proposed decision outperforms the other practicable options considered. For example, if secondary containment options outperform single-wall options, then to eliminate the secondary containment options, including new tank option, the Navy needs to demonstrate that each of these secondary containment options are impracticable. If an option is determined impracticable, then the corresponding trade-offs with respect to environmental protection should be discussed.

As discussed in the Regulatory Agencies' letter dated March 7, 2018, we requested that the comparison of environmental performance not only consider the tank vessel and other aspects of the fuel management system, but also the environmental performance during all modes of operation (i.e., recommissioning, static storage, transient storage), and from different release initiating events. This assessment of environmental protection should be more detailed and include a discussion of how each alternative would perform relative to risks of minor, significant, and catastrophic releases and under all modes of operation.

Some of this information is provided in a qualitative manner in Appendix C of the TUA Decision Document, explaining that minor releases are better contained in secondary containment options than the single-wall options, but did not expand in detail significant releases or catastrophic releases or attempt to quantitatively demonstrate potential impact or consequence to groundwater. Use of hypothetical release scenarios for the various modes of operations and type of release (affecting release rates), could be used to assist in estimating potential release volumes (bounding estimates) for each TUA options for comparison purposes.

In addition, the Regulatory Agencies note that not all similar options will have the same environmental protection and should be discussed. For example:

- Per Red Hill Repair Tanks Options Study FISC Pearl Harbor, Hawaii, Final Report, September 2008, page 13, "Visual detection of a leak is the fastest way to detect leaks. Detection by electronic leak detection systems may have a significant time delay before a leak is detected." Only one TUA option provides this capability to visually inspect the outer tank wall and provide secondary containment.
- Additionally, two of the assumptions the Navy has applied to the TUA Decision Document (page 14 of the Decision Document), infer that all proposed TUA options, including new construction, would have the same environmental performance during either a kinetic attack

or a major seismic event without justification. More supporting information and engineering justification need to be given before these assumptions can be made.

Information gained from all other sections of the AOC should be utilized to best complete the comparison. Where there is uncertainty regarding potential impact, especially with incomplete work in other sections, greater conservatism is warranted in the selection of the TUA proposal and identification of BAPT. Following are more specific comments regarding the TUA evaluation.

### **Navy Summary Response:**

As outlined in the Navy's Response to RFI 1, Alternative 1A is the only currently available alternative that meets Best Available Practicable Technology (BAPT) criteria established in the first Tank Upgrade Alternative (TUA) decision. The other potential TUA alternatives described in the Response to RFI 1 and the TUA Decision Document (DON 2019c) do not currently meet BAPT due to issues related to constructability, practicability, reliability, and the ability to be inspected and repaired. Since Alternative 1A is currently the only practicable alternative among those identified, the environmental analyses contained in the Responses to the RFIs (as well as many of the Red Hill Administrative Order on Consent [AOC] deliverable documents) logically focuses on this alternative. The analyses show that Alternate 1A will continue to provide protection for the environment through the continual development of an integrated approach of release prevention, detection, and response measures that are protective of groundwater.

The Navy has committed to identifying and implementing practicable options for secondary containment in the tanks. Specifically, the Navy is committed to the installation of secondary containment by July 15, 2045 and will cease using any fuel tanks at Red Hill that are not equipped with secondary containment by that date. The Navy is continuing to investigate practicable secondary containment tank options and will incorporate any new alternative(s) into the next TUA evaluation and decision, which (as required by the AOC) recur on a 5-year basis after the first TUA Decision is finalized.

Alternative 1A is the best alternative of those currently under consideration not only because it maintains the ability to inspect and repair existing infrastructure, but also because it does not preclude the installation of future secondary containment solutions.

### **Navy Detailed Response:**

As described in the Response to RFI 1, Alternative 1A is the only identified alternative that currently meets BAPT requirements. The other alternatives, including those that may involve some form of secondary containment using the existing liner, are currently impracticable and may preclude future installation of true secondary containment that the Navy is currently investigating. Because the other alternatives are not currently practicable, the Navy has not pursued detailed evaluation of their environmental performance. As future potential TUA alternatives are developed, the environmental performance of any alternative that meets BAPT will be further developed in more detail.

Because Alternative 1A meets BAPT, a detailed analysis of the environmental performance of this alternative, including prevention, detection, and mitigation of any hypothetical future release, is described in detail in the Response to RFI 1. Other responses to these RFIs also describe how Alternative 1A will remain protective of the environment until secondary containment can be installed.

Based on an updated evaluation of key attributes pertaining to BAPT, the remaining alternatives (1B, 1D, 2A, 2B, 3A) did not meet the requirements to be considered as BAPT. The key screening criteria included constructability, practicability, reliability, and the ability to be inspected and repaired. Significant issues pertaining to any of these attributes mean that those alternatives are impracticable for the stated purpose and are therefore ruled out as alternatives from further consideration.

As an example, Alternatives 2A and 2B do not allow for inspection and repair of the outer steel shell, which would continue to be an important component of safeguards that currently protect the environment. While these alternatives would initially be considered as part of secondary containment, the Navy would lose its current ability to perform the detailed inspection, repair, maintenance, and evaluation of the liner and concrete if these alternatives were implemented. Without the ability to inspect and renew the material on an ongoing basis as described in the Regulator-approved AOC Statement of Work (SOW) Section 2.4 *Tank Inspection, Repair, and Maintenance [TIRM] Procedure Decision Document* (NAVFAC EXWC 2017), the tank would eventually become essentially a single-wall tank that cannot be fully evaluated, repaired, and upgraded. Long-term operation of a single-wall tank goes against the commitment from the Navy to ensure that all Red Hill tanks are equipped with secondary containment by July 15, 2045, and implementation of an alternative that does not meet this criterion is not recommended. The detailed environmental evaluation in this (first) TUA decision is limited to those alternatives that meet BAPT and can reasonably be implemented. As described in the Response to RFI 1, the Navy continues to expend considerable resources to evaluate new potential secondary containment alternatives in order to meet its commitments for the future.

This page intentionally left blank



## Response to RFI 3: Analysis of TUA Alternatives and Related Information

### Regulatory Agencies' Comment:

#### **Incomplete Analysis of Alternatives and Missing Information**

##### **[1] Limitations of the NDE Process and Concerns Related to Corrosion Should Be Addressed**

The Navy's Tank Inspection Repair and Maintenance (TIRM) program depends on Non-Destructive Evaluation (NDE) to locate areas of the steel liner that requires repair. Among the assumptions the Navy has applied to the TUA Decision (page 14 of the Decision Document), is that the "4. NDE is a reliable method for detecting corrosion in the tank liner." However, the Navy noted on page 86 of the Decision Document that, "Given the destructive testing results, the Navy is investigating alternatives to improve scanning. The report contains additional recommendation which will be considered by Navy's experts in the continual improvement of TIRM Procedures, including:

1. Analysis of the corrosion rate calculation procedures and recommendations for improvement;
2. Evaluation of results against current corrosion mitigation practices;
3. Recommendations for modification or improvements to TIRM Procedures; and
4. Recommendations for additional destructive testing."

The "Response to Corrosion and Metal Fatigue Practices, Destructive Testing Results Report"

In responding to the AOC SOW Section 5.3.3 *Destructive Testing Results Report* (DON 2019b), the Regulatory Agencies in a March 16, 2020 letter (EPA Region 9 and DOH 2020a) did not agree with the Navy's conclusion that the NDE results are validated, both by destructive testing and by thorough, case-by-case analysis, and are requiring additional studies.

The additional studies that the Regulatory Agencies are seeking are related to improvements on the NDE process, analyses on the condition of the concrete structure and imbedded steel, evaluation of potential causes for corrosion and possible mitigative actions to reduce corrosion rates, and reassessment of repair thresholds to account for inaccuracies in the NDE process, corrosion rates, and possible delays in repair cycles.

While this work is being performed, the concerns raised should be addressed in evaluating TUA options and comparing environmental performance. For example, the Decision Document should explain:

- How the risk due to limitations of the NDE process to detect back side corrosion and weld flaws that could develop into a leak through the steel lining will be addressed; and
- How risk from potential increased back side corrosion of the steel liner, which may be due to lower pH and concrete passivation loss (indicative of a corrosive environment) will be mitigated.

## **[2] Military and Industry Standards Do Not Necessarily Equate to BAPT**

Standards, such as API 653 And MIL-STD-3007F can be useful guidelines in efforts to design, operate, and maintain fuel storage facilities. However, in order to meet the AOC objective of implementing the BAPT at Red Hill, the Decision Document needs to clearly describe the nexus between these standards and the BAPT, considering the Red Hill Facility is a unique facility where many of these standards are not directly applicable.

## **[3] Evaluation of Operational Life and Associated Cost Estimates**

The selection of the alternative that represents BAPT shall be based on several factors listed in the AOC Statement of Work (SOW) section 3, including but not limited to "... (3) *the anticipated operational life of the technology; and (4) the cost of implementing and maintaining the technology.*" The anticipated operational life of each of the options were not discussed in the Decision Document, except for the brief mention on page 32 of an asset study, which to our understanding has not yet been performed. The cost estimates provided on page 31 of the Decision Document only include the initial costs incurred for the implementation of each of the options and does not consider the operational life of each alternative or operation and maintenance (O&M) costs. Incorporating the amortization of capital costs over the operational life of each option, as well as all O&M costs, including those for tank inspection and repair, into the cost analysis will likely provide a better comparison of costs.

It is possible that the New Tank option could be the most cost-effective approach to achieving long-term fuel storage and environmental protection goals. Although the Navy does include a discussion of new tanks in Appendix C of the TUA Decision Document, this evaluation is limited and does not identify all potential environmental protection advantages of new infrastructure. A cost comparison that is not limited to capital costs is particularly important when comparing the New Tanks alternative to the alternatives that utilize the existing tanks as either primary or secondary containment since new tanks would have greatly reduced O&M costs and reduced potential for resource damage costs.

## **[4] Implementation Schedule for BAPT**

Section 3.5 of the AOC SOW states, "*The TUA Decision Document shall define and specify the:...(4) plan and schedule for implementation of the BAPT setting forth the order and schedule that Tanks shall receive BAPT, including a schedule for the start of each tank's budget planning cycle...*" While we have a schedule from the TIRM decision document, the TUA decision document does not clearly state the tank order and schedule for implementation, in relation to contract. The Regulatory Agencies note that the TUA Decision Document may be revised under Section 3.7 of the AOC SOW, and tanks that have already begun their budget planning cycle for a previously approved BAPT, but have not completed installation of that BAPT, shall continue with installation of the previously approved BAPT unless all parties agree to a revised schedule for installing the new BAPT on those tanks. Given the relationship between the implementation of the selected BAPT to the current contract schedule, and to the planned update to the TUA Decision Document, a schedule with all of these components shall be provided in the TUA Decision Document.

## **[5] Performance Criteria for BAPT**

Similarly, Section 3.5 of the AOC SOW states, “*The TUA Decision Document shall define and specify the: ... (5) overall performance criteria for successful application of BAPT. The TUA Decision Document shall either incorporate the TIRM Procedures Decision Document approved by the Regulatory Agencies in Section 2 above, or, consistent with the BAPT identified, incorporate a modified TIRM Procedures Decision Document.*” Because only a general assessment of environmental performance is provided, the performance criteria for the proposed BAPT or a comparison with other alternatives have not been provided. In addition, with the information provided, it is unclear the specific changes to the currently approved TIRM Report that the Navy is seeking. This should be more clearly defined.

## **Navy Summary Response:**

**[1]** To identify and evaluate potential improvements to the Non-Destructive Examination (NDE) process and fully investigate concerns related to potential risk related to back-side corrosion and other issues, the Navy has developed a detailed *Execution Plan* (DON 2020d) in consultation with the Red Hill Administrative Order on Consent (AOC) Regulatory Agencies to conduct ten categories of investigations, analyses, and planning activities designed to improve the NDE and TIRM processes. Together, these investigations, analyses, and planning activities will use the collective expertise of local institutions and national subject matter experts to further refine and update our understanding of the condition of the tanks and the processes affecting NDE and corrosion, evaluate potential innovative processes, and ultimately update the NDE and TIRM processes to continually implement the best available and practicable technologies.

**[2]** The Tank Upgrade Alternatives (TUA) Decision Document was not suggesting that the use of industry or military standards “equates” to Best Available Practicable Technology (BAPT). Rather, a technical standard is a coherent set of definitions, procedures, and processes used widely in the industry by engineers, manufacturers, operators, contractors, and operators of equipment in a reliable fashion. Such standards are typically developed through rigorous peer-reviewed processes, often by the best, brightest, and most experienced people and organizations in a given field. Thus, an element of the BAPT for Red Hill includes the use of standards developed by the collective experience of the American Petroleum Institute (API), the American Society for Mechanical Engineers (ASME), the American National Standards Institute (ANSI), and various components of the Department of Defense (DoD), who bring a wide variety of experience and expertise to bear. Thus, such standards do not “equate” to BAPT, but are used at Red Hill to implement BAPT in a manner that increases safety, reduces variability, maximizes efficiency, and ensures the highest quality work.

**[3]** Life cycle costs for each alternative over a 50-year planning horizon were prepared in the AOC Statement of Work (SOW) Section 3.0 TUA Report (DON 2017a) and are summarized in Section 3 below.

**[4]** The implementation schedule is provided in Section 4 below.

[5] Performance criteria for BAPT are detailed in the Responses to RFIs 1 and 2, and the TIRM process has its own built-in performance metrics, some of which are described in Section 5 of the Detailed Response, below.

## **Navy Detailed Response:**

### **1 Potential Limitations of the NDE Process and Concerns Related to Corrosion Will Be Addressed by Implementation of the Execution Plan for AOC SOW Section 5.4**

The Navy has expended and continues to expend considerable effort to improve the TIRM process, including NDE of the tank liners, in consultation with subject matter experts and the regulatory agencies. Work is currently underway under AOC SOW Section 5.4, “Decision on Need for and Scope of Modified Corrosion and Metal Fatigue Practices,” to improve the NDE process. The work will also further address the concerns related to corrosion expressed in the AOC Regulatory Agencies’ July 7, 2020 letter (EPA Region 9 and DOH 2020b) regarding the AOC SOW Section 5.3.3 *Destructive Testing Results Report* (DON 2019b); the letter’s concerns reflect the concerns in this RFI. To address them, the Navy has held discussions with the AOC Regulatory Agencies, resulting in the Navy preparing and submitting an *Execution Plan* for AOC SOW Section 5.4. The *Execution Plan* details ten categories of additional analyses and planning efforts designed to address these concerns and improve the NDE and overall TIRM processes. The following sections describe the work that will be conducted pursuant to the *Execution Plan* and provide responses to specific RFI 3 comments and questions.

#### **1.1 AOC SOW Section 5.4 Execution Plan**

Pursuant to the AOC Regulatory Agencies’ letter dated March 16, 2020 (EPA Region 9 and DOH 2020a) in response to the Navy’s AOC SOW Section 5.3.3 Corrosion and Metal Fatigue Practices *Destructive Testing Results Report* (DON 2019b), discussions were held among the AOC Parties to address the concerns identified in the letter. These discussions resulted in the AOC Regulatory Agencies’ July 7, 2020 letter (EPA Region 9 and DOH 2020b) regarding the AOC SOW Section 5.3.3 *Destructive Testing Results Report* (DON 2019b). This letter acknowledged that there are disagreements and that the substance of those may be further examined in work yet to be performed under AOC SOW Section 5.4.

The AOC Parties held Section 5.4 scoping meetings between July and December 2020. The result of these meetings was development of the AOC SOW *Section 5.4 Execution Plan, Decision on Need for and Scope of Modified Corrosion and Metal Fatigue Practices* (DON 2020d) (reproduced as Appendix A). The *Execution Plan* outlines ten documents that the Navy/Defense Logistics Agency (DLA) will prepare to further evaluate the current NDE process, conduct research and studies to improve the current process, and update NDE and TIRM procedures and processes. Per the *Execution Plan*, the Navy/DLA will conduct the following analyses and prepare the following documents:

1. *Navy/DLA Interpretation of the Coupon Results*. This report will address several of the AOC Regulatory Agencies’ statements made in their March 16, 2020 letter (EPA Region 9 and DOH

2020a) in response to the Navy's execution of AOC SOW Section 5.3.3; it will also clarify several of the anticipated results to the scope of the testing. This document will provide a more thorough comparison of the results of the destructive testing to the non-destructive testing results.

2. *Preliminary Liner Corrosion Assessment Report.* This assessment will discuss how the currently used corrosion rate assumptions were developed by using past information and additional research, including how those rates are verified during tank inspections and how factors of safety are employed to increase protectiveness. The report will provide the basis for justifiable corrosion rate assumptions and re-evaluate the repair threshold and associated factor of safety, all of which will be used to enhance the TIRM protocols. The overall purpose of using corrosion rate assumptions is to ensure that the tank liner will not be corroded to the minimum thickness prior to the next inspection, and to ensure the prevention of releases due to tank liner corrosion.
3. *Preliminary Concrete Assessment Report.* Analyses will be conducted to assess the physical, chemical, and mechanical properties of the concrete structure and embedded reinforcing steel. The preliminary report will discuss the quality and durability of the concrete located between the tank and the basalt with reference to the American Concrete Institute 3641R-19 *Guide for Assessment of Concrete Structures Before Rehabilitation* (ACI 2019). The concrete assessment will provide a better understanding of the service life of the structure as well as inform other characteristics that influence rates of corrosion of the tank liner or the potential for corrosion in the steel reinforcing bars (rebar) that are embedded in the concrete.
4. *Inspect and Repair Protocols Project for Red Hill Underground Storage Tanks.* The Navy has engaged experts at the University of Hawaii (UH) Department of Engineering's Corrosion Laboratory to research how NDE is affected by corrosion products on the steel, develop protocols to measure site specific corrosion rates, and evaluate repair and patch protocols. The work by UH will be peer-reviewed by an independent corrosion expert. This report will provide information that may be used to update and improve the NDE and TIRM processes.
5. *Concrete Tank Degradation Inspection and Retrofit.* The Navy has also engaged experts at the UH Department of Engineering's Corrosion Laboratory to research the potential for degradation and cracking of the concrete at Red Hill, which has not been observed, including chemical and mineralogical analysis of potential causes and degradation mechanisms. If indicated, the report will investigate potential mitigative technologies. The work by UH will be peer-reviewed by an independent concrete expert. This report will provide information that may be used to update and improve the TIRM process.
6. *Element, Phase, and Oxidation State Mapping of Red Hill UST Corrosion by Advanced Microscopy Methods.* The Advanced Electron Microscopy Center at UH will perform element-, phase-, and oxidation-state mapping of coupons extracted from out-of-service Red Hill tanks as well as laboratory-generated corrosion samples produced in collaboration with the efforts conducted for Report 2, above. This research will be carried out in a focused-ion-beam scanning electron microscope and a scanning transmission electron microscope using

electron imaging, energy dispersive X-ray spectroscopy, and electron energy loss spectroscopy to visualize structure, morphology, and corrosion product phases and distributions, and provide in-depth analysis of the corrosion structure and the episodic corrosion history. The work by UH will be peer-reviewed by an independent corrosion expert. This report will provide information that may be used to update and improve the TIRM process.

7. *Inspection Data, LFET [Low-Frequency Electromagnetic Technique], and Step 2 Analysis Report.* The Navy will investigate potential state-of-the-art NDE technologies and evaluate the potential for using different or additional methods to improve the overall NDE process; conduct a study to determine the likelihood of detecting defects; investigate improvements to the current NDE process by implementing changes to NDE software; qualify NDE technicians; assess human factors to identify process improvements; and research the 2-step process that is currently being used to determine whether other methods or procedures may be appropriate. This report will provide information that may be used to update and improve the TIRM process.
8. *Robotic Inspection Report.* The Navy will compare the procedures and results from a robotic inspection to a previously performed inspection using human testers. The two inspections will be conducted on the same non-Red Hill bulk fuel storage tank. Results of the comparison will inform Navy decisions on whether prescribing robotic means at Red Hill has technical merit.
9. *TIRM Update Report.* Based on the results of the investigations and evaluations described in the eight studies above, the Navy will update the TIRM procedures, as appropriate. Improvements may include changes to NDE execution, data entry, and documentation, inspection and repair specifications, infrastructure modifications, and changes to quality control and quality assurance measures. The changes to the TIRM process are expected to further advance improvements already made to the NDE and TIRM processes, increase confidence in the inspection and repair of the Red Hill tanks, and further reduce the current low risk of developing liner hole prior to a tank's next inspection.
10. *Overall Corrosion Assessment Report.* The Navy will summarize the results, findings, and recommendations of all the studies and investigations described above, and will provide a synopsis of the current status of the condition of the Red Hill storage tanks.

The work for Documents 2, 3, 4, 5, 6 and 10 had already been initiated by the Navy/DLA prior to receipt of the AOC Regulatory Agencies' July 7, 2020 letter regarding work under AOC SOW Section 5 (EPA Region 9 and DOH 2020b), and the AOC Parties agreed that the additional studies and reports listed above were appropriate to address concerns with the NDE process and corrosion.

## **1.2 Responses to Specific Comments Regarding the NDE Process and Corrosion**

The reports and studies described above are designed to address the four specific comments regarding NDE and corrosion in RFI 3. First, regarding "*analyses of the concrete structure and embedded steel for evaluation of potential causes for corrosion and possible mitigative actions to reduce corrosion rates*":

- The *Preliminary Concrete Assessment Report* (Document 3, above) will analyze the condition of the concrete structure and embedded steel. The analysis will be based on testing of the concrete pursuant to the principles of the American Concrete Institute.
- If the *Preliminary Concrete Assessment Report* (Document 3) concludes that the current concrete conditions pose concerns, the *Concrete Tank Degradation Inspection and Retrofit* (Document 5) will include investigations, analyses, and recommendations for the best practicable solution to address any identified shortcomings.

Second, regarding “*reassessment of repair thresholds to account for inaccuracies in the NDE process, corrosion rates, and possible delays in repair cycles*”:

- The *Preliminary Liner Corrosion Assessment Report* (Document 2) will address the science behind the calculation of site-specific corrosion rate assumptions using (1) the NDE results of the most recent Red Hill tank inspections, (2) the API 653 process, and (3) comparisons between other industries’ practices. This document will address the variability and changes in corrosion rates throughout the life of a structure and will investigate whether changes to the calculations or methodology are warranted.
- The *Inspect and Repair Protocols Project for Red Hill Underground Storage Tanks* (Document 4) will also study the site-specific corrosion rates under the conservative and potentially unrealistic assumption that current NDE processes do not measure the actual corrosion due to adherent corrosion products. This study will also evaluate the current API 653 repair protocol to ensure that the processes are protective. A peer review of the document will evaluate the assumptions and the results from this study, which may result in changes to the NDE process, calculated corrosion rates, and repair cycles.
- The *Element, Phase, and Oxidation State Mapping of Red Hill UST Corrosion by Advanced Microscopy Methods* (Document 6) will examine the existing corrosion product behind the steel liner. Using advanced microscopic techniques, it may be possible to “date” the product and determine if it is “old” or “recent.” This study will assist in determining corrosion rates, which may result in changes to the NDE calculations, if appropriate.

Collectively, these investigations and reports will ensure that the TIRM process continues to use appropriate corrosion rates, protective repair thresholds, and appropriate repair cycle intervals, which will be re-evaluated based on the best available and practicable science and technologies. This protectiveness is expected to remain bolstered by the Navy’s continued use of a safety factor of 2 when calculating corrosion rates and performing tank repairs.

Third, regarding “*How the risk due to limitations of the NDE process to detect back side corrosion and weld flaws that could develop into a leak through the steel lining will be addressed*”:

- The *Inspection Data, LFET, and Step 2 Analysis Report* (Document 7) will provide the results of additional testing and analyses of the NDE process and procedures, including a probability of detection study that will quantify the current limitations, and refinements to the LFET NDE process, the current Phase Array Ultrasonic Testing process, and other methods for corrosion and weld flaw detection and mapping.

- The *Robotic Inspection Report* (Document 8) will evaluate whether additional innovative methods may be available and practicable to improve the NDE and TIRM processes.
- The *TIRM Update Report* (Document 9) will incorporate the results of all these analyses into updated TIRM processes. These processes will be definitized in updated Construction Contract Specifications and in the Government Quality Assurance Procedures. Factors of safety will continue to be employed to ensure continued tank integrity.

Fourth, regarding “*How risk from potential increased back-side corrosion of the steel liner, which may be due to lower pH and concrete passivation loss (indicative of a corrosive environment), will be mitigated*”:

- The *Preliminary Liner Corrosion Assessment Report* (Document 2) will evaluate the potential for increased rates of corrosion, including the method by which the corrosion rate is calculated, assess use of extreme value rates to establish minimum remaining thickness, environmental and chemical conditions affecting rates, potential causes for corrosion, potential corrosion impact from use of old versus new carbon steel patch plates, and potential galvanic corrosion between new patch plate and old carbon steel liner. These and other analyses may result in changes to the calculation of corrosion rates and factors of safety.
- The *Preliminary Concrete Assessment Report* (Document 3) will evaluate not only the condition of the concrete but also the potential for corrosion in the reinforcement, including investigations of the physical, chemical, and mechanical properties of the concrete that affect the potential for corrosion.
- The *Overall Corrosion Assessment Report* (Document 10) will combine the results of these and the other studies (i.e., Document 4: *Inspect and Repair Protocols Project for Red Hill Underground Storage Tanks*, Document 5: *Concrete Tank Degradation Inspection and Retrofit*, and Document 6: *Element, Phase, and Oxidation State Mapping of Red Hill UST Corrosion by Advanced Microscopy Methods*) into a unified synopsis of conditions related to corrosion in the Red Hill storage tanks. The *TIRM Update Report* (Document 9) will incorporate the results of these analyses into appropriate updates to the TIRM procedures.

The objective of the above studies and investigations is to evaluate potential improvements to the current tank inspection and repair processes. Any such improvements, along with all the other work and analyses the Navy is performing, can help decrease the risks associated with locating corrosion that can potentially affect the hydraulic integrity of the steel and concrete tank structure, with the goal of preventing any release during the service interval between Clean, Inspect, and Repair (CIR) events. The improvements that will be incorporated into the TIRM process will increase confidence in achieving this goal.

## **2 Military and Industry Standards Do Not Necessarily Equate to BAPT, but Provide Proven and Reliable Methods for Implementing BAPT**

The industry standards referenced in the TUA Decision Document are not intended to “equate” to BAPT, nor should these standards be misinterpreted as something that should equate to BAPT. Rather, the Navy uses industry standards to provide “useful guidelines” to aid in the identification of BAPT and to “design, operate, and maintain fuel storage facilities” in accordance with BAPT.



The use of standards in this manner is consistent with industry best practices and the comment from the AOC Regulatory Agencies.

A technical industry standard is a coherent set of definitions, procedures, and processes used widely in the industry as instructions for engineers, manufacturers, contractors, and equipment and Facility operators. Such standards are typically developed through rigorous peer-reviewed processes, often by the best, brightest, and most experienced entities in a given field. Standards relevant to the Petroleum, Oil, and Lubricant (POL) refined products industry are typically written, published, and maintained by organizations such as the API and engineering societies such as the American Society for Mechanical Engineers. American National Standards must be developed under an accreditation program by ANSI, an organization that establishes requirements for standard-setting organizations. Only approved standards developers are allowed to sponsor documents for approval by ANSI. This third-party accreditation ensures technical rigor and is routinely relied on by federal and state regulators. Moreover, standards are periodically updated to reflect developments in the availability and practicability of various technologies and procedures.

The API standards program was established in 1924 to write, publish, and maintain consensus standards for the oil and gas industry. API has developed more than 700 standards that address all aspect of the oil and natural gas industry. API standards, developed using an ANSI-accredited process, are widely used by companies in the United States and around the world. API standards are frequently referenced in federal and state regulations.<sup>2</sup>

MIL-STD 3007G is a DoD standard that establishes policy for developing and maintaining Unified Facilities Criteria (UFC), Facilities Criteria (FC), and Unified Facilities Guide Specifications (UFGS) as common facility standards and engineering practices for the DoD and other supported agencies. UFC, FC, and UFGS provide facility planning, design, construction, operation and maintenance, sustainment, restoration, and modernization criteria for facilities owned by the DoD. There are many UFCs and UFGSs, each one prepared for the various classifications of real property facilities.<sup>3</sup> The UFC Program draws upon a host of working groups comprising various experts from each participating organization to draw upon their collective expertise and experience to develop the technical standards. All DoD components are *required* to use the UFC and the UFGS “to the greatest extent possible” for planning, design, construction, restoration, and modernization of a facility such as the Red Hill Facility.<sup>4</sup> Guide specifications are broad in reach and must always be tailored to the specific site and project requirements.

Performing work in accordance with the DoD specifications increases safety, provides a concise structure to control of quality of work, reduces variability in costs, reduces duplication of effort, minimizes waste of resources, helps ensure fairness in contract competition, and ensures quality, function, and performance. Using these specifications to execute the identified BAPT at Red Hill

<sup>2</sup> <https://www.api.org/products-and-services/standards/>

<sup>3</sup> <https://www.wbdg.org/ffc/dod>

<sup>4</sup> <https://www.esd.whs.mil/Portals/54/Documents/DD/issuances/dodd/427005p.pdf?ver=2018-11-08-080607-280>

mitigates many sources of variability in work, ensuring reliability, and efficiently incorporates many relevant industry standards. For example, the Navy uses a UFGS section to specify minimum administrative, procedural, material, and performance requirements to manage the quality of work. This specification section sets forth specific actions, deliverables, responsibilities, and industry standards that must be met by the contractor to ensure the quality of the work. By using a standardized quality control program, the chances of an unacceptable outcome are greatly reduced.

The BAPT at Red Hill is implemented in part by DoD specifications that, in recognition of the unique nature of Red Hill, were specifically created for use at Red Hill to control tank inspection and repair work. The sections were incorporated into AOC SOW Section 2 TIRM procedures,<sup>5</sup> which have been approved by the AOC Regulatory Agencies. The specifications standardize many elements of the inspection and repair process such as using a two-step process to screen metal for corrosion and then prove-up indications of corrosion by measuring metal thickness using a different technician and technology. Other specification sections are edited to be site-specific to Red Hill. Use of edited site-specific specifications is an execution element of the BAPT that implements the TIRM procedures and provides a specific framework for incorporating important lessons learned and continuous improvements into future work. Each guide specification references numerous standards published by industry and thus becomes a concise set of requirements which must be satisfied by submittals, products, and execution.

The Navy's inspection and repair work at Red Hill is done in general accordance with the API 653 Standard, as modified to reflect conditions at the Facility. API 653 was written for aboveground storage tanks (ASTs), so some aspects do not apply (e.g., visual inspection of the exterior of the tank barrel). However, other sections of API 653, such as those related to the tank bottoms of ASTs (the outside of which, like the Red Hill tanks, cannot be visually inspected) can be directly applied to Red Hill and are therefore incorporated into the TIRM. Thus, an element of BAPT for the Red Hill tanks is inspection and repair of the steel tank liners in accordance with API 653 methods for inspecting the bottom portion of an aboveground storage tank. To apply as many aspects of API 653 as possible in execution of the BAPT, the Navy applies the principles prescribed in API 653 Standard in the contract documentation, which includes use of the unique DoD Specifications, and leverages the expertise involved in creating those specifications.

### **3 Summary of Operational Life and Associated Cost Estimates**

Life cycle cost analyses were performed for each of the six TUA alternatives for a 50-year period in the TUA Report (DON 2017a, pg. 193). As requested in the comment from the AOC Regulatory Agencies, these life cycle cost analyses amortized capital costs and O&M costs, including those for tank inspection and repair, over the expected 50-year life. The total life cycle costs were estimated to be:

<sup>5</sup> <https://www.epa.gov/red-hill/tank-inspection-repair-and-maintenance-red-hill>

- Alternative 1A:
- Alternative 1B:
- Alternative 1D:
- Alternative 2A:
- Alternative 2B:
- Alternative 3A:

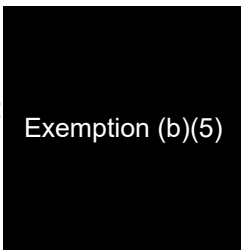

In addition, while the Navy conducted an *Alternative Location Study* (NAVFAC EXWC 2018) to evaluate potential locations for new tanks, those options were not identified among the feasible alternatives analyzed in the AOC Regulatory Agency-approved TUA Report, and will be considered separately. New facilities at alternative locations also do not fit within the AOC definition of BAPT, i.e., technologies that “can be applied to the in-service Tanks at the Facility.”

#### 4 Proposed Implementation Schedule for BAPT

The proposed BAPT implementation schedule assumes a 20-year CIR interval and a 36-month duration for each tank. RFI 3 Figure 1 depicts the proposed schedule for BAPT implementation and displays the assumed timeline for future updated TUA decisions. Each decision is based on an assumed 5-year timeframe starting from approval of the previous TUA decision. As new TUA alternatives are developed, they may be considered in future TUA Decision Documents based on their ability to meet BAPT requirements as well as their ability to provide increased environmental protection.

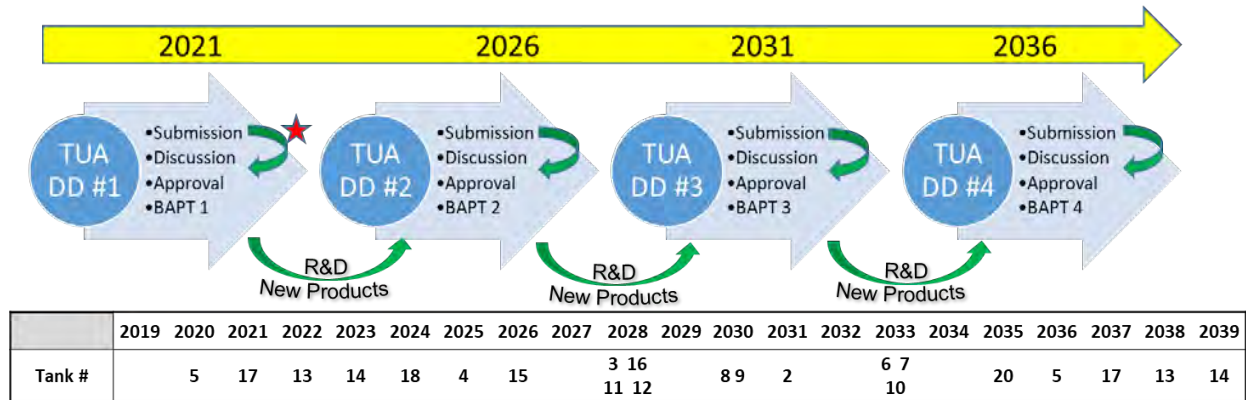

**RFI 3 Figure 1: Proposed BAPT Implementation Schedule as Part of the Clean, Inspect, and Repair Process**

RFI 3 Table 1 shows the proposed CIR schedule, which demonstrates that the CIR process can be completed within a 20-year recurrence interval.



## **5 Performance Criteria for BAPT are Detailed in the RFIs 1 and 2 Responses, and the TIRM Process Has Its Own Built-In Performance Metrics**

The overall performance criteria for BAPT are based on a comparison of the attributes that were evaluated in detail in the TUA Report (DON 2017a) and the TUA Decision Document (DON 2019c) and the environmental protectiveness of the available and practicable alternative or alternatives. These performance criteria are discussed in detail in the RFIs 1 and 2 Responses.

In addition, as an important component of Alternative 1A, the alternative that is recommended for implementation in the current BAPT review cycle, the approved TIRM process has its own built-in performance metrics and other safeguards. Successful implementation of the TIRM process is a key element in the prevention of releases to the environment. Therefore, as described in the previous section, the Navy has adapted the API Standard 653 “Tank Inspection, Repair, Alteration, and Reconstruction” (API 2014) standards for use at Red Hill. The AOC SOW Section 2.2 TIRM Report (NAVFAC EXWC 2016) incorporated these and other appropriate procedures in defining the processes of inspection, repair, and maintenance of the Red Hill Facility with the goal of maintaining tank tightness and preventing releases. The AOC SOW Section 2.4 TIRM Decision Document (NAVFAC EXWC 2017) incorporated the adapted API 653 procedures and was approved by the AOC Regulatory Agencies (EPA Region 9 and DOH 2017). Under this process, which the Navy continues to improve, every tank has passed every tightness test conducted.

In summary, the TIRM process begins following a verified tank tightness test with draining the tank, degassing, and cleaning to achieve conditions suitable for personnel to enter and safely perform repair work. An API 653-certified inspector visually inspects the tank to assess its condition and integrity. The next step involves a highly detailed inspection of the entire interior surface of the tank (over 84,000 square feet and 4.5 miles of welds). Qualified NDE technicians perform the tank interior scanning. Before being allowed to perform inspections inside the tank, each NDE technician must successfully pass a blind test on site to confirm they can identify defects on both coated and uncoated plates. The results of these evaluations are documented and kept on file. The thickness of the steel plates is manually scanned in an overlapping pattern using LFET instruments. Phased Array Ultrasonic Technique (PAUT) is used to confirm indications resulting from the LFET inspection. Balanced Field Electromagnetic Technique (BFET) is used to scan the condition of the welds joining the steel plates; Ultrasonic Shear Wave Technique is then used to measure the depth of detected weld indications. Independent “prove-up” inspections are followed up by the API 653 certified inspector using PAUT equipment. The API 653 inspector identifies areas requiring repair. At the sites requiring repair, the PAUT prove-up scan is used to further measure the steel liner thickness beyond the repair locations so that steel patch plates can be properly sized to ensure the plates are lap-welded to original steel liner with adequate thickness.

The API 653-certified inspector also conducts a second visual inspection of the entire tank interior. API 653 inspectors have stated they can usually visually identify 90% of the defects. However, typically less than 2% of the interior surface area of the tank requires repair with patch plates.

A comprehensive list of findings and recommended repairs is submitted to the Navy for review and approval as a Preliminary Condition Assessment Report. The Navy/DLA review and approve this report and the list is published as the Tank Repair Recommendations; approval of these Recommendations by the Navy/DLA forms the basis for funding and authorization for the contractor to perform repairs.

Repair design is performed by a licensed professional engineer experienced in storage tank design. Locations requiring patch plates are evaluated for distance to existing weld seams and spacing relative to adjacent repairs as required by API 653. Patch plate dimensions and shapes are designed for each repair location. The patch plate is serialized to confirm it is installed in the proper location. Locations requiring weld joint repairs are ground out and independently inspected for proper preparation prior to performing the weld repair.

After completion of each patch plate or weld repair, each location undergoes NDE of the repair by a certified inspector who did not perform the welding. These tests include visual inspection, magnetic particle inspection, and vacuum box inspection. The dates and initials of personnel completing repairs and inspections are recorded at each repair location inside the tank and documented so accountability can be maintained. An initial final inspection is performed by API 653-certified inspectors before a second inspection is completed by a senior Navy engineer to verify that repairs were adequately completed and documented. The contractor's Tank Engineer and API 653 inspector issue a Suitability for Service Testament that the tank is satisfactory for service. Finally, the Commanding Officer of NAVFAC HI, a Navy Civil Engineer Corps Captain who is also a licensed professional engineer certifies that the construction is complete on each Red Hill tank before it can be filled.

Due to the inspection technology employed and the additional quality control procedures that have been implemented, the cost for the current TIRM process at the Red Hill Facility is much more than in past years. Prior to 2014, the Navy/DLA spent in the range of \$5–6 million per tank. Following 2014, cleaning, inspection, and repair of a Red Hill tank can approach approximately \$30 million per tank.

The Navy also continues to research better ways of identifying every location requiring repair during the TIRM process. This is occurring despite only 2 percent of the total surface area typically requires repair and despite the low risk associated with missing a repair area that is significant enough to develop a through hole prior to the next 20-year CIR process. For example, the thinnest section of steel liner identified in Tank 14 in the AOC SOW Section 5.3.3 *Destructive Testing Results Report* (DON 2019b) was still nearly half the thickness of the original steel liner and would have remained intact for many more years. This ongoing effort to improve the TIRM process is being pursued through the work identified for AOC SOW Section 5.4 in the *Execution Plan* (DON 2020d) described above. Successful implementation of the TIRM process is a key element in the prevention of releases to the environment

## Response to RFI 4: Evaluation of Hydraulically Protective Tank Coatings

### **Regulatory Agencies' Comment:**

#### **Experimental Pilot Project to Fully Coat Interior Surface of a Tank Requires Detail**

On page 13 of the Decision Document, under “Additional Improvement—Mid-Term/Long-Term,” the Navy proposes to evaluate fully coating the interior surface of one tank as a pilot if laboratory testing, to be completed by the end of September 2019, indicates the coating could act as a hydraulic barrier/liner and provide corrosion resistance. The Regulatory Agencies recognize that this is not a commitment to a proposal, nor a formal request for a pilot program. Should the Navy decide to pursue a pilot, information required under Section 3.6 of the AOC SOW shall be submitted for review by the Regulatory Agencies. Such information includes, but is not limited to, the overall operational design of the pilot program; the technology and procedural aspects of the pilot; and the performance criteria and method of evaluating the success of the pilot program. Any proposal for a pilot shall also describe how the action will mitigate risk to the environment.

The Regulatory Agencies note that the proposed epoxy coating will not address backside corrosion concerns on the steel liner but may potentially seal porous welds and other small defects, as is currently applied to new weld joints during the clean, inspect, and repair process.

### **Navy Summary Response:**

Preliminary evaluation of commercially available protective coating systems found no evidence that coating could perform as a hydraulic barrier in a steel-lined fuel tank. The result was consistent with market research, the lack of relevant performance data, and system manufacturer warranties.

The Navy will not pursue investigating performance capabilities of protective coating systems as a hydraulic barrier. Applications of coating on Red Hill tanks will continue to be applied to supplement the existing protective coating system and perform as an inner (product-side) corrosion barrier.

### **Navy Detailed Response:**

Subsequent submittal of the 2019 Tank Upgrade Alternatives (TUA) Decision Document, a preliminary evaluation investigated the hypothesis that the performance capability of a hydraulic barrier could be provided by a commercially available epoxy coating system. Manufacturers of epoxy coating systems do not support this capability, and currently, no data or evidence exists to support this type of performance outside of its intended use. Warranty information excluded product use as all or part of a hydraulic barrier. No evidence was found of any performance capability for an epoxy protective coating system to be used as a hydraulic barrier in a steel-lined fuel tank. Further tests are not planned. Epoxy coating systems are intended by the manufacturers

and warranted for use as a corrosion barrier. The Navy commonly uses epoxy protective-coating systems for that purpose and will continue that practice.

The Navy concurs with the Regulatory Agencies that epoxy coating will not address backside corrosion and has elected to pursue other initiatives to improve responses to backside corrosion under AOC SOW Section 5.4. The AOC SOW Section 2.4 *Tank Inspection Repair and Maintenance (TIRM) Procedure Decision Document* provides details on how Red Hill tank hydraulic and structural integrity is maintained (NAVFAC EXWC 2017). Maintenance and application of protective coating systems in use as a corrosion barrier will also be performed pursuant to principles of the TIRM integrity management program procedures.



## Response to RFI 5: Upgrading Tanks to Secondary Containment by July 15, 2045

### **Regulatory Agencies' Comment:**

#### **The Navy's "Double-Wall Equivalency Secondary Containment Or Remove Fuel From Red Hill In Approximately the 2045 Time Frame" Requires Further Discussion**

This proposal is provided under "Studies Concerning the Future of the Facility," on page 31 of the Decision Document. It is not tied to any TUA option currently before us, and therefore is not clear how this plan is intended to be implemented. If the Navy wants to incorporate this concept in a future submission as a new TUA option, please consider the following:

1. Double-wall equivalency secondary containment needs to be defined. There are regulatory definition and requirements for secondary containment. The objective of secondary containment for underground tanks is risk mitigation. Secondary containment has the potential to contain both acute and chronic releases. As we have previously specified as our expectation for comparative environmental performance, the Navy must present a detailed comparison of how the proposed secondary containment equivalency will perform against the other options, including the secondary containment options. If equivalent risk mitigation measures cannot achieve that of secondary containment, then the Navy needs to clearly define and justify their alternative plan and schedule to achieve risk mitigation adequate to protect the water supply. All other required information necessary to compare this option with the other proposed TUA options must also be provided.
2. Section 3.5 AOC SOW specifies that all tanks in operation shall have deployed Regulatory Agencies' approved BAPT by September 2037 or be taken out of use, temporarily closed, and emptied of all regulated substances or permanently closed pursuant to applicable regulations or as approved by the Regulatory Agencies. Currently, the 2045-time frame does not appear to comply with section 3.5 AOC SOW agreed upon deadline for BAPT tank compliance.
3. State of Hawaii UST regulations (section 11-280.2-21(c)) for airport hydrant fuel distribution systems and UST systems with field-constructed tanks require by July 15, 2038, that "...tanks and piping installed before the effective date of these rules must be provided with secondary containment that meets the requirements of section 11-280.1-24 or must utilize a design which the director determines is protective of human health and the environment...". Similarly, there is no information to support that this proposal will comply with state regulations.

### **Navy Summary Response:**

By July 15, 2045, the Navy intends to upgrade all Red Hill tanks with secondary containment, including an inner and outer barrier with an interstitial space that is monitored for releases. This is an additional commitment above and beyond the current Best Available Practicable Technology (BAPT) decision contained in the 2019 Tank Upgrade Alternatives (TUA) Decision Document. The Navy remains committed to the Administrative Order on Consent (AOC) and will implement this and future BAPT decisions for all Red Hill fuel tanks by the 2037 AOC deadline. Regarding its long-term commitment to secondary containment of Red Hill fuel, the Navy intends to fully

comply with the technical details of secondary containment, as defined in Hawaii Administrative Rules (HAR) Section 11-280.1-21(c), and will be addressing this issue at the appropriate time, independent of (and above and beyond) the requirements stated in the AOC, since the AOC does not necessarily require secondary containment. Subsequently, and in accordance with the AOC, the Navy will be requesting regulatory approval of the currently recommended TUA decision to carry out BAPT upgrades to the Red Hill Facility without further delay.

### **Navy Detailed Response:**

1. As part of the 2019 TUA Decision Document, the Navy made the following commitment: “Navy/Defense Logistics Agency (DLA) will implement either “double-wall equivalency” secondary containment or remove fuel from Red Hill in approximately the 2045 time frame.” (DON 2019c, pg. 31).

The term “double-wall equivalency” is no longer used because “secondary containment” more accurately describes potentially viable BAPT that was not feasible when the Navy submitted the 2019 TUA Decision Document. Since submitting the TUA Decision Document, the Navy has researched secondary containment options and executed an agreement with Defense Innovation Unit (DIU) to determine the feasibility of applying existing commercial secondary containment technology to upgrade the Red Hill fuel tanks, as defined in HAR 11-280.1-24.

The technology that the Navy is evaluating includes the use of two new containment layers, and therefore would not rely upon the existing steel liners, unlike any of the double walled alternatives currently under review in this first BAPT cycle. The identified technology is used on tankers up to five times the size of the Red Hill tanks and is designed to withstand very harsh environments. The feasibility study is scheduled for completion in 2021, and the results of this effort will be included in the next TUA Decision Document.

If proven feasible, this solution would not rely on the existing steel liner for either containment or structural support. While investigation of the potential secondary containment solution appears promising, there is currently no practicable way to provide secondary containment measures to the Red Hill fuel tanks in the immediate future. Until such time secondary containment can be achieved, the layers of protection provided by the BAPT outlined in the 2019 TUA Decision Document are the best practicable measures currently available.

In reference to the definition of “double-wall equivalency” secondary containment, this RFI response will serve as an update to the 2019 TUA Decision Document:

TUA Decision Document, pages 6 and 13: Please delete the following item:

**4. “Double-Wall Equivalency” Secondary Containment or Removal of Fuel in the 2045 Time Frame**

*Navy/DLA will implement either “double-wall equivalency” secondary containment or remove fuel from Red Hill in approximately the 2045 time frame. Navy/DLA will determine the expected service life of the facility and evaluate alternate bulk fuel storage options. A*

*plan for placing the empty tanks in a strategic ready reserve status will also be developed for the event of wartime requirements.*

And replace it with:

#### **4. Secondary Containment or Removal of Fuel in the July 15, 2045 Time Frame**

*By July 15, 2045, Navy/DLA will implement secondary containment at Red Hill in accordance with the technical details defined in HAR 11-280.1-24. Fuel will be removed from any tanks that have not yet been upgraded by that time. Navy/DLA will determine the expected service life of the facility and evaluate alternate bulk fuel storage options. A plan for placing the empty tanks in a strategic ready reserve status will also be developed for the event of wartime requirements.*

TUA Decision Document, page 31: Please delete the following item:

*Navy/DLA will implement either “double-wall equivalency” secondary containment or remove fuel from Red Hill in approximately the 2045 time frame. Navy/DLA will determine the expected service life of the facility and evaluate alternate bulk fuel storage options. A plan for placing the empty tanks in a strategic ready reserve status will also be developed for the event of wartime requirements.*

And replace it with:

*By July 15, 2045, Navy/DLA will implement secondary containment at Red Hill. Fuel will be removed from any tanks that have not yet been upgraded by that time. Navy/DLA will determine the expected service life of the facility and evaluate alternate bulk fuel storage options. A plan for placing the empty tanks in a strategic ready reserve status will also be developed for the event of wartime requirements.*

Henceforth, the Navy’s definition of “secondary containment” will be identical to the technical definition of secondary containment design described in HAR 11-280.1-24. This definition will guide the Navy’s feasibility study and engineering assessment for the development of a secondary containment solution:

- §11-280.1-24 Secondary containment design.
  - (a) Secondary containment systems must be designed, constructed, and installed to:
    - (1) Contain regulated substances leaked from the primary containment until they are detected and removed;
    - (2) Prevent the release of regulated substances to the environment at any time during the operational life of the UST system; and
    - (3) Be checked for evidence of a release at least every thirty-one days.
  - (b) Double-walled tanks must be designed, constructed, and installed to:
    - (1) Contain a leak from any portion of the inner tank within the outer wall; and
    - (2) Detect the failure of the inner wall.
  - (c) External liners (including vaults) must be constructed, and installed to:

- (1) Contain one hundred percent of the capacity of the largest tank within its boundary;
  - (2) Prevent precipitation and groundwater intrusion from interfering with the ability to contain or detect a leak or release of regulated substances; and
  - (3) Completely surround the UST's to effectively prevent lateral and vertical migration of regulated substances.
2. The Navy is committed to the AOC and continues to work with the Regulatory Agencies to ensure all tanks have been updated with an approved BAPT by 2037. Each tank will be upgraded to the latest approved BAPT during its next scheduled Clean, Inspect, and Repair (CIR) process. Please refer to RFI 3 for the current CIR schedule. The commitment for secondary containment by July 15, 2045 was not intended to be a component of the BAPT described in the 2019 TUA Decision Document. It is an additional commitment above and beyond AOC requirements. Each BAPT has a 5-year term, and each new TUA Decision Document is expected to contain an improved BAPT. The Navy anticipates progress toward secondary containment BAPT as part of TUA Decision # 4 by the September 2037 AOC deadline. The Navy will implement and include secondary containment in a subsequent BAPT only when research and development efforts determine it is available and practicable.
  3. The operative phrase in Hawaii Underground Storage Tank Regulations Section 11-280.1-21(c) is *“or must utilize a design which the director determines is protective of human health and the environment.”* Based on the application of this regulation, the state's UST regulations do not specifically mandate secondary containment as the only option, but instead leaves the determination of what is acceptable to the director of DOH. The Navy's commitment for secondary containment by July 15, 2045 is unrelated to the HAR requirements, as the HAR does not necessarily require secondary containment for tanks such as those at the Red Hill Facility. The Navy recognizes the AOC and the HAR as independent authorities. The Navy recognizes the AOC and the HAR as independent authorities and is taking action to comply with both the BAPT deadline of 2037 and the HAR deadline of 2038. While the Navy fully intends to conform to all Hawaii State Underground Storage Tank regulations, the HAR will be addressed separately and not in conjunction with any of the respective AOC products.

## Response to RFI 6: Justification of the Selected Combination of Release Detection Systems

### Regulatory Agencies' Comment:

#### **Justification on the Selected Combination of Release Detection Systems is Required**

Release detection is a critical aspect of risk management at all underground storage tank facilities. The AOC requires the Navy and DLA to summarize their current release detection practices and investigate opportunities to improve their release detection practice to better the Red Hill Bulk Fuel Storage Facility's ability to operate in an environmentally protective manner. The Navy has proposed the following as their improved release detection system:

- Install permanent enhanced release detection equipment in order to have the ability to run as many tank tightness tests as desired. Currently the Facility is conducting tank tightness testing at a semiannual frequency.
- Install slots in stilling wells to improve precision of existing automatic tank gauging (ATG) system with automatic fuel handling equipment (AFHE).
- Conduct a real-time soil vapor monitoring pilot project.
- Continue to install additional groundwater monitoring wells.
- Continue environmental sampling—soil vapor, oil/water interface measurements, and groundwater samples.

Release detection methods should provide the earliest possible detection of a release in order to quickly implement mitigation (release response) measures and minimize impact to the environment. Thus, detection and mitigation of the release is preferred to be addressed before impact to groundwater. The Decision Document does not clearly describe release detection options explored and the basis for the selection of these collective systems.

### Navy Summary Response:

Recognizing the importance of release detection, the Navy has implemented a wide range of release detection systems while continuing to identify and investigate opportunities to improve those systems. The *New Release Detection Alternatives Report* (DON 2018a) includes detailed analyses of the process the Navy is using to identify, screen, evaluate, and select the best release detection system alternatives. The report includes an evaluation of existing practices and identifies an array of potential alternatives, screened for compatibility with the Red Hill Facility. The Navy subjected these alternatives to a series of evaluation field tests, and then graded and rated these against other alternatives in a comprehensive decision matrix. Based on this extensive research, the Navy selected the optimal systems for release detection. This proposed "system-of-systems" far exceeds any federal and state regulatory requirements, providing integrated layers of protection that provide the earliest possible detection of a release. As an added benefit, two technologies that provide continuous real-time monitoring have been identified by the Navy. One (installing permanent release detection systems in each active tank) is being implemented, and the other (implementing continuous SVM) is proposed for testing and

evaluation. These release detection systems are just part of the larger collection of systems that also work to prevent releases.

## **Navy Detailed Response:**

### **1 Release Detection Options Explored and Basis of Selection for the Proposed Release Detection Methods**

The Navy's ongoing efforts to improve its release detection systems included conducting a market survey in 2008 to research release detection systems that might be appropriate for use at the Red Hill Facility (reproduced as Appendix F of the *Current Fuel Release Monitoring Systems Report*) (DON 2016). The market survey evaluated potential release detection systems through development of a decision matrix that ranked such factors as third-party certification, sensitivity, compatibility, reliability, customer support, and installation constructability. Based on these analyses, the Navy implemented tank tightness testing at Red Hill in 2009, prior to any then-current underground storage tank (UST) regulatory requirements for the Red Hill tanks. The Navy's initial tank tightness testing program called for testing active tanks every other year. In 2014, the Navy increased testing to an annual basis and increased requirements to bi-annual testing in 2018. Each Navy-directed increase in testing requirements (including the current tank tightness testing regime) was implemented prior to or in excess of applicable federal or state regulatory requirements. Of even greater importance, every tank since the program began in 2009 has successfully passed each tank tightness test.

More recently, in 2018 the Navy completed the Red Hill Administrative Order on Consent (AOC) Statement of Work (SOW) Section 4.6: New Release Detection Alternatives Report (DON 2018a). This document included the Navy's detailed analyses of release detection system identification, screening, evaluation, and recommendations requested in this RFI. The alternatives report evaluated existing practices at the time and identified the range of potential alternatives, screened the potential alternatives for compatibility with the Red Hill Facility, and conducted detailed analyses of those alternatives retained for consideration. Additionally, the Navy conducted a series of evaluation field tests and developed a decision matrix grading and rating the various alternatives. Specifically, the *New Release Detection Alternatives Report* evaluated:

- Static release detection systems, including inventory control, manual gauging, automatic tank gauging, continuous in-tank release detection, tank tightness testing, statistical inventory reconciliation; and
- Dynamic release detection systems, including interstitial monitoring, tracer testing, vapor monitoring, and groundwater monitoring.

These potential alternatives include the types of potential release detection methods listed in the relevant federal and state regulations [40 CFR §280.252(d) (1); HAR §11-280.1-43(10)]. The report evaluated the alternatives and offered the rationale as to why some are not currently recommended for implementation at the Red Hill Facility. For example, interstitial monitoring, which can be an effective method at other sites, cannot currently be installed at the Facility. The Red Hill Facility operates single-wall tanks, which do not have an interstitial space. While

interstitial monitoring is not currently applicable, it might conceivably be recommended in the future if a secondary containment system, such as the one currently under initial evaluation, becomes practicable at the Red Hill Facility. Many of the other alternatives listed above did not on their own precisely meet the detailed regulatory criteria, several have been modified to suit the Facility and have been retained as backup release detection systems that complement and bolster the tank tightness testing. The report concluded that tank tightness testing was the appropriate method to meet the regulatory requirements for release detection. As discussed in Section 2, below, the Navy exceeds the regulatory requirements by doubling the frequency of tank tightness testing and by implementing six additional methods of release detection, the results of which corroborate that the tanks are tight. As also discussed below, the Navy continues to look for ways to improve the release prevention and detection system and has also begun the process to implement and evaluate two additional real-time release detection methods.

## **2 Summary of Proposed and Potential Future Release Detection Systems**

Based on the analyses described above, the *Tank Upgrade Alternatives and Release Detection Decision Document* (DON 2019c) recommends and describes the following systems of release detection methods.

1. Semiannual tank tightness testing
2. Fuel inventory monitoring with Automated Fuel Handling Equipment (AFHE)/Automatic Tank Gauging (ATG) for inventory management (supplemented by manual tank gauging)
3. Soil vapor monitoring (SVM)
4. Groundwater long-term monitoring
5. Daily visual inspections of accessible portions of each tank
6. Manual fuel inventory and reconciliation (including trend analyses)
7. Pipeline visual inspection

Cumulatively, these methods far exceed regulatory requirements and provide a redundant and overlapping system with various frequencies and types of analyses that provide layers of protection for release detection and prevention. As described in Sections 2.1 through 2.4 below, the first method—tank tightness testing—is the primary release detection method, which satisfies and exceeds federal and state regulatory requirements and has consistently confirmed that all active tanks are tight. Methods 2 through 4 successively add additional protection by evaluating potential indications of a release on a quarterly, monthly, and continuous real-time basis; methods 5 through 7 provide additional layers of protection for detecting and preventing the quantity of hypothetical future releases. Out of an abundance of caution, the Navy has already implemented or begun implementing all these processes, which the AOC Regulatory Agencies confirmed in general terms “seem appropriate” (EPA Region 9 and DOH 2020c).

In addition to these currently used methods recommended in the *Tank Upgrade Alternatives and Release Detection Decision Document* (DON 2019c), the Navy is also investigating two additional methods (which may bring the total number of release detection methods up to nine) of providing additional layers of protection by implementing or investigating the feasibility of:

1. Installing permanent release detection systems in each active tank
2. Implementing continuous SVM

Section 2.5 describes the real-time on-demand capability for release detection that the Navy is proceeding to install in the active tanks. Section 2.6 describes the Navy's plans to investigate the feasibility of continuous SVM.

The Navy has consistently maintained the goal of preventing the loss of any fuel into the environment, and has devoted significant investments toward achieving that goal. Even if an amount of fuel were small enough to pass through these multi-layered detection systems, environmental data and studies have shown that naturally occurring bacteria present in the soil and bedrock are capable of bioremediating the hydrocarbons to prevent any significant impacts to groundwater or human health. These natural processes are described in the AOC SOW Section 6.3 *Investigation and Remediation of Releases Report* (DON 2020b) and in the Response to RFI 12.

## **2.1 Semiannual Tank Tightness Testing**

Tank tightness testing satisfies the federal and state regulatory requirements for release detection and is therefore the primary (but not the only) release detection method employed at the Red Hill Facility. The Navy began tank tightness testing in 2009 as a Best Management Practice. In 2014, the Navy began conducting tank tightness testing annually to increase confidence that no releases to the environment were occurring. In 2018, Hawaii revised their UST regulations to require (among other things) release detection through annual tank tightness testing for tanks like those at the Red Hill Facility. The Navy was already compliant with the new state regulations before they were promulgated. In 2019, the Navy once again adopted testing at a level in excess of state requirements, by conducting tank tightness testing every 6 months. Without exception over 170 tests, every tank containing fuel has passed every tank tightness test since the testing began in 2009, confirming that the tanks are tight.

HAR §11-280.1-43(10)(A) lists tank tightness testing as an authorized method of release detection for field-constructed underground storage tanks, such as those at Red Hill. The tightness tests must be conducted annually and must satisfy a detection level of 0.5 gallons per hour. In updating the federal regulations, the Environmental Protection Agency (EPA) stated that tank tightness testing is one of the acceptable release detection methods that "are reasonable and will quickly detect releases" (80 Fed. Reg. 41595). Hawaii recently updated the state regulations to include the same tank tightness option and criterion for tanks, such as those at the Red Hill Facility. The Navy currently exceeds that requirement by conducting tank tightness testing every 6 months and meeting the detection level before certifying a tank as tight.

Tank tightness testing is accomplished by installing a mass measurement system into a fuel storage tank and monitoring the mass in the tank for a period of 24 hours. Mass is measured since volume can change with variations in temperature or pressure, whereas mass remains constant unless fuel is moved into or out of a tank. This test is then repeated four additional times to obtain test results for five (5) consecutive days. The data from the five (5) tests are then sent



to the U.S. mainland for statistical analysis to confirm tanks are in compliance with state requirements.

The tank tightness method used by the Navy has been certified by an independent third party, the National Working Group on Leak Detection Evaluations. This group, whose members include release detection experts from ten states and the EPA, conducts independent evaluations to ensure that tank tightness testing methods are performed in accordance with an acceptable release detection test method protocol and meet EPA and other applicable regulatory performance standards.

The particular tank tightness vendor technology recommended was chosen based on a series of tests that were conducted on Tank 9 at the Red Hill Facility, beginning in 2018. Three leading release detection system vendors were selected for participation, who submitted a total of six release detection methods for evaluation. Each vendor contributed either an existing technology or an alternative technology release detection system for evaluation at the Red Hill Facility (an existing technology was either previously used or currently available in the release detection system market; an alternative technology was in-development and not previously used, nor currently available, in the release detection system market). Testing involved an independent third-party testing company approved by the AOC Regulatory Agencies conducting a series of continuous releases (magnitude at or near 0.5 gallons per hour) at Tank 9 of alternating values unknown to the vendors. The three vendors used their release detection equipment simultaneously to measure the induced releases, and the vendors' reports of their findings were then compared. Evaluation of the release detection methods was based on EPA's *Standard Test Procedures for Evaluating Various Leak Detection Methods* (EPA 2019).

Four of the release detection systems could not meet the required minimum detectable release rate (MDLR) level or reliability criteria. Two methods (identified herein as Method 1 and Method 2) were determined to be effective because they met both the MDLR requirements and the 95% probability of detection reliability requirement. Method 1 had an MDLR of 0.294, and Method 2 had an MDLR of 0.333 (MBI 2020). The Method 1 system was chosen for implementation. The results of the evaluation are presented in the AOC SOW Section 4.6 *New Release Detection Alternatives Report* (DON 2018a). As previously described and further discussed in Section 2.5, the Navy is in the process of evaluating the use of this technology in every operational tank on a permanent basis. This will then allow for tank tightness testing to be conducted on an as needed basis to help evaluate potential release detection anomalies associated with various release detection systems.

## **2.2 Fuel Inventory Monitoring (AFHE/ATG)**

The Navy employs an ATG system in each of its 18 serviceable fuel storage tanks at the Red Hill Facility. The ATG system is a hybrid tank gauging system that combines traditional and hydrostatic tank gauging qualities to measure both mass and density. Each tank at the Red Hill Facility is fitted with a vertical array of temperature and pressure sensors that provide the data. The system records temperature and pressure from the sensors in ATG-mode, and the software converts these readings to the data used in the tank-level module of the AFHE system.

The ATG system is integrated with the overall AFHE control system at Red Hill. The combined AFGHE/ATG systems are used to perform inventory management. In its current configuration, the ATG system provides data to the tank level module of the AFHE system. The AFHE is an inventory control system, used to track the product inventory in the overall Red Hill Facility, in real time. The AFHE system is monitored 24 hours a day, 7 days a week throughout the year. As such, the system complements and improves upon the 6-month tank tightness testing frequency.

The ATG equipment installed in the Red Hill tanks contributes to the data collected and processed by the AFHE. The AFHE provides the level of accuracy needed for Red Hill Facility inventory control. Although the AFHE is not certified to meet all the regulatory requirements for release detection, the loss of fuel from a tank can be detected through the monitoring and trending of inventory measurements, and through unscheduled fuel movement (UFM) alarms. The system is therefore a continuous real-time release detection system that provides real-time evaluation of potential releases and corroborates the results of tank tightness testing.

ATGs on each of the Red Hill Facility tanks are calibrated at least once per year to an accuracy of 1/16 inch by comparison to manual monitoring data. The Navy also verifies ATG measurements after each fuel movement by manually gauging the tanks with a tape measure calibrated against a National Institute of Standards and Technology (NIST) traceable standard. Slotted stilling wells were installed in 2015 to improve the precision of manual tank gauging. Any discrepancies between the ATG measurements and manual gauging greater than 3/16 inch are investigated to identify potential releases. In addition, the Navy attempts to detect any UFM, including releases, from their fuel storage tank system by collecting and processing ATG data using the AFHE system. Naval Information Warfare Center administers the AFHE system, and Control Room Operators receive alerts of any potential UFM locally in the control room at the site. AFHE accounts for volumes that move through the fuel storage system using flow meters and ATG data combined with strapping charts. Under static conditions when there are no fuel transfers (conditions that prevail in the Red Hill tank system), AFHE generates a warning alarm any time there is an apparent net loss or gain of more than 1/2 inch of fuel (2,448 gallons) in one of the tanks, and a critical alarm for more than 3/4 inch (3,672 gallons). During scheduled fuel transfers, AFHE generates a warning alarm for more than 1 inch (4,896 gallons) and a critical alarm for more than 1.5 inches (7,344 gallons). The Response to RFI 11 describes how alarms are investigated.

**Greater Detail of the Fuel Terminal Inventory System.** The Red Hill Facility manages petroleum, oil, and lubricant (POL) inventories in accordance with the Defense Logistics Agency (DLA) Energy P-7 *Accountability and Custodial Responsibilities for Defense Working Capital Fund Inventory and Government Property* (DLA 2019) for compliance controls and policy guidelines. This includes but is not limited to inventory accountability (daily, weekly, and end-of month reporting, and end-of-year inventory closeouts), managing a gain and loss control and analysis program, and overseeing inventory trend analysis on all POL products. While the Red Hill Facility maintains compliance with DOH and U.S. Coast Guard requirements, the Facility also follows regulations set forth by DLA Energy to provide timely and accurate reporting of all fuel transactions, inventories, and sales. All fuel inventories are managed in the AFHE down to a

1/16-inch accuracy. A Control Room Operator continuously operates the AFHE system and views POL inventories 24 hours a day, 7 days a week throughout the year.

The Fuel Management Enterprise Suite is a server-based application used by Defense Fuel Support Point (DFSP), including the Red Hill Facility, for inventory management and daily accounting of DLA Energy fuel transactions. The suite includes multiple client- and web-based applications used to manage all aspects of the DFSP fuel handling operations.

While maintaining accurate inventories of POL products, other tools are available that allow for a deep dive into analyzing book inventories and daily transactions. Inventory trend analysis is the management and oversight of gains and losses, and those are monitored for excessive gains or losses during the reporting period. Inventory trend analysis compares current and past inventories, either daily or monthly, to ensure that the POL products are managed accurately and more precisely, and it allows for causative research or investigation if necessary. Causative research takes into consideration the following items: accounting records, research errors, missing paperwork, transactions incorrectly processed, tank release tests, system pressure tests, ATG calibration/certification, tank strapping chart certification, and receipts. The Terminal Manager then reviews the causative research and determines if the response is acceptable; if not, the causative research is elevated to a higher authority. All inventories are reconciled at the end of the month and year and require reporting to DLA Energy for auditing purposes and to verify that all Defense Wide Working Capital Fund fuel is properly accounted for and managed by the Responsible Officer.

Per DLA Energy P-7, the ATG equipment transmits level, density, and temperature data back to the Accountable Property System of Record, where the strapping data are stored and the look-up/interpolation takes place.

ATGs that used to receive energy products from an external source (commercial contractor or another DFSP) are required to be properly verified for accuracy. Red Hill Facility operators will perform and document on DLA Form 2026 a minimum of three manual gauging comparisons at a single level at least once per month using a tape and dip stick. If the variation exceeds  $\pm 4$  millimeters (3/16 inch), the DFSP performs further investigation. However, the Control Room Operator and the Responsible Officer monitor daily, weekly, and monthly inventories down to 1/16 inch for accuracy. If there is variation between the ATG and manual gauging, once the ATG is out of calibration by  $\pm 4$  millimeters (3/16 inch), a trouble ticket is submitted to the DLA Energy Help Desk for the system to be recalibrated. The investigation commences by recording three consecutive manual measurements, then calculating the arithmetic average via the DLA Form 2026, ATG Verification for Inventory Control. In the context of this document, "three consecutive readings" means that the user makes three individual hand gauge readings (drying off the tape each time) while measuring the tank in question. It must be done with the tank in a static condition (no fuel flowing in or out). When the arithmetic average of the three readings is within the stated variation, then the investigation is complete. If the arithmetic average of the three readings is greater than the stated variation, two additional manual gauge readings are made, totaling five, and the arithmetic average is calculated from those five readings.

All the inventory control measures described above allow for redundancy and the proper tracking and investigation, if needed, of all POL inventories to ensure the system-of-systems works together to further ensure all fuel and POL products are accounted for at all times.

### 2.3 Soil Vapor Monitoring

Another complementary release detection method used at Red Hill is SVM. Since 2008, the Navy has measured soil vapor concentrations of volatile organic compounds under all the Facility's active fuel storage tanks on a monthly basis. As described in more detail in the Responses to RFIs 9 and 10, a network of 50 sensors is installed under the 18 active fuel storage tanks (two to three sensors under each tank) (see RFI 9 Figure 1). The SVM system is intended primarily to provide a line of evidence for release detection in support of other release detection technologies currently in place. In combination with other data, the system has also helped advance the understanding of petroleum fate and transport (including the weathering of residual fuels held in the vadose zone) at the site.

The monthly SVM sampling provides an additional layer of protection (which may be upgraded to continuous soil vapor monitoring if pilot testing proves successful) relative to the other methods used for release detection. The monthly sampling helps ensure that the Facility is protective of groundwater and the environment. Results of the Navy's SVM following the 2014 Tank 5 release demonstrate that SVM provides a robust system for detecting a release and is an important layer of protection that supplements other release detection methodologies. The SVM data are compared to criteria established in the Red Hill *Groundwater Protection Plan* (DON 2014) and updated by the AOC Regulatory Agencies in 2016 (EPA Region 9 and DOH 2016). The Navy reports all results to DOH in monthly Soil Vapor Monitoring Reports that are published on DOH's Red Hill web pages and available to the public.<sup>6</sup> An exceedance of the criterion initiates contingency actions in accordance with the *Groundwater Protection Plan*. In addition, the Navy has used its analysis of SVM results following the 2014 Tank 5 Release to improve its monitoring program so that vapor concentrations can be more reliably evaluated.

Using the results of the monthly monitoring, the Navy has been evaluating both the maximum concentration criteria approved by the AOC Regulatory Agencies and the use of concentration trends. Based on an observed time lag between the January 2014 Tank 5 release and the maximum concentrations detected by SVM underneath the tank, the Navy has recommended reducing the concentration criteria by 42% and 82% for the two types of fuels that the Red Hill tanks currently store to enable much quicker detection of a potential fuel release, which would result in significantly more stringent criteria for follow-on action. However, the concentration trend analyses currently conducted have consistently produced "false-positive" results that are not indicative of actual releases, which has the potential to reduce the effectiveness of the system. Therefore, to maintain reliability in the results and consistency of responses, the Navy does not recommend continuing the trend analyses as currently implemented. Trend analysis may,

<sup>6</sup> <https://health.hawaii.gov/shwb/ust-red-hill-project-main/>

however, be effective if a continuous monitoring system can be established. SVM concentration criteria and trends are further discussed in the Response to RFI 9.

In addition, as described in Section 2.6 below, the Navy is currently exploring improving the SVM system further by potentially implementing a continuous, real-time monitoring system across the Red Hill Facility to provide much more rapid release detection, as described in the Response to RFI 10.

## 2.4 Groundwater Long-Term Monitoring

The Navy established the Red Hill groundwater monitoring network in 2005 with five monitoring locations, expanded to eight at the time of the 2014 Tank 5 Release. The Navy has since added an additional 14 single and multilevel wells for a total of 22 groundwater monitoring locations today, as shown on RFI 6 Figure 1. Groundwater monitoring includes both measuring for the potential presence of fuel product in the wells near the tanks (which has never been present in any measurable quantity) and collecting groundwater samples for laboratory analyses. Groundwater monitoring is currently conducted four times a year on a quarterly basis, which complements and improves upon the 6-month tank tightness testing frequency. Groundwater monitoring also serves as a means to ensure that if potential continuous small releases (or large releases), which the data do not suggest are ongoing, were to otherwise escape detection and impact groundwater, they would be detected.

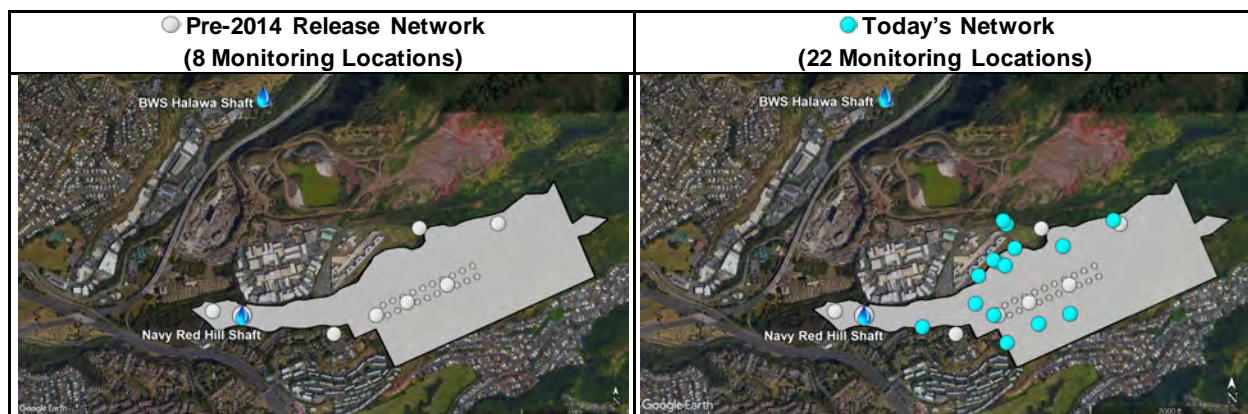

RFI 6 Figure 1: Red Hill Groundwater Monitoring Network Before and After the 2014 Tank 5 Release

In accordance with the DOH-approved *Groundwater Protection Plan* (DON 2014), the Navy conducts groundwater monitoring events at all network locations quarterly at a minimum. The groundwater samples are analyzed by a nationally accredited laboratory and validated by an independent data validator. The Navy closely evaluates all the validated results for data quality, current trends and anomalies, and indications of natural attenuation. The results are provided to DOH in *Quarterly Groundwater Monitoring Reports* that DOH publishes on their Red Hill project webpages, where they are available for public review.<sup>7</sup>

<sup>7</sup> <https://health.hawaii.gov/shwb/ust-red-hill-project-main/>

The groundwater monitoring results are also integral to the Navy's environmental work under the AOC. Installation of each new well provides valuable data about the subsurface (geology, hydrogeology, and water-level measurements) that increase understanding of both the impacts of past fuel releases, groundwater flow, and contaminant fate and transport in the Red Hill area. As shown on RFI 6 Figure 2, the Navy plans to further expand the groundwater monitoring network, and field crews are currently drilling new groundwater monitoring wells and collecting new data.

The Navy uses two different methods within the layers of protection to monitor groundwater: sample and analyze the groundwater in the Red Hill area for chemicals of concern, and inspect the surface of the aquifer directly below the Red Hill Facility to confirm there is no petroleum floating on the surface of the aquifer:

- As previously described, all Red Hill groundwater monitoring wells are currently sampled at least once each quarter to evaluate various chemicals and other constituents that have been agreed to with the AOC Regulatory Agencies.
- Another way the Navy monitors the groundwater to confirm there is no evidence of actual fuel product on the groundwater surface is by inspecting the surface of the aquifer in the monitoring wells (the density of fuel is less than that of water, so fuel floats on the surface of water). All conventional wells in the network are checked at least quarterly as part of the quarterly groundwater monitoring events, and the four monitoring wells closest to the tanks (RHMW01, RHMW02, RHMW03, and RHMW05) are checked at least every month (depending on available access). This "product gauging" has been conducted regularly since 2008, and no measurable thickness of petroleum product has ever been detected in any groundwater monitoring well.

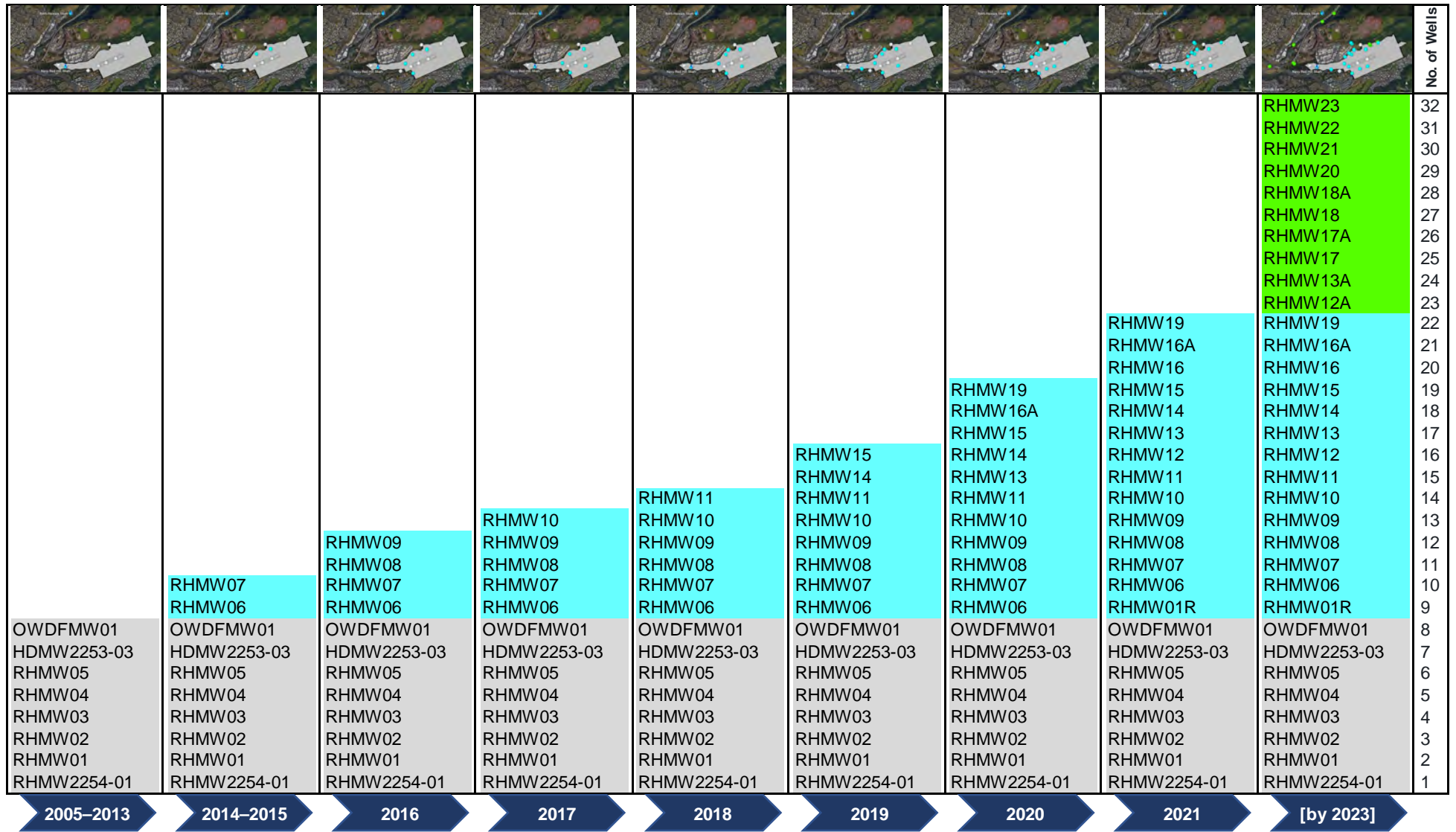

**Key dates:**

January 2014: Tank 5 Release  
 September 2015: Red Hill AOC signed

- Planned Monitoring Well (location and installation date subject to change)
- Post-2014 Tank 5 Release (2015–2021)
- Pre-2014 Tank 5 Release (2005–2014)

Note: Some existing and planned wells are collocated “paired” wells (adjacent shallow and deep wells).

**RFI 6 Figure 2: Expansion of the Red Hill Groundwater Monitoring Well Network Following the 2014 Tank 5 Release**

The Navy continues to expand its Red Hill groundwater monitoring network. From five wells that were being used before the 2014 Tank 5 Release to 20 wells in operation today, the current plans are to increase that number to 30 wells by 2023 (RFI 6 Figure 2). Due to the significant depth to groundwater, the complicated drilling in this heterogeneous basaltic environment, and the limited number of on-island contractors (only one) with the equipment capable of performing this complicated drilling, each well takes significant time, care and expense to install. As new basal groundwater monitoring wells come online, they are added to the quarterly groundwater monitoring events, with results reported to DOH and made available to the public on at least a quarterly basis. Not only will the additional data help document the safety of the drinking water supply, the geologic and hydrogeologic data collected during well drilling and installation will also greatly expand the understanding of subsurface conditions across Halawa Valley. The Navy will incorporate the additional data to perform future groundwater modeling efforts, establish a formal groundwater monitoring network under the AOC SOW Section 7.3, and update the Red Hill *Groundwater Protection Plan* (DON 2014).

Future improvements to the groundwater monitoring network's ability to detect hypothetical large releases will include the establishment of sentinel wells which is an expansion to the current monitoring well network. As follow-on work to the AOC SOW contaminant fate and transport modeling and as documented in its AOC SOW Section 7 *Sentinel Well Network Development Plan* (DON 2017b), the Navy will establish a formal Red Hill monitoring well network to identify possible releases to groundwater and potential contaminant migration and thus protect drinking water through the use of improved regular groundwater monitoring. This network will include any additional sentinel wells in accordance with the AOC SOW and the objectives of the *Sentinel Well Network Development Plan* (DON 2017b). The network will be described in a Groundwater Monitoring Well Network Report and subsequently formalized in a Groundwater Monitoring Well Network Decision Document. Both documents will require AOC Regulatory Agency approval. The Navy will then incorporate the approved network into its update of the Red Hill *Groundwater Protection Plan* (DON 2014), which will also provide additional long-term protection beyond that required by Hawaii's UST regulations.

Another related layer of protection for detection of hypothetical future large releases, as the Navy continues to protect of the drinking water supply systems, is the regular collection and analysis of samples of public drinking water provided by the Honolulu Board of Water Supply (BWS) and Naval Facilities Engineering Systems Command (NAVFAC), Hawaii, the results of which are published in annual drinking water quality reports known as Consumer Confidence Reports. These reports have always confirmed that the water from all three drinking water supply wells closest to the Red Hill Facility (i.e., BWS Halawa Shaft, BWS Moanalua Wells, and Navy Red Hill Shaft) has historically been and remains safe to drink. As a result of the 2014 Tank 5 release, DOH developed and implemented a plan to closely monitor the drinking water from the Navy's Red Hill Shaft. Drinking water from Red Hill Shaft is now required to be sampled and analyzed at least quarterly, and is currently conducted on a monthly basis. As part of this enhanced program, water samples are taken both pre- and post-chlorination to ensure that drinking water is safe to drink and has not been impacted by fuel constituents.



## **2.5 Installing Permanent Release Detection Systems in Each Active Tank**

As described in the Response to RFI 1, the Navy is currently planning to install permanent tank tightness testing equipment in all Red Hill tanks containing fuel. Subject to EPA and DOH approval, the Navy plans to begin installing this equipment in fall of this year (2021). Permanent installation of this equipment will provide the capability of on-demand tank tightness testing. This will provide an important additional step to verify potential releases detected by any of the other release detection systems and will further reduce the likelihood of a small chronic release going undetected.

## **2.6 Continuous Soil Vapor Monitoring**

The monthly monitoring of soil vapor described in Section 2.3 involves a field crew collecting and measuring soil vapor sample concentrations with a photoionization detector (PID). To improve its release detection capability and thus protection of the groundwater resource, the Navy is exploring installing an automated system that *continuously* measures soil vapor concentrations with sensors that can immediately alert Red Hill Facility operators if a response action to be taken is required. To determine if such a system can be installed Facility-wide, the Navy will first test the system at three fuel storage tanks to evaluate its feasibility, effectiveness, and reliability. The pilot test is being developed in coordination with the AOC Regulatory Agencies and, once approved, is anticipated to take 6–12 months. An outline of the Navy's plan is currently being reviewed by the AOC Regulatory Agencies. Details of this effort are further described in the Response to RFI 10.

This page intentionally left blank

## Response to RFI 7: Integration of Release Detection Systems

### **Regulatory Agencies' Comment:**

#### **Greater Detail on the Integration of Release Detection Systems is Needed**

The Decision Document should clearly describe how the new enhanced release detection will be implemented and integrated with the other release detection systems (inventory and soil vapor monitoring). This should include specifics on monitoring hardware, data collection, and operations. The proposal should also describe the performance goals of the system and how this new system, along with other existing and proposed systems that provide indications of a suspected release, will be used as multiple lines of evidence in an overall release detection and response system, and comply with UST regulations.

Similarly, the inventory monitoring system is a critical component of the Release Detection at the Facility, the Decision Document should include greater detail that describes the improvements to the inventory system, its performance goals and how this improved system will be integrated with the overall release detection and response system.

In addition, the Navy should explain how vapor monitoring will be used as another line of evidence for release detection, which the Regulatory Agencies believe is more sensitive than inventory monitoring and can be used more frequently than precision static tightness testing.

The frequency of precision release detection tests (tank tightness tests) and the basis for this frequency need to be clearly defined and justified in the Decision Document. Higher frequency will result in a greater degree of risk mitigation; however, in order to conduct a precision test, the tank being tested needs to be isolated to insure an accurate test. This testing interrupts normal operations, so the Navy needs to evaluate the trade-off between frequency and operations to justify proposed frequency. Additionally, the Decision Document also needs to clearly describe the types of conditions or indications that would require additional precision testing (for example, in response to alarms and when soil vapor measurements show an increasing trend). UST regulations require all suspected releases to be confirmed within seven days. Investigations and confirmation require a system test (tanks and piping tightness test) or another procedure approved by the Department of Health.

The Decision Document should present clear release detection and response decision trees that establish inspectable and auditable records of release detection system alarms or other indications of a suspected release. This should include the details of causative research that is triggered with alarm, actionable thresholds or unusual operating conditions. The decision tree should describe what actions are automatic versus what actions rely on the judgement of specialized operators. The Decision Document should describe how data indicating suspected and confirmed releases will be shared with the regulatory implementing agency (DOH). The proposed decision should analyze the timeline for providing this information to the implementing

agency and clearly describe the causative research (tests) completed as timely as possible, including an option for real-time alarm reporting.

### **Navy Summary Response:**

The proposed “system-of-systems” for release detection contains built-in redundancies and overlapping methods, data sources, and frequencies of analyses that are designed to detect any hypothetical release. The seven existing release detection systems include: automated fuel inventory monitoring; daily visual inspections of each tank; manual fuel inventories reconciliation; semiannual tank tightness testing; soil vapor monitoring; groundwater monitoring; and tank and pipeline visual inspection. Integration of these systems is described in the Detailed Response, below. Several of these systems are currently being evaluated for potentially significant upgrades. The Navy has developed procedures for responding to and documenting investigations into indications of potential releases and continues to comply with all applicable notification requirements. In addition to the seven existing systems, two potential additional release detection systems are described below (one of which is planned for implementation and the other of which will soon undergo a pilot test). These additional systems are expected to greatly improve the cumulative effectiveness of the systems and provide on-demand capabilities for detection and verification.

### **Navy Detailed Response:**

#### **1 The Red Hill Facility’s System of Release Detection Systems Provides Multiple Checkpoints and Layers of Protection**

The Red Hill Facility employs a “system-of-systems” that provides layers of protection for the prevention, detection, and mitigation of a fuel release to ensure the continued protection of human health and the environment. The Response to RFI 6 describes each independent release detection system, which, combined with this Response to RFI 7, are proposed to include:

1. Semiannual tank tightness testing
2. Fuel inventory monitoring with Automated Fuel Handling Equipment (AFHE)/Automatic Tank Gauging (ATG) for inventory management (supplemented by manual tank gauging)
3. Soil vapor monitoring (SVM)
4. Groundwater long-term monitoring
5. Daily visual inspections of accessible portions of each tank
6. Manual fuel inventory and reconciliation (including trend analyses)
7. Pipeline visual inspection
8. Installing new permanent release detection systems in each active tank

In addition, a feasibility study is planned to evaluate the potential use of:

9. Continuous soil vapor monitoring (CSVM)

As described below, these independent but overlapping systems operate in an integrated fashion to monitor all available release detection information, with varying frequency. These systems can

be used to provide independent checks of data from the other systems to provide layers of protection for release detection and minimization. Various aspects of causative research that can be conducted based upon these release detection systems are further described in Responses to RFIs 6, 7, 8, 9, and 10.

- **Tank Tightness Testing.** As described in the Response to RFI 6, tank tightness tests are the first line of defense that completely satisfy applicable release detection requirements. Importantly, the tank tightness program has consistently shown, since implementation in 2008, that all Red Hill tanks that contain fuel have been tight. Because tank tightness testing is conducted at twice the minimum frequency required by the regulations and meets the requirements in the Red Hill Administrative Order on Consent (AOC) Statement of Work (SOW) Section 4.1, this system alone exceeds applicable requirements. Nevertheless, the Navy has implemented and continues to implement additional systems to provide additional resolution on both temporal and quantitative scales, as described in the following.
- **The AFHE/ATG System.** As described in the Response to RFI 6, one of the primary additional means of release detection is the use of the AFHE/ATG system to track daily inventories, levels, and quantities of the fuel in each tank. The AFHE/ATG system provides a continual record of fuel inventories and movement that can be used to respond to, validate, or trigger implementation of other release detection measures. These measures and systems provide safeguards in the form of redundancy and allow for the proper tracking and investigation of all Petroleum, Oil, and Lubricant (POL) inventories to ensure the system-of-systems work together to ensure that all fuel and POL products are accounted for at all times.
- **Soil Vapor Monitoring.** SVM has been proven to be effective for responding to releases, and in its current monthly implementation, it provides significantly better temporal resolution that improves upon the biannual tank tightness testing. Like the AFHE/ATG system, SVM can initiate causal analysis of potential releases and can also be part of the causal analysis when other systems are alerted. Although data are normally gathered in the field, samples from the SVM system can be shipped for laboratory analysis to investigate whether vapors are from recent or older potential releases. As discussed below, the SVM system is proposed to be evaluated for further significant improvements.
- **Groundwater Monitoring.** Groundwater monitoring is an effective tool to both track the natural attenuation of historical releases and provide an independent check as to whether there is evidence of a release large enough to reach groundwater. Groundwater monitoring events are normally conducted quarterly, and as such provide long-term data indicating that large releases are not occurring. However, as was demonstrated in 2014, groundwater monitoring can be used on a more frequent basis as an important tool to help verify that small or moderate releases do not impact the groundwater and the drinking water resource. As discussed in the Response to RFI 6, the Navy has significantly increased and improved upon the groundwater monitoring network and continues to do so.
- **Daily Visual Inspections.** All the accessible portions of tanks and pipelines at the Red Hill Facility are inspected. This method of confirming other release detection systems was effective in confirming the 2014 Release and could be effective at detecting certain types of hypothetical future releases, including many of those identified in the AOC SOW Section 8

Quantitative Risk and Vulnerability Assessment [QRVA] Phase 1 report (DON 2018c) as primary contributors to potential risk.

- **Manual Fuel Inventory and Trend Analyses.** Manual fuel inventory and trend analyses are additional measures to respond to potential triggering events that come from the other release detection systems, helping to verify data from the AFHE/ATG system and conduct causative research, as discussed below.
- **Planned Permanent Release Detection Systems.** Pending AOC Regulatory Agency concurrence, the Navy has conducted feasibility analyses and intends to install permanent release detection systems in each active tank. These systems would be extremely valuable and provide the full-time on-demand capability to verify the results or implications of all the other release detection methods.
- **Potential CSVM.** Should the technology prove feasible after planned testing (see Response to RFI 10), the ability to conduct CSVM may provide a new benchmark system of release detection data, which would be continually viewable by operators in the Control Room. Identification and testing of this potential solution reflect the Navy's commitment to improving all aspects of Red Hill Facility operations.

All these measures and release detection systems provide redundant safeguards and allow for the proper tracking and investigation of all POL inventories to ensure that the detection measures in the system-of-systems work together to ensure that all fuel and POL products are accounted for at all times and that any hypothetical future releases are identified, minimized, and responded to in the quickest practicable fashion. The following sections describe how these systems are integrated and implemented.

## **2 Responses to AFHE/ATG Indications, Including During Return to Service**

The Event Sequence Diagrams (ESDs) presented on RFI 7 Figure 1 describe steps taken when a release detection system indicates the possibility of a release. The diagrams illustrate two scenarios: the first would occur if the tank was initially idle (or "static") when the AFHE system indicates the possibility of a release; the second would occur if a fuel movement (i.e., issue, receipt or inter-tank transfer) was in process when the AFHE system indicates the possibility of a release. The ESDs show that detection of the release could be delayed if the tank was not static, because the AFHE system is not as effective at detecting changes during a fuel movement. The AFHE system can more rapidly detect a release an hour or two after the fuel movement has ended and the tank settles, if sufficient volume has been lost from the tank to initiate an AFHE low-level warning alarm. The Response to RFI 11 calculates potential losses during the relatively brief delay under various scenarios.

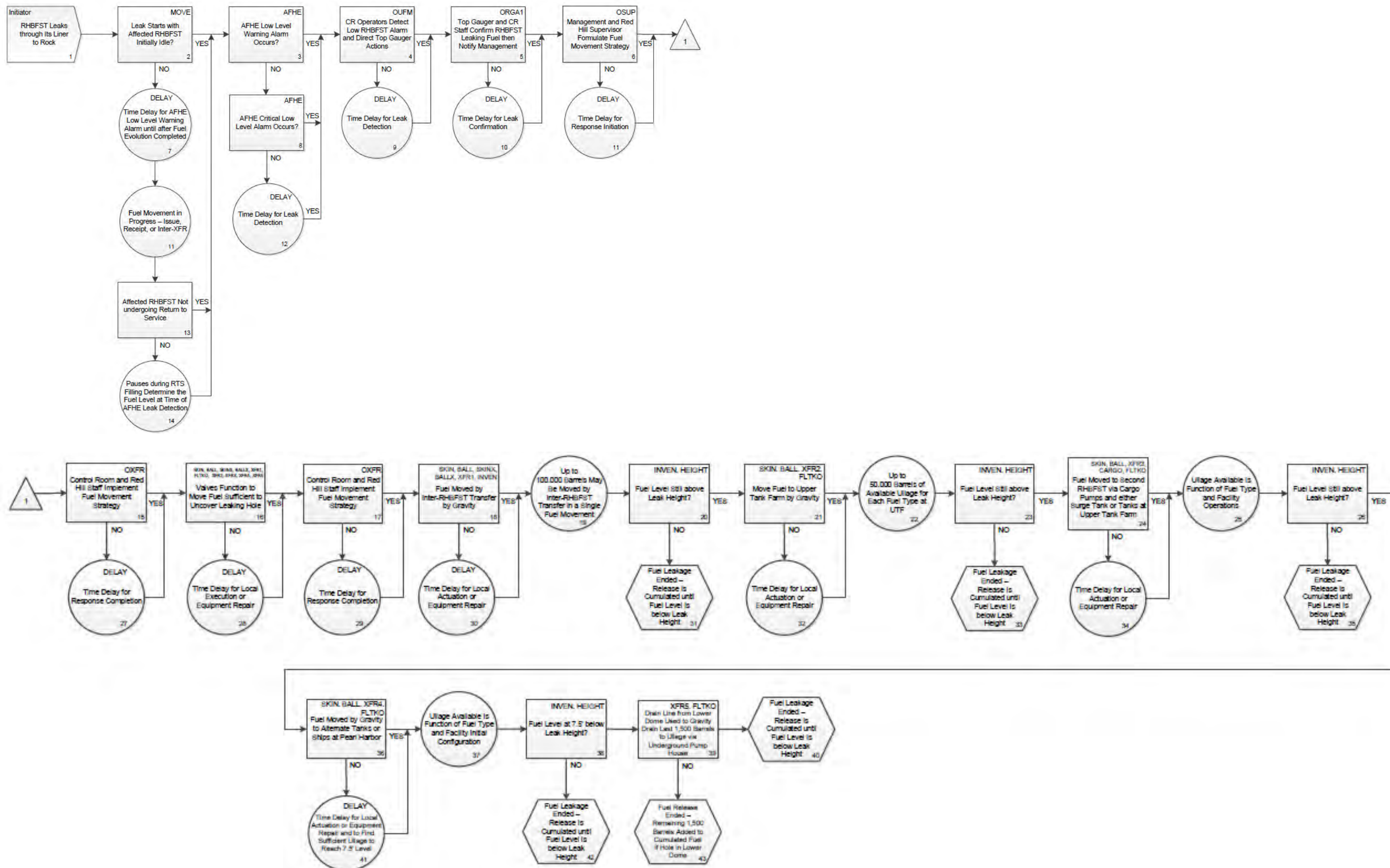

RFI 7 Figure 1: Event Sequence Diagram for Tank Releases Directly to Rock

This page intentionally left blank



The filling process for returning a Red Hill tank to service was significantly improved after 2014 to include up to ten pauses, each of which is maintained for approximately 48 hours, rather than filling the tank in one or two receipts as was often done previously. This significantly improves the ability to detect, identify, and respond to a potential release while filling the tank, which is a scenario the QRVA Phase 1 report described as important to managing risk (DON 2018c). In earlier years at the Red Hill Facility, records indicate that when a release was detected and some fuel was removed, the operators would stop the emptying process before fully emptying the leaking tank to identify where the tank level continued to drop. Such checks were completed to confirm elevations in the tank where releases were occurring. This practice is no longer used at Red Hill because the tank would need to be emptied to repair a hole, regardless of the location.

A release could be detected manually by the Control Room Operator immediately after the conclusion of a fuel movement by observing changes in AFHE level readings. However, operators conduct manual tank gauging to confirm a release has occurred. If an AFHE low-level, warning, or critical alarm occurs, procedures require operators to confirm the levels in the AFHE by conducting one or more manual tank gaugings. The operators are also required to conduct manual gauging within 2 hours of concluding a fuel movement. As part of this procedure, both AFHE indication and confirmation by manual tank gauging are required to confirm that fuel level is decreasing in a tank before further action is required. The Responsible Officer also verifies all fuel inventories in volume and levels on a daily, weekly, and monthly basis. This provides a level of redundancy for confirming levels observed by the Control Room Operator in the AFHE system.

If a release were to be confirmed, management and the Red Hill Operations Supervisor would be notified immediately. The Red Hill Operations Supervisor would then oversee the response using operators and staff. Typically, and for this ESD, the initial response involves promptly determining the quickest method to remove fuel from the suspected tank. This requires opening the skin valve and all other ball valves in alignment of the suspected tank and transferring fuel to other tanks with available ullage (i.e., available storage capacity). Tanks with available ullage can include other Red Hill tanks, Upper Tank Farm tanks, surge tanks, Hickam Field storage tanks, or ships. The Red Hill staff must manually operate valves and cargo pumps as necessary to transfer fuel out of the suspect tank. The idea is not to isolate the release, but to transfer fuel out of the suspect tank before it is released. Delays at any step along the way can postpone the response. Once the fuel level in the tank is reduced below the hole in the tank, further release stops.

The volume of fuel released in a hypothetical scenario would be a function of many variables, including the release rate, initial fuel level, elevation of the hole in the tank, time to remove fuel from the tank, rate at which the tank is emptied, and any delays experienced during the response.

The last event on RFI 7 Figure 1 is a variety of actions and fuel movements that may be chosen or are necessary to affect the tank being emptied. The lower panel of RFI 7 Figure 1 begins when operators are tasked to implement the supervisor's strategy to empty the tank. Although depending on the level of the hole, the leaking tank may not have to be fully emptied to uncover the hole, the operational training is to empty the tank in its entirety.

Five approaches are commonly used to empty a tank. As presented on RFI 7 Figure 1 (lower panel), these include:

- XFR1 – Inter-tank Transfer by Gravity
- XFR2 – Move Fuel to Upper Tank Farm by Gravity
- XFR3 – Cyclically Move Fuel to Another Tank Using Cargo Pumps and Surge Tanks or via the Upper Tank Farm
- XFR4 – Move Fuel by Gravity to Alternate Tanks or Ships at Pearl Harbor
- XFR5 – Drain the Last 7.5 Feet of Fuel from the Lower Dome Using the Fuel Lines to the Underground Pump House

Not all these approaches may be necessary to empty a tank depending on the initial height of the fuel. During the 2014 Tank 5 release, only XFR1, XFR2, XFR3, and XFR5 were used to empty the tank; XFR4 was not used. There are no specific priorities for implementing these approaches. It is likely, however, that XFR1 and XFR2 are the most common approaches to use. Inter-tank transfers by gravity or transferring to ullage in the Upper Tank Farm at Pearl Harbor are not only a rapid way to move fuel but also most effective when the faulty tank is initially at its highest fuel level. Using cargo pumps to move fuel to other tanks of the same fuel type allows one to take advantage of the available ullage in other tanks.

XFR5 involves draining the final 7.5 feet of fuel. The nozzle between the tank penetration and the first isolation valve in the lower access tunnel extends approximately 7.5 feet above the bottom of the tank. This pipe cannot be used to empty the bottom 7.5 feet of fuel. Instead, a gravity drain is connected to the main fuel line to remove the final estimated 1,500 barrels or 61,500 gallons of fuel.

### **3. Responses to Indications of Potential Overfills**

Another hypothetical possibility identified by the AOC SOW Section 8 QRVA Phase 1 report (DON 2018c) is the potential for overfills (fuel levels in a tank above a specified alarm level). Although the system has automatic protections that prevent overfills, in the highly unlikely event of an overfill, the ESD for tank release resulting from overfilling a tank and being released from a hole above the maximum operating level is presented on RFI 7 Figure 2 (upper panel). This ESD was developed based on the Facility operational guidance provided by Red Hill standard operating procedures and on responses to questions posed to Red Hill operations staff. RFI 11 Figures 1 and 2 provide a graphical depiction of the range of alarms and associated levels in various tanks.

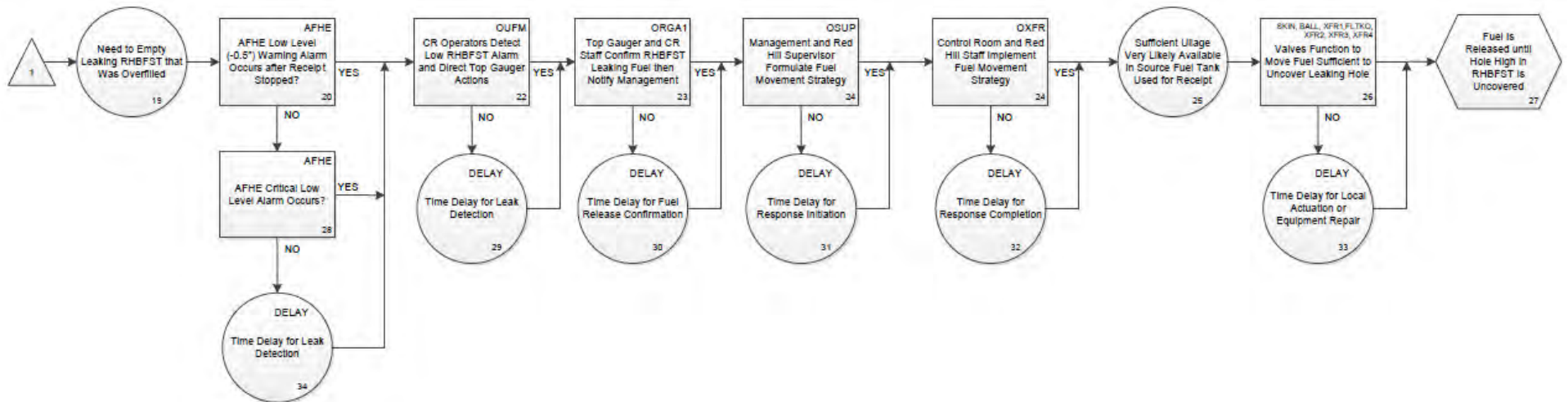
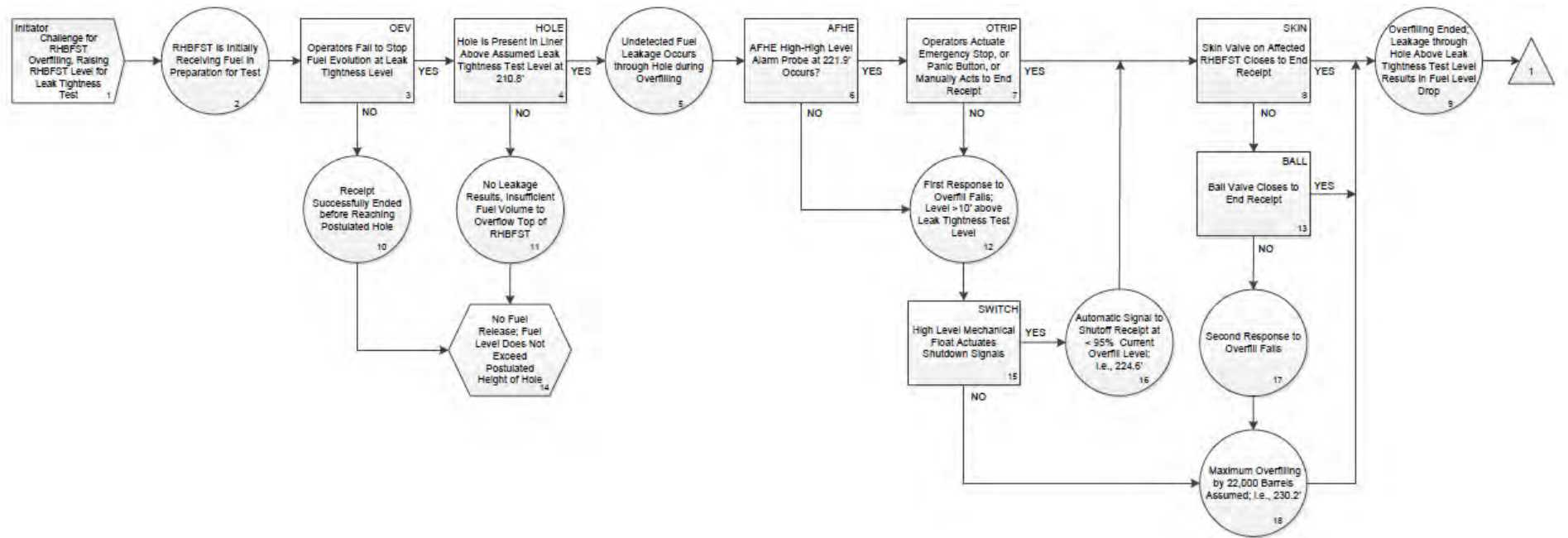

RFI 7 Figure 2: Event Sequence Diagram for Releases Resulting from Overfilling a Tank

RFI 7 Figure 2 indicates the response to a scenario in which fuel was being transferred to a tank to fill it to its maximum operating level in preparation for its annual tank tightness when an overflow occurred. This hypothetical scenario would require an error by the Control Room Operator using cargo pumps to transfer fuel into the tank from the underground pump house, as well as failure of a second operator responsible for monitoring the level and volume transferred out of the source tank. If filling continued above the maximum operating level, this ESD scenario questions whether there is a through hole in the tank steel liner above the maximum operating level. If not, the sequence terminates with no release of fuel. There is also a large ventilation shaft at the top of the upper dome in each tank. However, overfilling by the amount of fuel needed to reach this level at the peak of the upper dome would require additional failures and is even more unlikely. It would require an extra 6,500 barrels or 266,500 gallons to reach the upper dome opening, above the inventory needed to raise the level to 212 feet where the worst-case scenario for a hole in the steel liner occurs. This would require fuel movement to continue for at least an additional 2 hours beyond the intended stopping point, assuming fuel is transferred at 2,500 barrels per hour.

At a fuel level of 221.9 feet, more than 10 feet above the maximum operating level (still below the expansion ring), a high-high level alarm sounds in the Control Room. The Control Room Operator can use an emergency stop or panic button to stop the cargo pumps and isolate the tank being filled. If the overfilling does continue due to equipment malfunction, a high-high level alarm mechanical switch located inside the tank is triggered to signal the tank skin valve to close and stop all operating cargo pumps. Either of these actions will terminate transfer of fuel before level reaches 224.6 feet, still 15 feet below the top of the upper dome.

The ESD scenario further assumes the skin or ball valve fails to close to terminate the transfer of fuel into the tank. Stopping the cargo pumps would also terminate the fuel transfer. However, the scenario further assumes the interlock to stop the pumps also fails. This scenario is conservative and extremely unlikely because the skin and ball valves are also redundant. These valves are rebuilt and tested when each tank undergoes the Clean, Inspect, and Repair (CIR) process.

Once overfilling ends, the lower panel of RFI 7 Figure 2 begins. This scenario assumes the hole in the tank is located just slightly above the maximum operating level at 212 feet. Fuel above 212 feet may be released while overfilling continues during the period it takes to identify a simultaneous drop in fuel level and empty the tank below the elevation of the hole in the tank.

RFI 7 Figure 2 (lower panel) considers the response of the AFHE low-level warning alarm after tank settling and a decrease in level of 0.5 inch. This is the first indication to the Control Room Operator that the tank was overfilled and a release from the tank was occurring. As with any fuel movement, after a 2-hour tank settling period following a fuel movement, the operator would conduct manual tank gauging before the low-level warning alarm occurs. Once the release is confirmed, the sequence of actions and events in the ESD is similar to that of a direct release.

If a release is confirmed, management and the Red Hill Operations Supervisor are notified immediately. The Red Hill Operations Supervisor then oversees the response using operators and staff and the same process that is described above under “Responses to AFHE/ATG Indications.”

The main difference between the release scenario and the tank overfilling scenario is that it's highly likely sufficient ullage could be readily identified during an overfilling scenario by simply returning fuel to the source tank. Furthermore, any release could be quickly isolated by reducing the fuel level below the elevation of the hole in the faulty tank. This would theoretically require transferring only a small portion of the total volume out of the tank.

Again, the volume of fuel released is a function of many variables, including the release rate, initial fuel level, elevation of the hole in the tank, time to remove fuel from the tank, rate at which the tank is emptied, and any delays experienced during the response.

The last stochastic event of RFI 7 Figure 2 shows a variety of actions and fuel movements that may be chosen or are necessary to impact the tank being emptied.

#### **4 Unscheduled Fuel Movement Causative Research**

The Response to RFI 11 provides details on the investigation of indications of possible releases from the release detection systems (referred to as "causative research") as well as response actions under various hypothetical scenarios. Operators can identify releases by analyzing the release detection system data and reports, as well as Red Hill Facility Unscheduled Fuel Movement (UFM) reports. The computerized inventory control system at the Red Hill Facility automatically generates UFM alarms. Facility operators and supervisors then conduct causative research to confirm a release of fuel based on the estimated volumes of fuel associated with individual UFM reports as well as their experience and judgment, which may include using other release detection systems. UFM reports are subjected to root cause analysis and associated corrective action is formulated and implemented. The UFM reports and associated fuel inventory control and history records are reviewed, evaluated, and analyzed to develop a reasonable estimate of fuel release from chronic release scenarios.

An example of a UFM report is shown on RFI 7 Figure 3.

### UFM REPORT

<b>Background:</b>	EXAMPLE: At (time), on (Day of the week), December 25, 2015, Red Hill tank 0110 had a UFM			
<b>Action:</b>	At (time) placed the tank into an evolution to remove the alarm			
	At (time) the Red Hill Rover checked lower and upper tunnels (all Conditions were normal or the following problems were found)			
	At (time) the Red Hill rover top gauged tank 0110			
	The comparison from the last top gauge is 01/16"			
<b>Cause:</b>	I believe the AFHE computer for tank 0110 may need calibration or to be reset. Tank 0110 dropped down to 207'-09-15/16". The tank is still in an evolution for AFHE fuel level movement and for monitoring. Also, the BS&W has risen from 0'-00-00" to 05'-07-05/16". The BS&W level alarm has been activated on AFHE for tank 0110.			
<b>Top Gauge of Tank 0110:</b>				
	<b>Date:</b>	<b>Time:</b>	<b>Top Gauge</b>	<b>Rover Name</b>
<b>Previous:</b>	20-Dec-15	4:00 PM	211'-08-06/16"	
<b>Current:</b>	25-Dec-15	5:20 AM	211'-08-06/16"	
<b>Originator and Review:</b>				
				<b>Name</b>
<b>Created by:</b>	Concur/Do Not Concur			
<b>Bulk Supervisor:</b>	Concur/Do Not Concur			
<b>Fuel Operation Supervisor:</b>	Concur/Do Not Concur			
<b>Deputy Director:</b>	Concur/Do Not Concur			
<b>Director:</b>	Concur/Do Not Concur			

End (1)

**RFI 7 Figure 3: Example Unscheduled Fuel Movement (UFM) Report**

## 5 Confirmed Fuel Release Reporting

All release response actions and reporting follow the regulations set forth by the *Red Hill Fuel Storage Facility (RHFSF) Response Plan* (Appendix B) and the Hawaii Department of Health, State Administrative Rules, Underground Storage Tank, Chapter 11-280.1, Subchapter 6, Release Response Action (effective January 17, 2020).<sup>8</sup> The notification requirements and timelines for a confirmed release are summarized in RFI 7 Table 1.

<sup>8</sup> <https://health.hawaii.gov/shwb/files/2020/01/11-280.1-Jauary-17-2020-Standard-format-with-summary-and-signature-pages.pdf>

**RFI 7 Table 1: Confirmed Release Notification Requirements and Timelines**

<b>Confirmed Release</b>	
Telephone notice to Department of Health	Within 24 hours
Written Confirmed Release Notice (CRN)	Within 7 days
Initial abatement report	Within 20 days of confirmed release
Initial free product removal activities	Within 30 days of confirmed release
Initial site assessment	Within 45 days of confirmed release

An example of a Confirmed Release Notification Form required by DOH within seven (7) days of a confirmed release is shown on RFI 7 Figure 4.

STATE USE ONLY		
Facility ID:	Release ID:	Date Received:
GENERAL INFORMATION AND INSTRUCTIONS		
<p><b>This form should be completed immediately and only after reporting a confirmed release by telephone within 24-hours to the Hawaii's DOH US 1 Section.</b> Completion of this notice will serve to fulfill part of the notification requirements of HAR 11-280.1-61. Please type or print in ink all items except "Signatures" in Section III. This form must be completed for <b>each US 1 release occurrence.</b> Completed form must be mailed to: Department of Health, Solid and Hazardous Branch, 2827 Waimano Home Road #100, Pearl City, Hawaii 96782</p>		
I. REPORTING PARTY AND FACILITY INFORMATION		
24-Hour Reporting Party Name, Title, Affiliation:		Phone Number:
Facility Name & Address:		
Facility Contact Person, Affiliation, & Address:		
Landowner Name, Affiliation & Address:	Lessor Name, Affiliation & Address:	Lessee Name, Affiliation & Address:
E-mail address:	E-mail address:	E-mail address:
Phone Number ( )	Phone Number ( )	Phone Number ( )
II. RELEASE INFORMATION (Circle all that apply in Items A-I)		
<b>A. Source of the Release:</b> Piping Tank(s) Overfill Dispenser Submersive Turbine Delivery Problems # "Tank(s)" list tank sizes:		
<b>B. Cause of the Release:</b> Spill Overfill Physical / Mechanical Damage Corrosion Installation Problem Other (Specify):		
<b>C. Method of Discovery &amp; Confirmation:</b> Closure Monthly Release Detection Tightness Test Site Check Other (Specify):		
<b>D. Estimated Quantity of Substance Released:</b> _____ Gallons _____ Unknown		
<b>E. Type of Substance Released:</b> Unloaded Gas Loaded Gas Diesel Used or Waste Oil Hazardous Substance Other (Specify):		
<b>F. Immediate Hazards:</b> Explosion Fire Vapor Exposure Recoverable Free Product Drinking Water Threat Other (Specify):		
<b>G. Release Impact:</b> Surface Water Ground Water Soil Air		
<b>H. Migration Pathways:</b> None Utility Conduits Subsurface Drains Sewer Lines Unknown Other (Specify):		
<b>I. Actions Taken:</b> Evacuated Nearby Area Removed UST Contents Recovered Free Product Excavated Soils Ground Water Recovery Other (Specify):		
III. UST OWNER OR OPERATOR CERTIFICATION (Read and sign after completing all sections to the extent possible)		
I certify under penalty of law that I have examined and am familiar with the information submitted in this notice, and that based upon my inquiry of those individuals immediately responsible for obtaining the information, I believe that the submitted information is true and accurate.		
Name, Title, & Company:		
Signature:		Date:
DOH Form CRN (2018)		

**RFI 7 Figure 4: Example Confirmed Release Notification Form**

## **6 Red Hill Facility Response Plan**

The *RHFSF Response Plan* (CNRH 2020) (Appendix B) describes response actions in the hypothetical event of a release. The *Response Plan* is a detailed oil spill response plan approved by Commander, Navy Region Hawaii. This response plan meets all regulatory requirements of the Oil Pollution Act of 1990. All operators and watch-standers at the Red Hill Facility are trained in oil spill response on an annual basis using both classroom and field training. The field training allows the operators to be well-versed in responding to a small, medium, or large fuel spill simulated in a training environment, and to effectively respond to an actual emergency.

The Red Hill *Response Plan* outlines necessary critical actions to respond to a fuel release. These actions include notifying the Chain of Command and federal and state regulatory agencies (consistent with regulatory requirements) as well as activating a spill response contractor to assist with oil spill response and cleanup. The oil spill response strategies vary from a small, medium, large, to catastrophic release. Operators and watch-standers are primarily responsible for identifying an active fuel release and notifying management. The Control Room Operator takes the next steps necessary to confirm, mitigate, and stop the release. Supervisors then coordinate the overall efforts of the oil spill response.



## Response to RFI 8: Effectiveness of Improvements to the Release Detection Systems

### **Regulatory Agencies' Comment:**

#### **Effectiveness of the Improvements to the Overall Release Detection System Should be Quantified**

The Decision Document should describe the effectiveness of the integrated system. For example, describe how the integrated release detection system affects precision and accuracy and how they will be used to reduce thresholds for alarms and action triggers, such as in unscheduled fuel movement alarm thresholds. This discussion should include any limitations on the system such as limitations during transient conditions after a fuel movement and limitations caused by the unique hemispherical tank bottom.

### **Navy Summary Response:**

The Navy plans to continue improving the current system of release detection systems, which is currently far more expansive than the applicable requirements in the federal and state underground storage tank (UST) regulations, and the minimum release detection requirements agreed upon in the Administrative Order on Consent (AOC). First, pending regulatory approval, the Navy plans to permanently install tank tightness testing equipment in all Red Hill tanks containing fuel. Permanent tank tightness testing equipment would allow facility operations to conduct on-demand tank tightness testing. This capability can bolster the effectiveness of the other release detection systems; it also allows for longer tightness testing periods, which, in turn, can potentially achieve improved detection rates of lower amounts. In addition, the Navy proposes conducting a pilot test for continuous soil vapor monitoring, which would also increase overall system effectiveness, in part by providing real-time feedback to control room operators. These improvements would further increase the overall effectiveness, sensitivity, and reliability of the integrated release detection system.

### **Navy Detailed Response:**

#### **Permanent Integrated Release Detection System**

As discussed in the Responses to RFIs 6 and 7, the Navy has proposed that a permanent integrated release detection system be installed in each active fuel storage tank at the Red Hill Facility. The integrated system would give the Navy the ability to monitor all active fuel storage tanks on a semi-continuous and on-demand basis and increase the overall capability of monitoring for unscheduled fuel movements (UFMs). Should any other of the release detection systems indicate data anomalies or potential releases, system operators could immediately run tests using the integrated release detection system. Additionally, detection levels less than 0.5 gallons per hour (gph) may be achievable if the test is run for a longer period on a tank that is either in or is put into static mode. The integrated release detection system operated under such conditions will allow for a high degree of precision and accuracy. This would also be used to

reduce or verify thresholds for alarms and action triggers such as in UFM alarm thresholds and associated investigation and response activities. The system will also allow for enhancement of data gathering activities to confirm that the tanks remain tight.

As part of system implementation, the Navy will have a contractor on site or available within a 2-hour period for technical expertise, oversight, and troubleshooting of the permanent release detection system. The system will be able to detect small chronic releases (which current data do not indicate are ongoing), resulting in more timely responses with minimal risk of product loss.

One limitation of the system is that release detection must be performed when the tank is static after intentional fuel transfers are completed. If an unauthorized movement of fuel is suspected, an upgrade of the system would allow a tank tightness test to be generated internally, eliminating the need to mobilize a contractor off-site or off-island, reducing delay and time lost to complete the test. Essentially, unscheduled fuel movements will be caught earlier and allow for verification of a UFM in a much shorter time following indications of a potential release. This will allow managers and operators to be more proactive and respond quickly without a time delay and/or dependency on a contractor to mobilize to the site.

The permanent release detection system will supplement and bolster the system of release detection systems currently in place. For example, the Navy will continue to conduct bi-annual tank tightness testing to document compliance with regulatory requirements. The current thresholds for alarms, action triggers, and UFM alarm thresholds will be used until data are gathered and implemented on the permanent system. The permanent release detection system will be integrated into causative research required from other release detection methods and will have the ability to reduce certain alarms, action triggers, and UFM alarm thresholds, improving the overall system. The reduced thresholds will be evaluated and implemented with regulatory concurrence.

### **Continuous Soil Vapor Monitoring**

As described in the Response to RFI 10, the Navy also proposes conducting a pilot test to evaluate converting the existing soil vapor monitoring system, which has proven to be effective, into a continuous soil vapor monitoring (CSVM) system. If feasible and implemented, this new system would provide an additional readout of real-time data available to the Control Room Operator on a permanent basis. By analyzing these data, operators will be able to detect a release that escapes detection by the other systems, while providing data that corroborate information from the other release detection systems. The data could also potentially provide the capability for further analyses of ongoing natural attenuation processes in the subsurface. If feasible, the CSVM system is expected to be integrated into the permanent release detection system.

## Response to RFI 9: Concentration Criteria and Trend Analysis for Soil Vapor Monitoring

### Regulatory Agencies' Comment:

#### **Explanation of New Soil Vapor Concentration Thresholds and Basis to Discontinue Trend Evaluation is Needed**

The Navy proposes to continue monthly soil vapor monitoring (SVM), but with reduced soil vapor thresholds from 280,000 parts per billion of volatile organic compounds by volume (ppbv) to 50,000 ppbv for tanks with jet fuel and from 14,000 ppbv to 8,000 ppbv for tanks with marine diesel. Based on the 2014 release, the Regulatory Agencies agree that the existing 280,000 ppbv action level is too high and needs revision; however, the selection of the new values and how they will be used to trigger action requires further discussion.

Page 23 of the TUA Decision Document states, "*The existing protocols for evaluation of soil gas monitoring events uses a concentration trend methodology to trigger causative research.*" The document does not define what "causative research" entails. The document further states, "*In addition, the 2014 release from Tank 5 was detected as part of inventory control reconciliation. The leak would not have been detected for several months using only the trend-based soil gas monitoring. Use of the 50,000 and 8,000 ppb thresholds for jet fuel and diesel fuel, respectively, would have allowed the release to be detected sooner and independent of inventory control measures. Based on 10 years of monitoring, the concentration trend evaluations do not appear to be useful for identification of possible fuel releases, and therefore will be discontinued.*"

The Regulatory Agencies agree that soil vapor monitoring with improvements can potentially provide early detection of a release. For example, on December 9, 2013, Tank 5 refill operations started. On December 23, 2013, routine SVM showed a four to five-times increase in soil vapor levels in SV-5M and SV-5D (the middle and deep probes) in comparison to the average of the previous six months' data. On December 10, 2013, the first Unscheduled Fuel Movement (UFM) alarm went off. From January 13 -17, 2014 the tank was drained. On January 15, 2014 and January 31, 2014 SVM levels were as much as 350 times higher than the December 23, 2013 results. Therefore, SVM can provide another line of evidence of a release, and if done more frequently, could be more sensitive than inventory monitoring.

However, it is unclear why concentration trend evaluation will be discontinued. The Navy, in the Decision Document should explain the basis for this change. Rather than a fixed action level (thresholds), it appears that comparison of soil vapor measurements for a specific probe to the statistical background concentration for the specific probe that accounts for variations in existing conditions, similar to a concentration trend evaluation, would better account for the varying environmental conditions surrounding each probe (porosity, historical fuel release) that could impact the data and its interpretation. Then, similar to the description in the Decision Document, any detection above a statistically significant increase would trigger the collection of a soil vapor sample to determine whether the detected vapor is fresh or weathered. An onsite gas

chromatography/mass spectrometry unit could expedite results and associated release response actions, as needed.

In addition, based on the Navy's review of data collected since 2005, DOH observations of the current SVM program, and upon discussions with the Navy's contracting Officer Technical Representative, we believe that current data collection can be improved. While a detailed discussion of the deficiencies in the current monitoring program is outside of the scope of this letter, the rehabilitation of inoperable probes and implementation of a better quality assurance protocol will reduce random and systematic sampling and analytical errors.

### **Navy Summary Response:**

The Navy has conducted monthly SVM events under Red Hill's 18 active fuel storage tanks as a method of detecting a fuel release since 2008 to help ensure the Facility is protective of groundwater and the environment. Results of the Navy's SVM following the 2014 Tank 5 release demonstrate that SVM provides a robust and effective system for detecting a release, and the Navy is currently exploring implementing a continuous, real-time monitoring system across the Red Hill Facility to provide much more rapid release detection. SVM provides an important layer of protection that supplements other release detection methodologies.

Historically, the SVM data have been used in two distinct ways: (1) by directly comparing the actual measured data to concentration criteria approved by the Regulators; and (2) by estimating apparent concentration trends based on four monthly data points for each soil vapor monitoring point (SVMP). Analyses of over 12 years of monthly monitoring data show that the first method, comparing the actual data to the soil vapor concentration criteria, is a robust and effective method of release detection, but the second method, estimating concentration trends based on monthly data, is less useful. Moreover, based on statistical analyses of the concentration data, the Navy recommends implementing even more stringent concentration criteria that will further improve the system. Based on an observed time lag between the Tank 5 release and the maximum concentrations detected by SVM underneath the tank, the Navy recommends reducing the concentration levels by 42% and 82% for the two types of fuels that the Red Hill tanks currently store, to enable much quicker detection of a potential fuel release.

However, while the comparison of actual data from the SVM system to the concentration criteria is a robust and effective release detection method, the concentration trend analyses procedure as currently implemented is less effective and not recommend for continued use. The current trend analysis procedure evaluates trends based on four data points collected over the course of four monthly monitoring results for each SVMP and assuming a statistically significant linear trend. This procedure may not reflect actual trends at any given point in time and results in causative analysis for at least one SVMP during most monthly monitoring events, when no statistically significant trend is likely occurring. These apparent trends are not indicative of actual releases and are not sustained over longer periods. Rather, the calculated trends simply reflect normal month-to-month variations in photoionization detector (PID) readings.

The analysis of over 12 years of historical data indicates that the combined changes of implementing more stringent (reduced) concentration criteria levels and discontinuing the current trend analysis procedure will improve leak detection. While the current method of trend estimation based on monthly data has not proven effective, analyses of actual trends may be effective in the future if a continuous monitoring system can be established, because a continuous monitoring system will provide near real-time data that may enable analyses of actual concentration trends.

**Navy Detailed Response:**

**Overview of Soil Vapor Monitoring Program**

Since 2008, the Navy has measured soil vapor concentrations of volatile organic compounds under all the Red Hill Facility's active fuel storage tanks on a monthly basis. The network of 50 SVMPs installed by the Navy includes 2 to 3 probes installed at a shallow angle below each of the 18 active fuel tanks (RFI 9 Figure 1). The SVM system is intended primarily to provide an additional line of evidence for release detection that bolsters the other release detection technologies currently in place. In combination with other data, the system has also helped advance the understanding of petroleum fate and transport at the site, including the weathering of residual fuels held in the vadose zone.

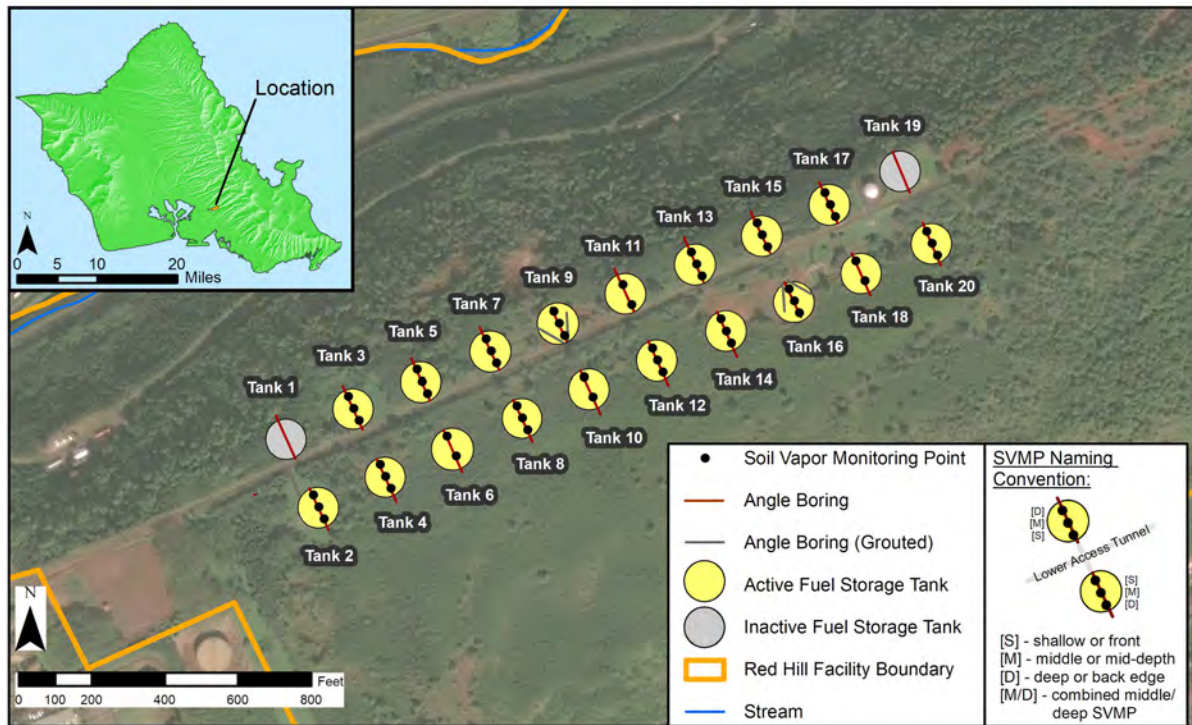

Notes: Soil Vapor Monitoring Program:

- Two to three SVMPs are installed below each active fuel storage tank.
- Every month, the petroleum vapor concentrations are measured at each monitoring point using a photoionization detector (PID), a hand-held instrument commonly used to measure vapor concentrations.
- If measured concentrations exceed a defined criterion or estimated trends increase over time, the Red Hill Facility operators take additional measures to investigate whether there may have been a possible fuel release.

**RFI 9 Figure 1: Soil Vapor Monitoring Network Underneath the Red Hill Fuel Storage Tanks**

The SVM system is an indicator, similar to the check engine light on a vehicle, to notify the operator of a potential issue that should be further assessed. The SVM data are compared to the indicator level or criteria established in the Red Hill *Groundwater Protection Plan* (GWPP) (DON 2014). The Navy reports all results to DOH in monthly Soil Vapor Monitoring Reports, which are published on DOH's Red Hill webpages. An exceedance of a concentration criterion initiates contingency actions in accordance with the GWPP. In addition, the Navy has used its analysis of SVM results following the 2014 Tank 5 Release to improve its monitoring program so that concentrations can be more reliably evaluated. As shown on RFI 9 Figure 2, monitoring results related to the 2014 Tank 5 Release demonstrate that SVM provides a robust system for detecting a release. Improvements to the system have the potential to further improve its sensitivity and effectiveness.

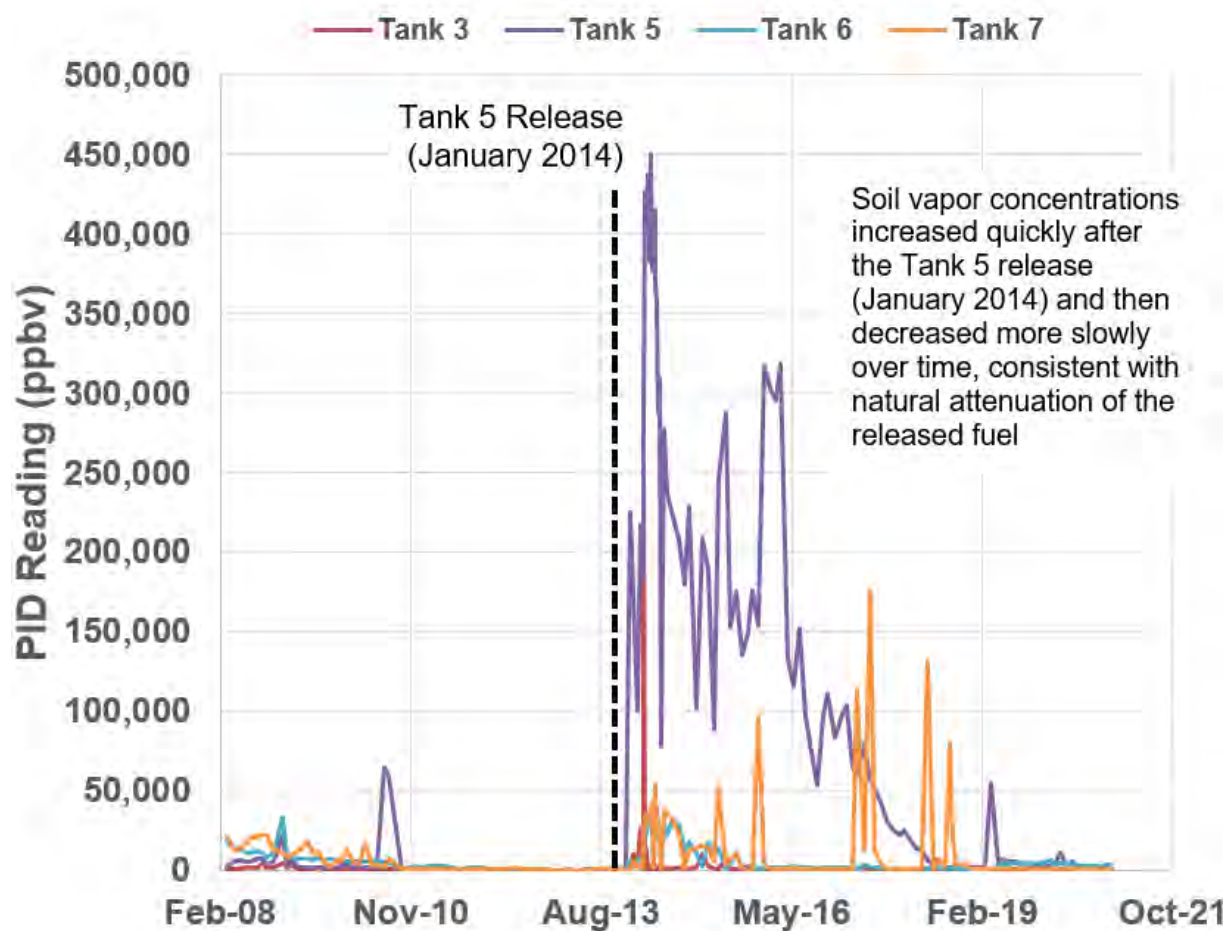

**RFI 9 Figure 2: Soil Vapor Response Under Tank 5 After the January 2014 Release**

As described in RFI 10, the Navy is currently exploring the feasibility of conducting real-time continuous soil vapor monitoring (CSVM) via a pilot test as one of several systems to enhance release detection capability. A CSVM system would provide real-time information on potential releases and can be used to supplement other release detection technologies, including Automated Fuel Handling Equipment/Automated Tank Gauging (AFHE/ATG) and tank tightness

testing. The intent of the CSVM pilot test is to evaluate the feasibility of a full-scale CSVM system for all tanks (i.e., evaluate the performance of the pilot monitoring equipment in terms of accuracy, precision, and sensitivity). In addition, the monitoring results from the pilot test will be used to understand the range of baseline PID readings, to understand the effect of Red Hill Facility operations and other factors on these baseline readings, and to define preliminary concentration criteria and concentration trend criteria appropriate for causative response for a full-scale CSVM system. Until a Facility-wide CSVM program can be implemented, the monthly SVM program will continue as discussed below (and may potentially incorporate updates based on discussions with regulatory experts, if appropriate). If implemented at full scale, the Navy anticipates CSVM will both be more sensitive than the current monthly SVM program (i.e., would be able to detect smaller releases) and provide more rapid release detection.

Historically, monthly PID readings have been evaluated in two distinct ways: (1) by directly comparing the actual measurements to the concentration criteria (i.e., 280,000 parts per billion by volume [ppbv] of volatile organic compounds for tanks with Jet Fuel and 14,000 ppbv for tanks with Marine Diesel); and (2) by estimating apparent concentration trends based upon assumed linear trends calculated from the previous 4 months of monitoring results for each SVMP. The linear trend estimation based on monthly measurements, however, is not necessarily indicative of actual trends at any point in time. If the linear trend line indicates an average concentration increase of greater than 20 ppbv per day, then the concentration trend is classified as “strongly increasing.” This criterion was chosen as an indicator but is not based upon any statistically significant parameter. After each monthly monitoring event, the trend analysis is updated. If this trend estimation identifies any SVMPs with a “strongly increasing” concentration, then the Navy Fleet Logistics Center is notified, initiating a “causative research” response.

For each individual tank with either (1) a PID reading above the concentration criterion or (2) a “strongly increasing” estimated trend, the causative research response includes the following actions:

- Review maintenance and repair contractor records for reports of any factors that could have influenced increasing trends.
- Review Inventory Trend Analysis Reports.
- Review tank tightness testing records and confirm that all active tanks have passed.
- Inspect areas surrounding all tanks for evidence of a release or spill.
- Conduct visual inspection of the tunnel areas in the vicinity of the tank.

While the comparison of the actual data to the concentration criteria is a robust and effective release detection method, the estimation of apparent concentration trends based on monthly data is less effective and yields a classification of “strongly increasing” for one or more SVMPs during most monthly monitoring events. Based on more than 12 years of monitoring records, these so-called “strongly increasing” concentration trends are not indicative of actual releases but simply reflect normal month-to-month variations in PID readings. However, each identification of a “strongly increasing” concentration trend criterion has initiated a “causative research” response. This “causative research” conducted in response to a “strongly increasing” concentration trend has never yielded supporting evidence of a fuel release (with the exception of the Tank 5 release,

which was more effectively detected by comparing the actual measured data to the concentration criteria). Therefore, based on 12 years of monthly SVM investigations, the Navy recommends implementing more stringent (i.e., lower) concentration criteria and discontinuing the current concentration trend analysis procedure. The data indicate that these two changes will improve leak detection while streamlining the monitoring program by reducing the “causative research” responses due to concentration trend classifications that have proven not to be associated with leaks. In addition, as part of the continuous monitoring pilot test, the Navy will evaluate whether a new trend analysis methodology may be useful in the future when actual rather than estimated trends can be established using near real time data that may be generated by the continuous monitoring system.

### **Concentration Criteria**

Use of soil vapor concentration criteria is a robust, effective, and reliable release detection method. As acknowledged by EPA and DOH, the existing concentration criteria are relatively high. Based on recent evaluations of existing SVM data from March 2008 to December 2020, the Navy recommends revising (significantly lowering) the concentration criteria. The more stringent revised concentration criteria are greater than the PID readings commonly observed during periods of normal Facility operations and are below than the PID readings recorded immediately after the 2014 Tank 5 release. Therefore, the revised concentration criteria will support rapid leak detection while minimizing the number of false-positive results and the associated unnecessary causative research.

The new concentration criteria are based on an empirical review of the monthly PID monitoring results from March 2008 to December 2020. This data set covers 168 monitoring events (i.e., a “monitoring event” is the measurement of SVMPs on a single day). Most of these monitoring events were conducted monthly, during which all accessible SVMPs were sampled; however, some more-frequent monitoring events that were conducted immediately following the 2014 Tank 5 release covered only the SVMPs at Tank 5 and nearby tanks. The evaluated data set includes over 7,300 individual SVMP soil vapor measurements. The empirical review of this large data set indicated that a concentration criterion of 50,000 ppbv for tanks with Jet Fuel appears to be an appropriate level between background levels and elevated vapor concentrations potentially associated with a tank release. Excluding Tank 5, there were only nine cases where a tank SVMP exhibited a PID reading above 50,000 ppbv between 2008 and 2020 (RFI 9 Figure 3). One was at Tank 3 (274,000 ppbv) shortly after the Tank 5 release, and the other eight (53,000–176,000 ppbv) were at Tank 7. During one monthly monitoring event, two SVMPs at Tank 7 exhibited readings above 50,000 ppbv; therefore, excluding Tank 5, readings above 50,000 ppbv have been recorded during eight separate monitoring events in the period evaluated. While the elevated reading at Tank 3 appears to be attributable to the Tank 5 release, the cause(s) of the elevated reading at Tank 7 have not been determined. These elevated readings have been transient (i.e., have not persisted across multiple consecutive monthly monitoring events), suggesting that they are not associated with a sustained fuel release. Based on these historical results, although soil vapor concentrations could exceed 50,000 ppbv when an actual release has not occurred, the frequency of these false-positives would be few, thus ensuring reliability of the release detection system. In 2019, the Standard Operating Procedure for the monthly monitoring



program was modified to specify immediate collection of a vapor sample for offsite laboratory analysis from any SVMP with a PID reading above 50,000 ppbv.

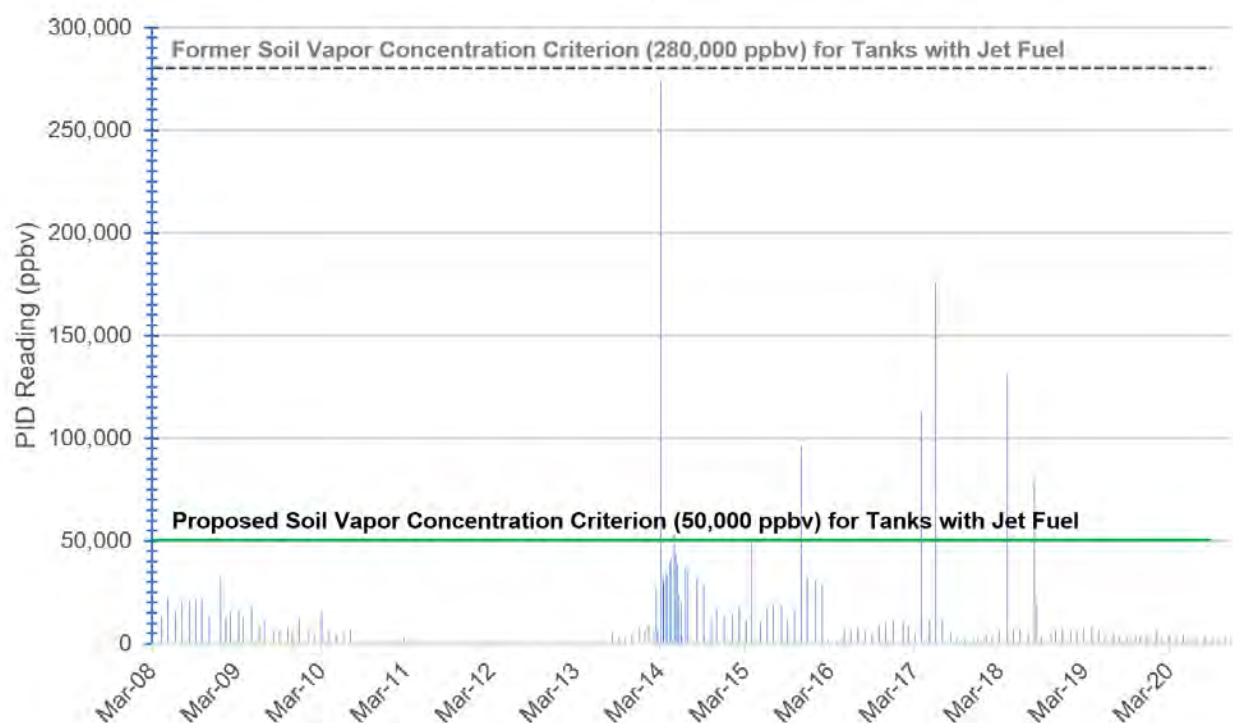

**RFI 9 Figure 3: Maximum PID Reading (Excluding Tank 5) for Each Monitoring Event, March 2008 – December 2020**

At Tank 5, the PID readings of 225,000 ppbv at SV05M and 204,000 ppbv at SV05D exceeded 50,000 ppbv during the January 2014 monitoring event—the first monitoring event following detection of the Tank 5 release. In contrast, a PID reading above 280,000 ppbv was not recorded at Tank 5 until 4 months after the Tank 5 release (i.e., 450,000 ppbv in April 2014 at SV05M). Thus, the 50,000 ppbv criterion would significantly improve response time without increasing the rate of false-positive results, which are important considerations in release detection. The proposed concentration criterion of 50,000 ppbv for tanks with Jet Fuel is an 82% reduction from the current criterion of 280,000 ppbv.

For the tanks containing Marine Diesel (Tanks 15 and 16), PID readings never exceeded 8,000 ppbv during any of the 168 monitoring events between March 2008 and December 2020 (RFI 9 Figure 4). Thus, a reading above 8,000 ppbv would represent an exceedance of the established baseline levels. The proposed concentration criterion of 8,000 ppbv for tanks with Marine Diesel is a 42% reduction from the current criterion of 14,000 ppbv.

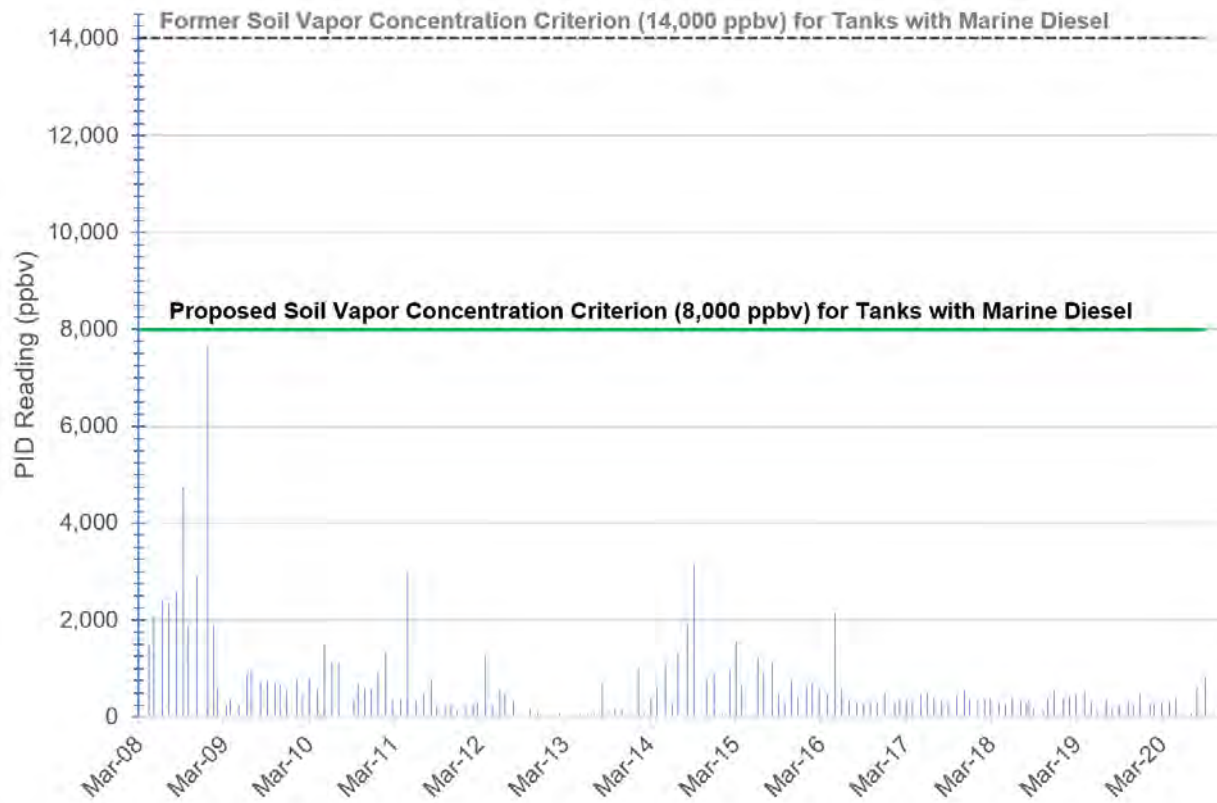

**RFI 9 Figure 4: Maximum PID Reading (Tanks 15 and 16) for Each Monitoring Event, March 2008 – December 2020**

The Navy proposes evaluation of the monthly soil vapor concentrations using reduced concentration criteria of 50,000 ppbv for jet fuel and 8,000 ppbv for Marine Diesel. The Navy would respond to any exceedance of the new proposed concentration criteria by: (a) sampling the SVMP for offsite laboratory analysis of the vapor sample for a wide range of hydrocarbons via EPA Method TO15 to help determine if the vapors are indicative of weathered fuel or a fresh fuel release; and (b) conducting causative research.

### **Concentration Trend Analysis**

Although the direct comparison of soil vapor concentration data to the concentration criteria is a robust, effective, and reliable release detection method, the current estimated concentration trend analysis is less effective. The estimated trend often results in identification of a “strongly increasing” concentration trend at a fuel tank SVMP, initiating notification of Fleet Logistics Center and a “causative research” response. For example, notification of Fleet Logistics Center and a “causative research” response was required for 8 of 12 monthly monitoring events in 2020. These concentration-trend-estimation-based causative research responses have never identified evidence of a release from a fuel tank (except for the Tank 5 release, which was much more effectively and quickly identified based on comparison of the actual data to the concentration criteria). In all these cases, the estimated increasing concentration trend did not persist beyond a

few months, and the PID readings remained within the historical baseline range (i.e., the actual data did not exceed the concentration criteria), indicating that the estimated trend was not indicative of a fuel release. Although the current trend analysis procedure has not proven useful for leak detection, the available monitoring record demonstrates that the revised concentration criteria discussed above are effective for leak detection. In addition, as part of the continuous monitoring pilot test, the Navy will evaluate whether trend analysis may be useful based upon the detailed, near real-time monitoring data generated by the continuous monitoring system.

Despite short-term variations in PID readings from individual SVMPs, the arithmetic average of PID readings across all SVMPs has exhibited a generally decreasing trend over time, with the exception of a large increase following the 2014 Tank 5 release, which suggests that the false-positive results of the current trend analyses are not indicative of releases. As shown on RFI 9 Figure 5, average PID readings in 2020 were similar to those in 2012–2013, prior to the Tank 5 release. This long-term trend in average PID readings is additional evidence of an absence of ongoing undetected fuel releases.

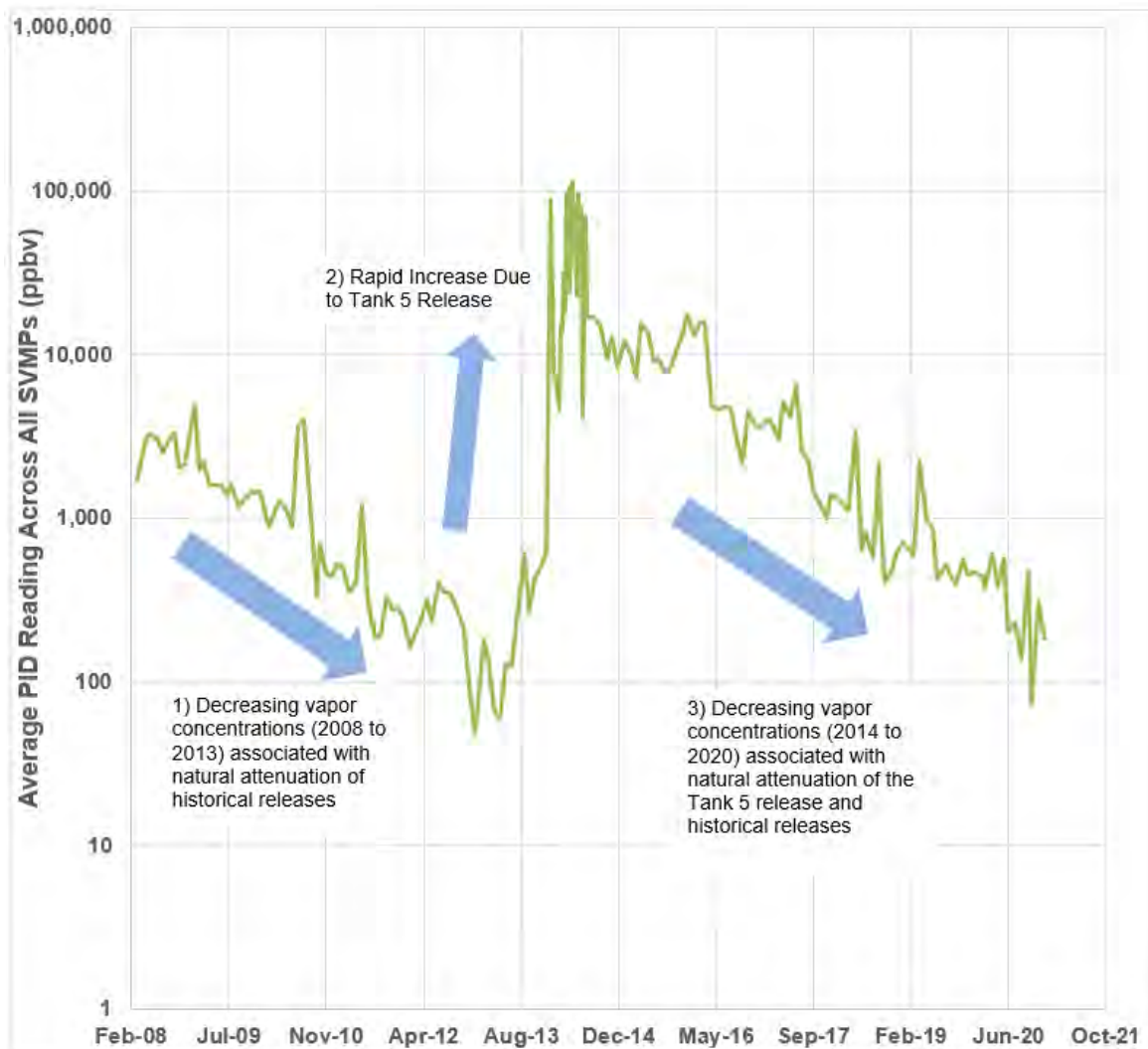

RFI 9 Figure 5: Average PID Readings Over Time, 2008–2020

## **Soil Vapor Monitoring as Complementary Release Detection Method**

Of the seven existing and two planned release detection methods, the following four release detection systems provide the bulk of the primary release detection data: (1) AFHE/ATG, (2) semiannual tank tightness testing, (3) SVM, and (4) groundwater monitoring.

**AFHE/ATG**, as described in more detail in Responses to RFI 1 and RFI 6, relies on reconciling fuel levels, pressures, and fuel temperatures at various levels in a tank as part of the ATG system, and this is integrated with an analysis of fuel movements in and out of a tank as part of the AFHE system. The ATG system has a capability of detecting fuel levels of  $\pm 1/16$  in. The combined AFHE/ATG system provides a means of inventory reconciliation and release detection. In addition, manual gauging is also conducted, and those results are compared to the AFHE/ATG results so that potential discrepancies can be identified and investigated. This system has a series of alarms (based on whether or not fuel is moving in or out of a tank), ranging from an initial alarm that requires further evaluation to high-level alarms that require defueling of a tank. The system works 24/7/365 and is continuously monitored by operators in the control room. The AFHE/ATG system is discussed further in RFI 11. While it is possible that certain volumes of fuel may be released in an undetected manner with AFHE/ATG, semiannual tank tightness testing, SVM, and groundwater monitoring provide additional layers of protection for fuel release detection.

**Semiannual tank tightness testing** is carried out by a certified contractor to demonstrate that tanks meet the Hawaii UST requirements for tank tightness testing of 0.5 gallon per hour. This evaluation is conducted twice per year and exceeds the regulatory requirements of once per year. Results of this testing also help to verify the effectiveness of the AFHE/ATG program.

**SVM** is currently conducted on a monthly basis as described above. When SVM concentrations reach a specified level, sampling of the SVMP with offsite laboratory analysis and the causative research process identified above are conducted. This program provides another means of release detection to backup AFHE/ATG and tank tightness testing. A pilot program for CSVM is currently being developed (as described in RFI 10) that may result in a significant enhancement to the monthly monitoring approach. When implemented on a site-wide basis, this program will provide another real-time evaluation of release detection that will supplement both the AFHE/ATG and tank tightness testing programs. If the pilot program is successful, the ultimate goal for the CSVM program will be to establish various alarms that will be continuously monitored in the control room. These alarms will likely consist of both absolute concentration alarms as well as a data trend alarm. Absolute concentration criteria may consist of a lower concentration level that is above background noise that may be indicative of a release. At this level, it is anticipated that both causative research and soil gas sampling for offsite laboratory analysis to evaluate for indications of fresh or weathered fuel will be required. A higher-level alarm (likely consistent with vapor levels seen in the 2014 Tank 5 release) may also be established that requires tank defueling. Finally, actual measured vapor trends will also be evaluated and if exceeded will require causative research. Currently, there is no way to assign either absolute vapor concentration or trend targets since these will be evaluated as part of the pilot CSVM program. These targets may be assigned for individual probes, all probes beneath a tank, or all probes as a function of fuel type depending on the results of the CSVM pilot test. It has been demonstrated that SVM can

detect larger releases such as the 2014 Tank 5 release; improved continuous monitoring may provide additional valuable information that will further support and enhance the release detection capabilities of the AFHE/ATG system.

**Groundwater monitoring** also provides additional release detection methods. First, groundwater monitoring wells in the tunnel are evaluated for the presence of light nonaqueous-phase liquid (LNAPL) on a quarterly or monthly basis. Second, all groundwater monitoring wells in the network are sampled and analyzed on at least a quarterly basis for the presence of chemicals of potential concern (COPCs). If either LNAPL or if COPCs are detected at concentrations exceeding regulatory or other screening criteria, additional actions are taken, which may include a detailed evaluation of the laboratory data, additional sampling, and comparison to results of the other release detection methods and data to ensure that potential releases are identified and dealt with.

This page intentionally left blank

## Response to RFI 10: Update on the Continuous Soil Vapor Monitoring Pilot Test

### **Regulatory Agencies' Comment:**

#### **Greater Detail on The Real-Time Soil Vapor Continuous Monitoring Pilot Study is Needed**

Real-time soil vapor monitoring can be an important source of information for an overall leak detection system and the Navy proposed implementing a continuous soil vapor monitoring pilot test. The pilot will consist of a monitoring system for one to three tanks using an auto-sampler PID. Results would be documented over 6 months to 1 year. However, the goals and details of a pilot program are not provided with sufficient detail.

- The Navy should develop goals and procedures for this pilot study in consultation with the regulatory agencies and other critical stakeholders.
- The performance criteria and method of evaluating the success of the pilot program; and a plan for terminating the pilot program should be clearly defined.
- The pilot proposal should clearly define the details of causative research tests or actions. For example, what constitutes an “outlier” versus what is statistically significant? More frequent readings will certainly give more volatility than a monthly sampling, which may be addressed through statistical calculations. How will the pilot study handle inconsistencies with monthly monitoring? What would a causative decision tree look like with a continuous monitoring approach compared to the monthly monitoring?
- The Regulatory Agencies' comments on the current SVM program should be considered in developing the scope of the pilot project.
- A proposed implementation schedule should be provided.

### **Navy Summary Response:**

The Navy monitors soil vapor underneath the Facility's 18 active fuel storage tanks on a monthly basis as one means of detecting a possible fuel release. The monitoring requires a field crew to collect and measure sample concentrations. The results are then evaluated and reported to the Hawaii State Department of Health (DOH) monthly. To improve its fuel release detection capability (and as a consequence, also improve groundwater protection), the Navy is actively exploring an automated system that would continuously measure the soil vapor with sensors that can immediately alert Facility operators if an immediate response action may be warranted. To determine if such a system can be installed Facility-wide, the Navy will first test the system at three fuel storage tanks to evaluate its feasibility, effectiveness, and reliability. The pilot test is being developed in coordination with the AOC Regulatory Agencies and is anticipated to be completed in approximately 6–12 months. An outline of the Navy's plan is currently being reviewed by the Regulatory Agencies.

## **Navy Detailed Response:**

The Navy is actively planning to implement continuous soil vapor monitoring (CSVM) at Red Hill to improve the Facility's release detection capabilities. The Navy proposes to first implement a CSVM pilot test to determine the feasibility, effectiveness, and reliability of such a system. Collaborative discussions with the Regulatory Agencies to solicit their input have provided helpful comments and suggestions. The Navy's plans for a CSVM pilot test will incorporate the Regulatory Agencies' feedback, and further continued coordination moving forward is anticipated.

Provided below is a general overview of the proposed CSVM pilot test.

### **Goals for a Full-Scale Continuous Monitoring System**

A full-scale continuous monitoring system would reduce the time scale for soil-vapor-monitoring-based release detection from months to days or hours. In addition, a continuous monitoring system would more accurately characterize baseline vapor concentrations at the various soil vapor monitoring probes (SVMPs), enabling more accurate release detection based on an improved ability to detect departures from these baseline conditions.

### **Objectives for the CSVM Pilot Test**

The overall objective of the CSVM pilot test is to determine the feasibility of installing and operating a full-scale CSVM system. Specifically, the pilot test will determine whether the equipment used is sufficiently reliable, robust, and effective. In addition, the pilot test will evaluate whether the data acquired from the continuous monitoring results are of sufficient quality (i.e., does the instrument have sufficient sensitivity, precision, and accuracy) to reliably identify a new fuel release while minimizing false-positive results.

### **Monitoring Equipment**

The pilot system will install a photoionization detector (PID) at a central monitoring station located in the Facility's lower access tunnel. The PID will be connected by polytetrafluoroethylene (PTFE; i.e., Teflon) tubing to three individual SVMPs (for a total of nine SVMPs) in Tanks 2, 5, and 7. This central monitoring station will include a 20-port stream sampler that allows the PID instrument to cycle through each of the connected SVMPs, producing a reading from each SVMP every one to two hours. Each sampling cycle will also include a sample of tunnel air to evaluate tunnel background air. The system equipment will also include a coalescing filter and a gas dryer to control sample moisture. For the pilot test, the monitoring results will be stored locally and retrieved periodically for evaluation. A full-scale system would include real-time data access and automated notification/alarm functionality.

### **Pilot Test**

System startup will include a number of quality assurance evaluations, such as the shut-in vacuum. This system tests the sample lines for leakage, and evaluates instrument accuracy, instrument precision, and tubing effects (adsorption/desorption) using standard gases introduced



at the monitoring station and at a tank's SVMP access port. After startup, the system will be operated for at least 6 months to evaluate equipment performance, and to document baseline soil vapor conditions at each of the nine monitored SVMPs.

During the operation of the pilot system, the Navy will continue to conduct existing monthly soil vapor data collection using current procedures. The Navy does not intend to use the pilot test data for release detection until appropriate baseline trends can be established. Quality assurance evaluations will be conducted during the pilot test to ensure that the continuous monitoring data meet accuracy, precision, and sensitivity objectives.

### **Offsite Laboratory Analysis**

To further understand variations in SVMP PID readings, the pilot test will include collection and offsite analysis of tank headspace or tank ventilation system samples (i.e., fresh fuel vapors) and baseline SVMP samples. These samples will be analyzed for individual petroleum-based volatile organic compounds by EPA Method TO-15, and the reporting will include a flame-ionization detector chromatogram for visual evaluation of vapor weathering. These initial samples will serve to document the "fingerprints" of fresh fuel vapors and the baseline vapors from the SVMPs. If feasible, additional "opportunistic" samples may be collected during the latter part of the pilot test to evaluate whether changes in observed PID readings correspond to changes in vapor composition.

### **Proposed Implementation Schedule for the CSVM Pilot Test**

The Navy is currently working with the Agencies and has developed a work plan for progressing this project forward. Once the pilot program is initiated, it is anticipated that the CSVM pilot test will last approximately 6–12 months. Part of that time may be used to perform additional sampling and acquire a better understanding of the observed variations in PID readings. The Navy anticipates starting the pilot test by August 2021.

### **Pilot Test Report**

After the pilot test is completed in the field, a final report will be provided to the Regulatory Agencies documenting equipment performance and monitoring results including the data quality evaluations. The equipment performance will be evaluated based on the accuracy, precision, and sensitivity of the monitoring data and the reliability of the equipment. The pilot test monitoring data set will be evaluated to characterize the baseline range of PID readings observed for each SVMP. In addition, observed variations within the baseline range will be evaluated to identify correlations with site operations (e.g., fuel transfers) and other factors (e.g., wind, precipitation). The report will provide the basis for a collective decision by the AOC Parties on whether to implement a full-scale CSVM system. If a full-scale CSVM system is implemented, the pilot system monitoring data set will be used to develop preliminary causative decision points. The CSVM causative decision points will be used to identify concentration criteria and methods for characterizing trends that may suggest deviations from baseline monitoring results and may potentially indicate a fuel release. The CSVM causative decision points may include multiple response tiers; for example,

a “further investigation” tier based on a modest deviation from baseline that is possibly indicative of a (likely smaller) fuel release, and an “emergency response” tier based on a stronger deviation from baseline that is likely indicative of a (possibly larger) fuel release.

## Response to RFI 11: Red Hill Response Action Plans

### Regulatory Agencies' Comment:

#### **A Detailed Release Response Action Plan Needs Be Included in the Decision Document**

Ability to identify and respond rapidly to indications of a release is critical to effective risk mitigation. In the event of a confirmed release, the Navy will need available ullage to quickly drain the tanks and prevent more fuel to release into the environment. The Decision Document mentions having available ullage, but is silent on how this response process will be implemented.

The Decision Document should describe in quantitative terms the response procedures and timelines, and how these procedures are optimized in order to achieve effective risk mitigation. For example, this description should include:

- When a drain down is warranted or when a tank tightness test should be initiated. This should include how the multiple lines of evidence related to release detection will be utilized in an objective manner to trigger an immediate response action such as drain down, or how the integrated release detection system consisting of vapor monitoring, inventory monitoring, visual inspections, manual gauging, will trigger one another or the initiation of a tank tightness testing.
- New procedures that allow operators to transfer fuel out of a tank within 36 hours. Although mentioned on page 11 of the Decision Document, there is no information to substantiate this duration. Contradictory to this claim, on page 183 of the Navy's New Release Detection Alternatives Report, dated July 25, 2018, two hypothetical release response scenarios referenced longer time frames for emptying a tank (96.3 hours and 118.6 hours). A clear description of the improvements made/proposed that allow for this significant improvement should be provided. After the 2014 release from Tank 5, the draining process took approximately 5 days, January 13- 17, 2014. If spare ullage is not available, draining could take longer.
- Bounding estimates of possible release volumes based on the release response plan for various release scenarios (minor, significant, and catastrophic).
- A detailed description of training and drills to be implemented to assure that the release detection and response procedures are effective and will perform as planned.

## **Navy Summary Response:**

The Navy's release response plans and procedures for the Red Hill Facility follow the requirements listed in Hawaii Administrative Rule (HAR) 11, Subchapter 6 of Hawaii's Underground Storage Tank (UST) rules, "*Release Response Action*,"<sup>9</sup> as well as the detailed procedures described in the Facility's recently updated *Red Hill Fuel Storage Facility (RHFSF) Response Plan* (the "Response Plan") (CNRH 2020). The Response Plan, which is included as Appendix B, is the Navy's official plan for responding to potential releases and answers many of the Regulators' questions as they relate to hypothetical release scenarios.

As described in the Responses to RFIs 6, 7, and 8, release response would begin immediately if one of the many release detection systems were to indicate any suggestion of a potential release. Red Hill control room watch-standers then instantly trigger a causative analysis. Causative analysis is the evaluation of all available information, including checking other applicable release detection systems, depending on the nature, location, and type of event, to confirm whether a potential release has occurred. As described in other Responses to RFIs, the Navy proposes installing and investigating additional on-demand and continuous real-time release detection methods as part of the Best Available Practicable Technology (BAPT). This will greatly aid in faster release detection and response, accelerating response and mitigation. Should a suspected release be confirmed, available ullage and other storage options are immediately evaluated and corresponding tank drain-down procedures initiated, as described below.

The Regulators asked the Navy to investigate several theoretical release scenarios. Through collaborative efforts with Regulators in determining the hypothetical scenario parameters, the Detailed Response below provides estimates of hypothetical release volumes and drain down durations based on several notional scenarios that bound hypothetical release conditions and outlines the Navy's training program.

## **Navy Detailed Response:**

The Red Hill Facility's overall release response action plans include: effective release detection, evaluation, and drain-down procedures; response strategies; and continuous training. These elements of release response are summarized in the following sections. More details are provided in the *Red Hill Response Plan* (Appendix B), which is incorporated as part of this response.

To be clear, much of the information contained in this RFI response is based on theoretical situations that are designed to assist the Regulators in understanding potential responses to a wide range of hypothetical releases.

<sup>9</sup> <https://health.hawaii.gov/shwb/files/2020/01/11-280.1-Jauary-17-2020-Standard-format-with-summary-and-signature-pages.pdf>

## **1 Release Detection and Tank Drain Down**

As described in previous Response to RFIs, the Navy currently uses seven (7) independent methods for release detection at the Red Hill Facility, plus two (2) additional methods recommended for implementation or further evaluation that could provide additional real-time release detection data. The primary method currently in use at all times is the Automated Fuel Handling Equipment (AFHE)/Automatic Tank Gauge (ATG) system. This system also verifies a potential release during tank tightness testing, which the Navy currently conducts on a semiannual basis—twice as often as required by the State of Hawaii—with no tank having ever failed a test.

Along with the new Red Hill Tank Inspection, Repair, and Maintenance (TIRM) process, which was approved by the Regulators in September 2017 (NAVFAC EXWC 2017), analysts track daily inventory levels and quantities of fuel, both in feet and gallons, for each fuel tank. Fuel operators are constantly tracking the fuel inventories and level of the tanks to ensure that the fuel is staying put or moved and tracked with purpose. This is done by using the ATG system, which collects fuel level measurements with a high degree of accuracy (within 1/16 inch in a 250-foot-tall fuel tank). The Responsible Officer signs physical inventories daily that reflect total on-hand quantity of each Defense Working Capital Fund petroleum grade stored at the fuel terminal. Operators at the Red Hill Facility routinely manually gauge each tank to verify the integrity and preciseness of the ATG system.

The AFHE system continuously manages the fuel inventory data in every fuel tank and pipeline, alarm conditions (to include low and high-level alarms in the fuel tanks), fuel metering, as well as low and high-pressure conditions. The operators also have the ability to view system statuses and control valve positions and pumps, used to move fuel from one storage vessel to another. The AFHE system is essentially a distributed control system that provides remote, real-time monitoring of the fuel distribution system and is integrated into the fuel handling and storage system installed at the Red Hill Facility. The system improves the efficiency and safety of fuel operations by providing the remote monitoring and control of fuel storage and transfer operations, thus improving data management in real time. The Response to RFI 7 further describes the capabilities of the AFHE/ATG system as well as tank drain-down procedures resulting from a hypothetically indicated release condition.

As further described in the Responses to RFIs 6, 7, and 8, all the other existing and proposed release detection methods have their own triggering events or levels that can be used to either trigger a response or confirm the results of any other release detection method, including AFHE/ATG. The Response to RFI 9 describes how the release detection systems are integrated together.

The following subsections describe the primary factors related to the tank draw-down process.

### **1.1 Tank Alarms and Unscheduled Fuel Movement Thresholds**

The fuel tanks' high-high and overfill levels are displayed on RFI 11 Figures 1 and 2, along with tank capacities, and maximum flow rates. These diagrams give a basic overview of the tank alarm set points, which define the tanks' operating limits. Unscheduled Fuel Movement (UFM)

thresholds are set in the AFHE system to trigger at a set point, noted in the diagrams below, to generate a UFM warning alarm to the operator. RFI 11 Figure 1 shows the Red Hill Tank 15 alarm set points, which are representative of previous tank operating limits and alarm thresholds. RFI 11 Figure 2 shows the Red Hill Tank 5 alarm set points, which have been modified in the new TIRM process to lower the operating levels and alarm set points to provide extra protection against overfill and reduce potential release quantities, as well as to provide additional ullage beyond what was available under the previous operating levels. Using these two tanks as an example, the normal high operating limit of a Red Hill tank was lowered by more than 30 feet. This new operating limit height (190 feet 9.0 inches in Tank 5) is approximately 23 feet below the upper dome. The expansion joint of a typical Red Hill tank starts at 200 feet and extends upwards 12 feet, such that curvature of the upper dome begins at approximately 213 feet. These new lowered operating levels and alarm set points will be applied to the remaining tanks as they undergo the new TIRM process.

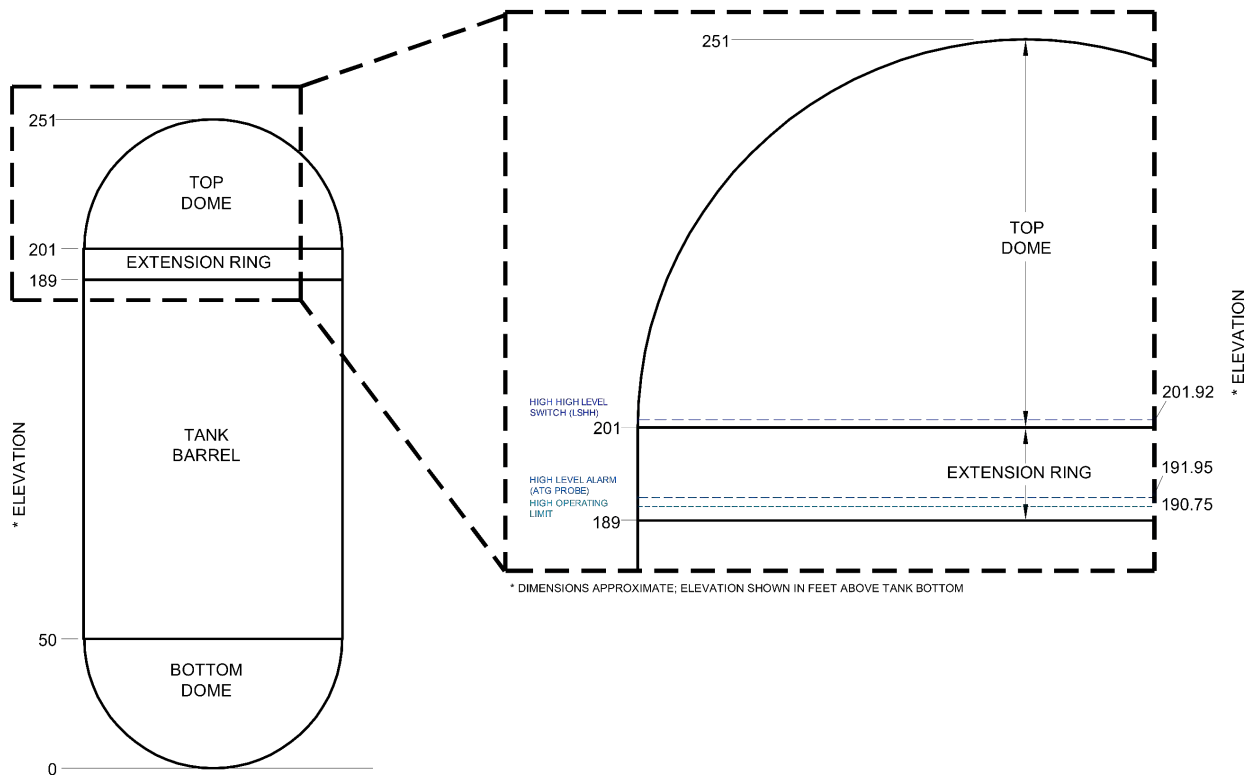

**RFI 11 Figure 1: Tank 5 AHFE Alarm Set Points**

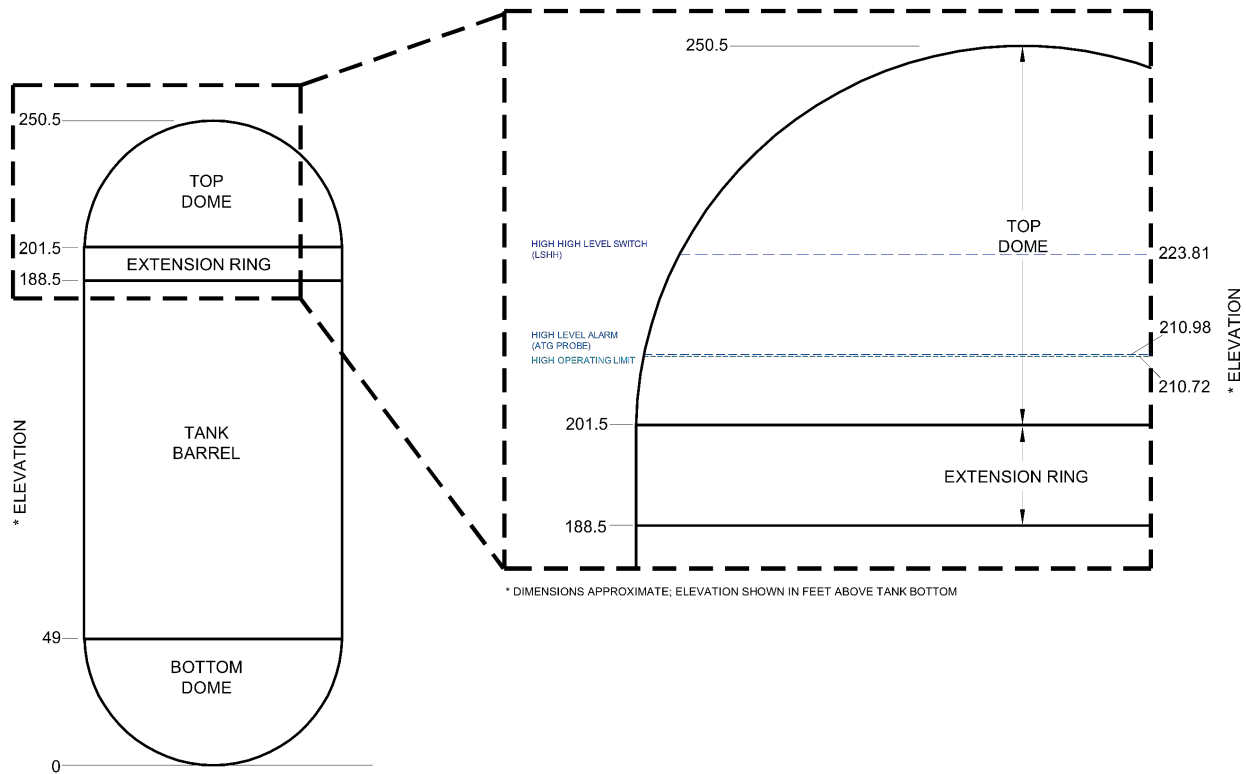

**RFI 11 Figure 2: Tank 15 AHFE Alarm Set Points**

## 1.2 Release Response Event Sequence Diagram for General Tank Releases

As described in the *Red Hill Response Plan* (Appendix B):

*“ATGs on each of the Red Hill Facility tanks are calibrated at least once per year to an accuracy of 3/16 of an inch. The Navy also verifies ATG measurements after each fuel movement by manually gauging the tanks with a tape measure calibrated annually by the National Institute of Standards and Technology. Any discrepancies between the ATG measurements and manual gauging greater than 3/16 of an inch are investigated to identify potential releases. In addition, the Navy attempts to detect any UFM’s, including releases, from their UST system by collecting and processing ATG data using the AFHE System. Space and Naval Warfare Systems Command (SPAWAR) administers the AFHE system, and control room operators receive alerts of any potential UFM’s. AFHE accounts for volumes that move through the UST system using flow meters, and ATG data combined with strapping charts. Under static conditions (no fuel transfers), AFHE generates a warning alarm any time there is an apparent net loss or gain of more than 1/2 of an inch of fuel in one of the tanks, and a critical alarm for more than 3/4 of an inch. During scheduled fuel transfers, AFHE generates a warning alarm for more than 1 inch, and a critical alarm for more than 1 and 1/2 inches.”*

RFI 11 Figure 3 shows the Event Sequence Diagram (ESD) for a hypothetical release situation detected by the AFHE/ATG system. Event sequences initially diverge based upon whether the tank is idle or aligned for a fuel evolution (i.e., issue, receipt, or inter-tank transfer) when the

release is detected. During return to service, the tank filling process includes up to ten pauses. Each pause lasts for 48 hours as the fuel level incrementally increases, allowing for checks on the integrity of the tank at each incremental fill level, as opposed to filling the tank all the way from empty to full in one or two receipts. It is therefore possible to detect any problem in the tank during each of these ten pauses, prior to filling the tank to the maximum operating level. This eliminates the practice of halting drain-downs to find the location of any theoretical future releases, limiting the quantity of such a release. Manual top gauge readings can also be taken and trended by operators. Given an AFHE low-level or warning or critical alarm, the operators are tasked by procedures to confirm the readings of the AFHE by performing one or more top gauges manually. The operators are also tasked to perform a manual top gauge within 2 hours each time a fuel movement ends. The AFHE and the top gauger would identify and confirm any decreasing fuel levels in the tank before further action would be taken. The Responsible Officer also verifies all fuel inventories in gallon quantities and levels on a daily, weekly, and monthly basis, which offers a secondary check to what the Control Room Operators are visually seeing in the AFHE system.

If an actual release is confirmed, management and the Red Hill supervisor are notified of the situation. Typically, and for the ESD on RFI 11 Figure 3, the response involves a strategy for moving fuel from the tank in question. This mostly involves opening the skin and ball valves of the then-idle tank and directing the fuel to other tanks (either at Red Hill or elsewhere in the overall system) that have ullage. The Red Hill staff would then operate valves and possibly cargo pumps to implement the plan to drain down the tank as quickly as possible to minimize any potential release. The quantity of any hypothetical release would be a function of many variables, including the release rate, the initial fuel level, the release location in the tank, the time to detect the release, and the duration of tank-drain down.

The last stochastic event in the ESD includes a variety of actions and fuel movements that may be chosen or are necessary to affect the tank being emptied. The bottom of the ESD begins where the Red Hill staff is tasked to implement the plan to empty the tank. Although the tank in question, depending on the level of the hole, may not have to be fully emptied to uncover the hole, the policy is to empty the tank in its entirety.

As presented in the ESD, five (5) approaches may be involved in the plan to transfer (“XFR”) fuel out of a tank:

- XFR1 – Inter-Tank Transfer by Gravity
- XFR2 – Move Fuel to Upper Tank Farm by Gravity
- XFR3 – Cyclically Move Fuel to Another Tank Using the Cargo Pumps and Surge Tanks or via the Upper Tank Farm
- XFR4 – Move Fuel by Gravity to Alternate Tanks or Ships at Pearl Harbor
- XFR5 – Drain the Last 7.5’ of Fuel from the Lower Dome Using the Fuel Lines to the Underground Pump House



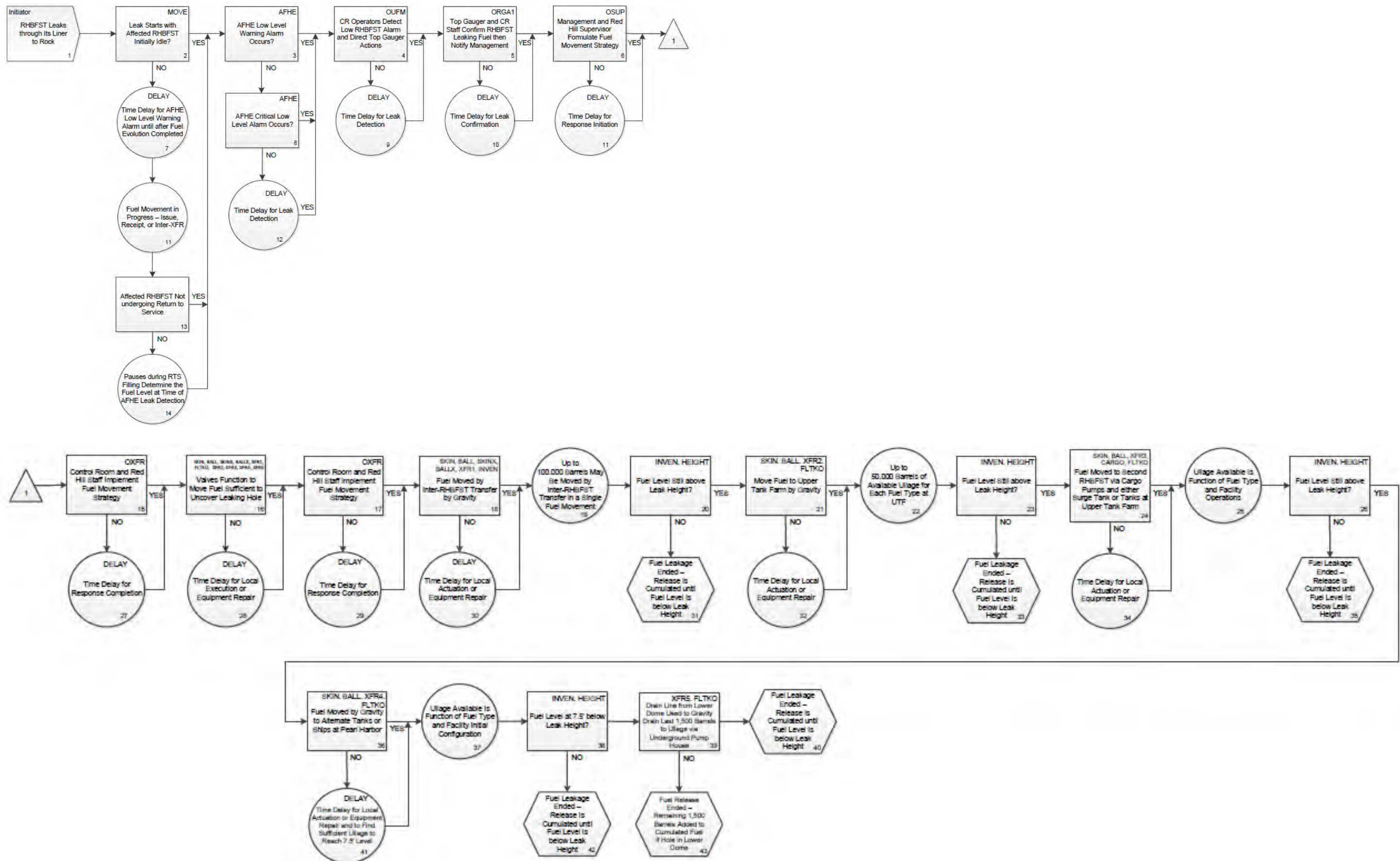

RFI 11 Figure 3: Event Sequence Diagram for Tank Release Directly to Rock

This page intentionally left blank

Not all these approaches may be necessary to completely empty a tank, depending on the initial height of fuel. In the 2014 Tank 5 release incident, XFR methods 1, 2, 3 and 5 were used; XFR method 4 was not. There are no procedural requirements of what order to implement these alternate approaches. It is likely, however, that XFR methods 1 and 2 would be given priority. Inter-tank transfers by gravity or to ullage in the Upper Tank Farm at Pearl Harbor not only are a rapid way to move fuel but would also be most effective if a hypothetical release is initially at its highest fuel level. Using the cargo pumps to move fuel to other tanks of the same fuel type allows one to take advantage of the ullage in those tanks.

The XFR 5 involves draining the final 7.5 feet of fuel. The connecting pipe to the Facility's lower access tunnel, which penetrates the lower dome, also sticks approximately 7.5 feet into a tank. Therefore, this pipe cannot be used to empty the bottom 7.5 feet of fuel. Instead, a gravity drain is connected to the main fuel line to remove the last approximately 1,500 barrels or 61,500 gallons of fuel.

### **1.3 Release Response Event Sequence Diagram for Overfilling**

The ESD for tank release resulting from overfilling a tank is presented on RFI 11 Figure 4. This ESD was developed based on the facilities operational guidance provided by Red Hill standard operating procedures and based on responses to questions posed to Red Hill operations staff. The top of the event sequence shown on RFI 11 Figure 4 assumes that a tank was being raised to its maximum operating level, and is triggered by a hypothetical error that fails to stop the fuel from being added at the applicable operating level. This event is highly unlikely because (1) the source tank operator will also be monitoring the level draw down in that tank and will alert the fuels department that too much fuel is being transferred, and (2) the high-high-level alarm automatically stops the tank from overfilling, irrespective of any operator error. In the event that the automatic shutoff valve does not actuate and the tank fill continues, the following response actions will occur.

If filling were to continue above the maximum operating level, the ESD assumes that there could be a hypothetical hole through the tank liner above the maximum operating level. If not, the sequence would end with no release of fuel. There is also a large ventilation hole at the top of the upper dome in each tank. However, overfilling by the amount of fuel needed to reach this level at the peak of the upper dome is judged not credible, because it would require an extra 6,500 barrels or 266,500 gallons to reach the upper dome opening, above the inventory needed to raise the level to 212 feet where the hole is postulated to be located. At roughly 2,500 barrels per hour, this would mean the overfilling above the planned stopping level would have to last for more than two (2) hours.

Although this release is highly unlikely, at a fuel level of 221.9 feet, more than 10 feet above the planned fuel level to stop at, a high-high-level alarm probe would be sounded in the Control Room. If the automated high-high alarm were triggered, the alarms would trip the cargo pumps and close off the tank from being overfilled immediately. If the overfilling continued, a high-high-level alarm mechanical switch located inside the tank would be actuated. This switch would signal the tank's skin valve to close and the cargo pumps to be tripped, either of which terminates the receipt

before the fuel level reaches 224.6 feet; i.e., at a fuel level still more than 15 feet below the top of the upper dome. This branch of the ESD would occur if all automated functions fail and the operator had to intervene to stop the overfilling of the tank and then commence tank drain-down procedures. The ESD actions deviates based upon whether the skin or ball valves close to terminate the overfilling. Tripping of the Red Hill cargo pumps is not normally seen as another layer of protection, but it is an important safeguard which prevents overfilling of a tank. The skin and ball valves are redundant and highly reliable pieces of equipment.

After overfilling ceases, the ESD on RFI 11 Figure 4 proceeds to the lower panel. The model postulates that the hole above the maximum operating level is just barely above it, at 212 feet. Therefore, the fuel above 212 feet starts releasing while the overfilling continues during the time it takes to detect the later drop in fuel level after the overfilling ends, and then also during the time it takes to empty the tank to a level below the postulated hole location. The ESD considers the response of the AFHE low-level warning alarm after tank settling and a decrease in level of 0.5 inch. This would be the first automatic cue to the Control Room Operators that there not only was an overfilling but that, as a result, a release from the tank was occurring. As with any fuel movement, after a two (2) hour period of tank settling, the top gauger would be tasked to top gauge the affected tank even before the low-level warning alarm.

If a suspected release is confirmed, management and the Red Hill Supervisor are notified of the situation. The Red Hill Supervisor is then tasked with executing the plan for a response and notifying the Red Hill staff. Typically, and for this ESD, the response involves the plan for moving fuel from the tank. This mostly involves opening the skin and ball valves of the then-idle tank and directing the fuel to other tanks (either at Red Hill or elsewhere in the overall system) that have ullage. The Red Hill staff would then operate valves and possibly cargo pumps to implement the strategy to drain down the tank as quickly as possible to minimize the release. The release quantity is a function of many variables, including the release rate, the initial fuel level, the release location in the tank, the time to detect the release, and the duration of tank-drain down.

One difference in the tank overfilling scenario is that it is very likely that there is sufficient ullage for moving fuel since a different source tank would have been used to fill the overfilled tank. Thus, ullage is immediately available for drain down. In addition, to stop the release only a small portion of the total tank capacity (i.e., above the normal operating levels) would have to be offloaded.

The release quantity is a function of many variables, including: the release rate; the initial fuel level; the release location in the tank; the time to detect the release; and the duration of tank drain down. The last stochastic event of the ESD includes a variety of actions and fuel movements that may be chosen or are necessary to affect the tank being emptied.

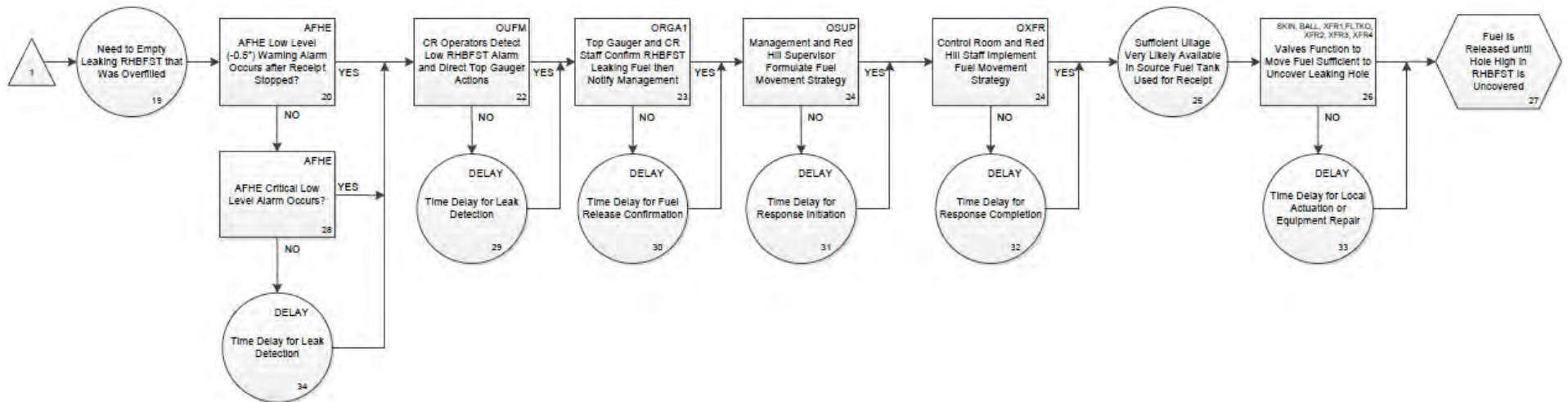
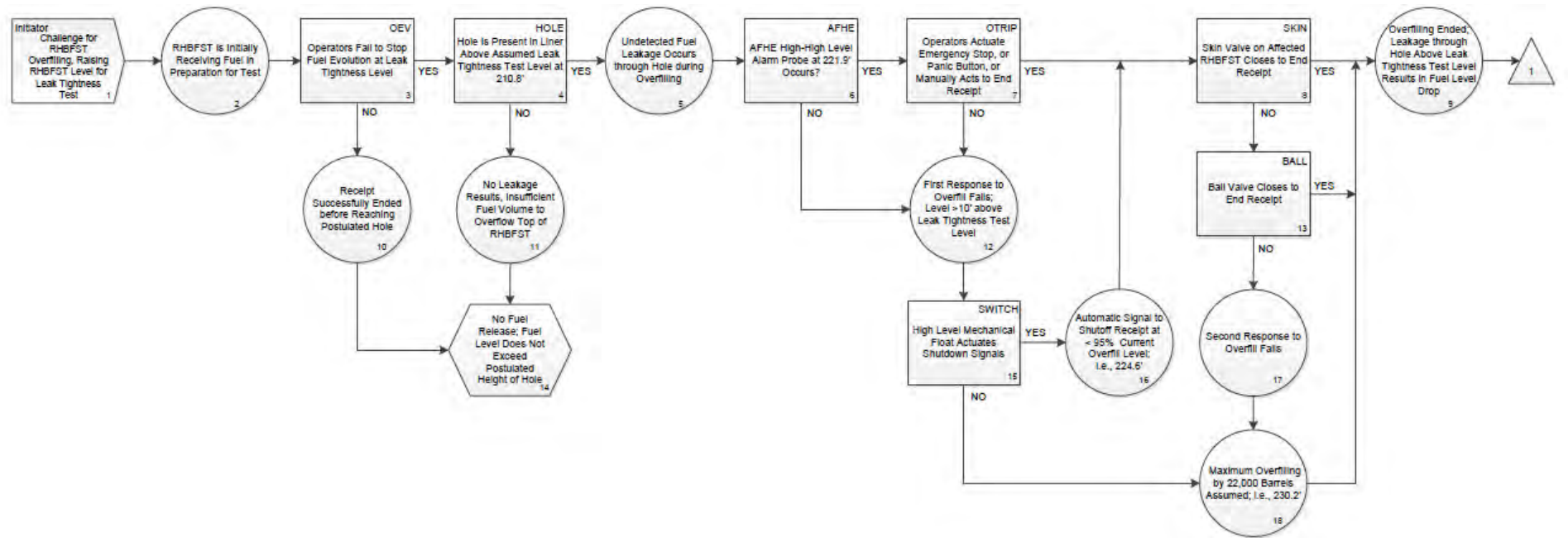

RFI 11 Figure 4: Event Sequence Diagram for Release Resulting from Overfilling a Tank

## 1.4 Time Needed to Drain a Tank

The 36-hour estimate for tank drawdown mentioned in the Tank Upgrade Alternatives and Release Detection Decision Document (DON 2019c) is one of several possibilities. Therefore, Appendix C provides detailed analyses of the time that may be required to drain a tank under various hypothetical scenarios, which is highly variable depending on a wide variety of factors.

## 1.5 Bounding Estimates for Four Release Scenarios

Appendix D provides bounding estimates of release quantities corresponding to various hypothetical release scenarios. Specifically, four hypothetical release scenarios were developed based on a request and discussions with the AOC Regulatory Agencies to help describe the operator responses and strategies to combat a fuel release from the Red Hill Facility over a wide range of conditions:

- Scenario #1: Minor Release (0.04 gallons per hour [gph] flow rate)
- Scenario #2: Small Fuel Release (0.08-inch hole or 1.5 gallons per minute [gpm])
- Scenario #3: Medium Fuel Release (0.5-inch hole or 72 gpm)
- Scenario #4: Large Release (e.g., due to nozzle failure)

RFI 11 Table 1 summarizes the bounding estimates of hypothetical release volumes under these four scenarios, which are presented in detail in Appendix D.

**RFI 11 Table 1: Summary of Four Release Scenarios Developed for Bounding Estimates**

Scenario	Release Rate	Time to Empty Tank (hours)	Estimated Quantity of Fuel Released (gallons)
1 Minor Fuel Release	0.04 gph	96	310
2 Small Fuel Release	1.5 gpm	96	10,370
3 Medium Fuel Release	72 gpm	Not applicable; terminating the tank overfill stops release	Dependent on operator response time to overfilling; maximum possible: 922,500
4 Large Fuel Release	Not specified	Not specified	12.7M

## 2 Response Strategies

The *Red Hill Response Plan* (Appendix B) details critical actions for a hypothetical fuel release emergency, as the Navy continues to be prepared to protect the water and the environment during Red Hill operations. These actions include notifying the Chain of Command and federal and state regulatory agencies as well as activating a spill response contractor to assist with oil spill response and clean-up. Fuel spill response strategies vary for small, medium, or large hypothetical releases. While the fuel terminal managers coordinate the overall efforts of the fuel spill response, the operators and watch-standers have an active role in identifying an active fuel release and notifying management. The Control Room Operators actively identify the steps to take to confirm, mitigate, and stop the release. This includes taking actions through the ESDs, executing a tank

drain-down plan, and initiating fuel spill response procedures for tank release and releases resulting from overfilling a tank.

## **2.1 Actions to Prevent a Large Fuel Discharge**

Actions to prevent or mitigate a large fuel discharge include:

- Close the oil pressure door located just down the lower access tunnel, past Tanks 1 and 2. The door can be closed by pushing the manual push button on the bulkhead to the side of the door. The door will also automatically close immediately when the high-level float in the oil pressure door lift sump indicates that the sump is full. Closure of the door triggers the fire alarm system.
- Close the three isolation doors located in the lower access tunnel: Doors A, C, and the entrance to the underground pump house. These doors are designed to stop a spill from migrating down the tunnel and will automatically close in the event of a fuel spill.
- Fleet Logistics Center Pearl Harbor Fuel Department maintains a heightened inspection and maintenance program for the Red Hill Facility. All tanks are currently undergoing, or will undergo, a modified American Petroleum Institute (API) 653 inspection process. Tanks are pressure tested semiannually; pipelines are regularly inspected and pressure-tested.
- Fleet Logistics Center Pearl Harbor Fuel Department conducts regular Oil Pollution Act spill training and exercises.

## **2.2 Fuel Escaping and Remaining in the Tunnel**

Under this supposed scenario, the harbor tunnel and Adit 2 spur tunnel could possibly be inundated with fuel that could reach Adit 2 in as little as 22–25 minutes after the release and potentially escape via Adit 2. Some of the response strategies and operations that could be employed are discussed in the following subsections (additional response strategies are described in the detailed *Red Hill Response Plan* [Appendix B]).

## **2.3 Containing Fuel Escaping Adit 2**

Adit 2 is located within a natural depression with steep embankments nearby. Directly in front of the adit are Buildings 352 and 400, surrounded by large parking areas. In the event of a release, storm drain blockers can be deployed in the parking areas to prevent fuel from reaching Halawa Stream. Fuel captured in the parking area could be pumped into tank trucks and transferred to empty storage tanks or a ship waste offload barge.

## **2.4 Pumping Fuel Out of Adits 1 and 2, and Harbor Tunnel**

Fuel remaining in the tunnels, approximately 1.9 million gallons, will be pumped out of the adits and tunnels. The harbor tunnel sump pumps can be configured to pump fuel through the isolation door that separates the harbor tunnel from the underground pump house. The sump pumps are designed to send oily water (or fuel in this case) to the Adit 1 sump which can then be sent to the swale or to Tanks B-1 and B-2 (378,000 gallons each) at the Fuel Oil Reclamation Facility. From these tanks, fuel can be moved to various locations such as the Upper Tank Farm or to a ship waste offload barge or a fuel oil barge (YON) at Hotel Pier (see the Fuel Department's *Operations*

and *Maintenance Manual* for details). Portable pumps could also be staged outside of Adit 1 to pump fuel out of the adits and tunnels.

## 2.5 Fuel That Could Impact Surface Water

Theoretically, if fuel were to impact Halawa Stream or Pearl Harbor, the plan would be to contain and recover as much fuel as possible near the source of its entry into Pearl Harbor. The overall strategy will be to prevent fuel from spreading further into East Loch or the Entrance Channel, and to protect the sensitive shoreline and historical resources in and around the immediate spill location.

With fuel impacting the water, the On Scene Incident Command will immediately call the Joint Base Pearl Harbor-Hickam Port Operations Control Tower. Port Operations will activate the Facility Response Team, who will respond with boom, boats, skimmers, and vacuum trucks. Port Operations will also order the evacuation and closure of the Arizona Memorial and clear the area of all vessel traffic. The Facility Response Team will attempt to contain and recover the fuel in Halawa Stream before it escapes into Pearl Harbor by booming the entrance to the stream and using skimmers and vacuum trucks to recover fuel.

## 2.6 Containment and Fuel Recovery Booming Strategy for Halawa Stream

**Note:** This booming strategy is for guidance only. All booming strategies may need to be adjusted depending on the tides, current, wind, availability of equipment, and movement of fuel.

### Booming Strategy:

Contain and recover fuel from Halawa Stream/Pearl Harbor and to protect environmentally sensitive areas.

### Site Conditions:

Near the mouth of Halawa Stream, the water is sufficiently deep for utility boats until approaching the shoreline.

Booming site is tidal and may be affected by the prevailing wind direction.

### Initial Response Equipment:

**Boom\*:** Approximately 800 feet of 24-inch harbor boom depending on water current and weather conditions. Mouth of stream will be double-boomed with two 400-foot lengths of boom.

**Vessels:** Two platform boats, four utility boats, and two skimmers



**Vacuum Tucks:** Seven vacuum tucks are available

- 2 @ Facility Response Team, 808-472-9942
- 3 @ Naval Supply Systems Command, Fleet Logistics Center Pearl Harbor, 808-473-7801
- 2 @ Naval Facilities Engineering Systems Command, Hawaii, 808-471-8481

**Personnel:** 2 to 3 crew per vessel; 1 to 2 personnel per vacuum truck

**Boom attachments:** Connect to fixed objects on both sides of the mouth of Halawa Stream

- Initial Response time: < 1 hour

#### Fuel Recovery:

- The mouth of the stream will be boomed with skimmers working within the boomed area recovering fuel. Vacuum trucks will be staged on the shoreline adjacent to the stream mouth (Navy side) to recover fuel using skimmers.

All release response actions will follow the regulations set forth by the *Red Hill Response Plan* (Appendix B) and the Hawaii State Department of Health, State Administrative Rules, Underground Storage Tank, Chapter 11-280.1, Subchapter 6, Release Response Action (effective January 17, 2020).<sup>10</sup>

More detailed response actions are described in Appendix E.

### **3 Training and Drills**

The *Red Hill Response Plan* (Appendix B) is a detailed oil spill response plan approved by Commander, Navy Region Hawaii (CNRH) and meets all regulatory requirements in the Oil Pollution Act of 1990. All operators and watch-standers at the Red Hill Facility are trained in spill response on an annual basis and require in classroom training and field training. The field training allows the operators to be well-versed in responding to a small, medium, and large fuel spill (all simulated in a training environment) in the event of an actual emergency.

The Red Hill Fuel Facility Class must be in compliance with the Federal Energy Policy Act of 2005, which requires each state receiving Resource Conservation and Recovery Act (RCRA) Subtitle I funding to develop state-specific operator training requirements. Class A, B, and C Operators complete initial training within 30 days of beginning work. Class A and B Operators are recertified every 5 years, and Class C Operators are retrained and recertified on an annual basis. All operators receive certificates upon validation of the required training. Class A Operators are persons with the primary responsibility for the operation, maintenance, and compliance of the

<sup>10</sup> <https://health.hawaii.gov/shwb/files/2020/01/11-280.1-Jauary-17-2020-Standard-format-with-summary-and-signature-pages.pdf>

UST system. Class B Operators are individuals that have the responsibility for day-to-day implementing of regulatory requirements. Class C Operators are the first line of defense in emergency response conditions of the UST system. The Oil Pollution Act of 1990 mandates Annual Oil Spill Response Training and all the operators at the Red Hill Fuel Facility attend the annual training and receive Oil Spill Response Training Certification. In addition, all Control Room Operators receive annual refresher training on the AFHE to ensure that operators are receiving sufficient training for proficiency to operate the Red Hill Facility for routine, non-routine, and emergency situations.

## Response to RFI 12: Minimal Contamination Would Result from a Hypothetical Minor Release

### **Regulatory Agencies' Comment:**

#### **Evidence is Needed to Support the Claim that Minimal Contamination will Result from a Minor Release**

The Navy claims that even in the unlikely event of a minor release, the multiple layers of release detection listed in the Decision Document will be able to detect releases and, because of their response action plans, there will be minimal contamination allowed into the environment. The Decision Document does not provide sufficient information to make this case and should be revised to provide quantitative analysis and evidence of this risk mitigation achieved through these improvements. Bounding estimates of possible release volumes based on the release response plan for various release scenarios, as mentioned in the previous comment, can help with this illustration. In addition, if damages occur, what plans are in place to address potential resource damages?

Minor releases are defined on page 97 of the Decision Document as releases occurring at rates less than 0.5 gph (or 4,380 gallons per year). Questions remain about how quickly the Navy would be able to respond to various types of releases and mitigate the release.

### **Navy Summary Response:**

The Response to RFI 11 provides bounding estimates of hypothetical release volumes, durations, and response times under a wide range of scenarios, including minor releases as requested by the regulators. The significant body of available data does not confirm that any such minor releases are occurring at present but does indicate that several natural processes operate to protect the environment from historical releases. Nevertheless, plans for engineered safeguards have been evaluated and are being developed, pending regulatory concurrence. It is important to reiterate that these calculations are necessary to understand the level of risk but should in no way be inferred to mean that the Navy considers any release acceptable. In addition, the regulatory agencies established the release detection rate (0.5 gph), recognizing any release below that detection threshold would not likely have any adverse impacts on the environment.

### **Navy Detailed Response:**

The Response to RFI 11 provides quantitative estimates of a broad range of hypothetical release scenarios, including calculation of associated estimated response times and release volumes:

- Scenario 1 – Minor Release (0.04 gallons per hour [gph])
- Scenario 2 – Small Fuel Release (0.08-inch hole with a release rate of 1.5 gallons per minute [gpm])
- Scenario 3 – Medium Fuel Release (0.5-inch hole with a release rate of 72 gpm)
- Scenario 4 – Large Fuel Release Hypothetical Nozzle Failure

As described in various other Responses to RFIs in this document, the Navy uses seven separate forms of release detection that support and overlap each other with the ability to identify a range of potential release scenarios. The four primary methods are: Automated Fuel Handling Equipment [AFHE]/Automatic Tank Gauge [ATG], semiannual tank tightness testing, soil vapor monitoring [SVM], and groundwater monitoring. Each of these methodologies has associated action levels designed to minimize environmental impacts should a release occur.

Tank tightness testing at the Red Hill Facility exceeds Hawaii regulatory requirements by performing 0.5 gph (12 gallons per day) tank tightness testing on a semiannual basis (rather than once per year as required by the State's Underground Storage Tank [UST] regulations). The Navy also uses several additional release detection methods not required by the regulations. As with any UST system, it is conceivable that small releases too low to detect might occur. Even if a small release below 0.5 gph were to occur, it is likely that the combination of AFHE/ATG trend analyses, manual trend analysis, tank tightness testing, and SVM would detect such a release. If an undetected minor release of this magnitude were to continue over a period of time, it might exceed the natural source-zone depletion (NSZD) rates that have been documented and would likely be evidenced by SVM, even if the AFHE/ATG and tank tightness testing systems were not able to detect this small of a release. With the exception of the 2014 Tank 5 release, soil vapor trends are generally decreasing and concentrations in groundwater are generally stable and not increasing over the life of the monitoring program. This indicates that this type of release is not occurring, and that even if there were a release of this type that was hypothetically ongoing, the data suggest that it would be at such a low level that natural processes are keeping hydrocarbon impacts in check and protecting the drinking water resource. These natural processes include the holding capacity of the basaltic bedrock, NSZD, and natural attenuation.

The Navy is committed to preventing any fuel release from the tanks to the environment, and therefore continues to identify and implement improvements to all aspects of the Red Hill Facility. There are also important naturally occurring processes that would effectively destroy small amounts of hydrocarbons if they were released into the environment. At Red Hill, a detailed environmental study of NSZD (McHugh et al. 2020; title and abstract shown below) was performed to actually measure the rate that nature is destroying the fuel from historical releases at the Red Hill Facility that is held above the groundwater by the lava rock's holding capacity. This study used two ways to prove that nature is destroying the spilled fuel, using technologies such as "carbon dioxide traps" and "heat flux measurements."



Contents lists available at ScienceDirect

Journal of Contaminant Hydrology

journal homepage: [www.elsevier.com/locate/jconhyd](http://www.elsevier.com/locate/jconhyd)



## Direct aerobic NSZD of a basalt vadose zone LNAPL source in Hawaii

Thomas McHugh<sup>a,\*</sup>, Charles Newell<sup>a</sup>, Brian Straser<sup>a</sup>, Curtis Stanley<sup>a</sup>, Jeff Johnson<sup>b</sup>,  
Thomas Henderson<sup>b</sup>, Douglas Roff<sup>c</sup>, Joel Narusawa<sup>d</sup>

<sup>a</sup> GSI Environmental Inc., Houston, TX, USA

<sup>b</sup> AECOM, Honolulu, HI, USA

<sup>c</sup> AECOM, San Diego, CA, USA

<sup>d</sup> NAVFAC HI, Honolulu, HI, USA



### ARTICLE INFO

#### Keywords:

Aerobic  
Biodegradation  
LNAPL  
Basalt  
NSZD

### ABSTRACT

In recent years, a number of methods have been used to measure the biodegradation of petroleum light non-aqueous phase liquids (LNAPL) at petroleum release sites, a process known as natural source zone depletion (NSZD). Most commonly, NSZD rates have been measured at sites with unconsolidated geology and relatively shallow groundwater (< 50 ft. bgs, < 15 m bgs). For this study, we have used two methods (1. carbon dioxide flux measured using carbon traps and 2. heat flux based on subsurface temperature gradients) to measure NSZD rates at a petroleum release site in Hawaii with basalt geology and deep groundwater (> 300 ft. bgs, > 100 m bgs). Both methods documented the occurrence of NSZD at the facility and the two methods yield estimates of the NSZD rate that agreed within a factor of 2 (4600 to 7400 gal/yr; 17,000 to 28,000 L/yr for the flux method and 8600 to 13,000 gal/yr; 33,000 to 49,000 L/yr for the temperature method). Soil gas samples collected directly above the water table and at shallower depths within the vadose zone indicated aerobic conditions throughout the vadose zone (oxygen > 13%) and no detectable methane. These results indicate that NSZD occurs at this site through the direct aerobic biodegradation of LNAPL rather than the two-step process of anaerobic methanogenesis followed by methane oxidation at a shallow depth interval documented at other sites.

The scientific work presented in this peer-reviewed paper accepted for publication in a leading scientific journal paper indicated that at least 4,600 gallons, and potentially as much as 13,000 gallons, of hydrocarbons under the tanks from historical release is currently being destroyed each year by naturally occurring fuel-consuming bacteria in the rocks and soil beneath the tanks. This process is called “biodegradation.”

The findings of this study were used to estimate the size of a small undetected hypothetical release that could be balanced by this natural destruction process. This analysis indicated that

the naturally occurring bacteria could prevent a release under 2,300 gallons per year (6.3 gallons per day) from reaching groundwater. If a fuel release were to continue beyond this amount, additional hydrocarbons would enter the fractured rock below the tanks, but at the same time, the naturally occurring bacteria would be removing the same amount. In other words, if there was a release of 2,300 gallons per year, the amount of the release would be balanced by the destruction facilitated by the naturally occurring bacteria. While there is uncertainty in any scientific calculation, the

measurements collected at the site confirm what has been observed to occur at every other hydrocarbon fuel release around the world: nature is able to destroy petroleum hydrocarbons at various rates.

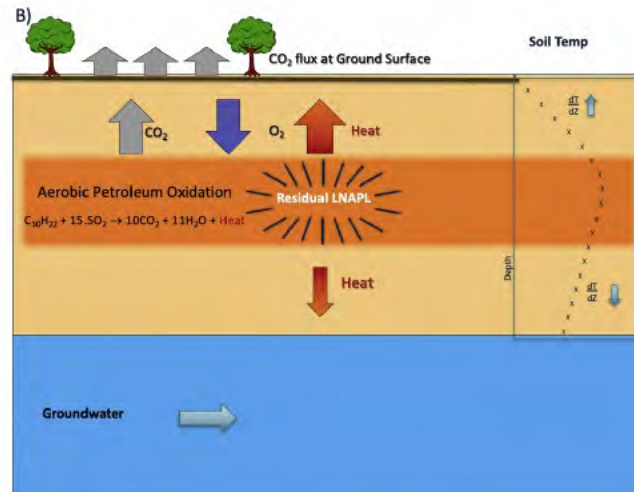

An analysis of NSZD and holding capacities for the basalt underlying Red Hill has been ongoing for several years and is most recently documented in the Red Hill *Investigation and Remediation of Releases (IRR) Report* (DON 2020b), which is currently under review by the Red Hill Administrative Order on Consent (AOC) Regulatory Agencies. If a small release from a tank were to occur and persist undetected by either AFHE/ATG, manual trend analysis, tank tightness testing, SVM, or other release detection methods being employed, the fuel would travel through the fractures and other geologic media below the tanks. The exact path of any hypothetical release is difficult to know precisely, but the general behavior is expected to encompass a footprint beneath the tanks.

Based on the results of the 2014 Tank 5 release, it is clear that SVM is effective for release detection. If a slow continual release occurred below the capabilities of tank tightness testing, it is likely that the vapors produced by the fuel would be detected by the SVM system. Because the released fuel is volatile and produces hydrocarbon vapors, the fuel does not have to come in contact with one of the vapor monitoring probes to be registered by the SVM system. The vapor “cloud” in the fractured rock (basalt) would be much larger than the footprint of the released fuel, making the vapor monitoring system a powerful tool for detecting any hypothetical releases. This is especially true because of the extremely porous nature of the volcanic rock subsurface of Red Hill, which readily transmits vapors. Moreover, the Navy continues to investigate additional improvements, and is planning to conduct a continuous soil vapor monitoring (CSVM) pilot test (see Response to RFI 10). If successful, implementation of a Facility-wide CSVM system will significantly enhance the ability of the system from a release detection standpoint by providing a means to more rapidly detect a release as well as the ability to potentially detect smaller releases. Thus, CSVM has a strong potential to detect even smaller releases that may be below the current detection capabilities, should they occur. The use of potential trigger points and associated actions are discussed in more detail in the Response to RFI 9.

Larger hypothetical releases were also evaluated (most recently in the IRR Report). These releases can be held in the basalt (holding capacity) to some degree, but could potentially exceed the NSZD rate. The released fuel could travel downwards and sideways, following the geologic dip (the angle that the lava that forms the basalt was flowing in geologic time).

The Navy's technical experts concluded that the January 2014 Tank 5 release of 27,000 gallons of fuel did not reach groundwater approximately 100 feet below the bottom of the tanks and was held in the various basalts beneath the tanks. The estimated "Reasonably Conservative and Protective Mid-Range Volume" that can be held in the fractured rock and soils before the fuel migrates to groundwater was estimated to range between 88,000 and 150,000 gallons. As an additional conservative assumption that basalt beneath the tanks has residual fuel (thus reducing the holding capacity), a correction of 25% should be made. This then reduces the estimated holding capacity to between 66,000 and 112,500 gallons.

In the event a hypothetical release of fuel did reach the groundwater, the hydrocarbon mixture would pool around the area where it reached the groundwater, and, depending on a host of factors, could potentially spread out near the top of the water table. This is similar to (but not the same as) pouring a little cooking oil on top of water in a bowl: the oil will spread out on top of the water. However, because the fuel is spreading out in the fractures and pores of the rock and soils near the top of the groundwater, the solid soil matrix would hold the material similar to a sponge, such that the spread would be limited. In addition, if some petroleum hydrocarbons did reach groundwater, a small fraction of the chemical constituents would dissolve into the water and potentially flow with the groundwater.

Therefore, as an additional line of defense related to release detection, the Navy has constructed a series of groundwater monitoring wells in the regional groundwater aquifer, allowing for sampling and monitoring conditions in the groundwater. The Navy continues to increase the number of wells in the Red Hill groundwater monitoring network on an ongoing basis. Groundwater monitoring wells near the fuel storage tanks are evaluated monthly for the presence of petroleum product (light nonaqueous-phase liquid [LNAPL], which floats on top of the water table). Of considerable significance, no amount of LNAPL has been measured on the groundwater surface in any well since gauging began in 2005, including during increased frequency of gauging after the 2014 release. In addition, all groundwater monitoring wells in the network are sampled and analyzed on at least a quarterly basis for the presence of chemicals of concern. If either LNAPL or the chemicals of concern at concentrations exceeding regulatory or other screening criteria are detected, additional actions are taken, which may include a detailed evaluation of the laboratory data, additional sampling, and comparison to results of the other release detection methods and data to ensure that potential releases are identified and dealt with. Therefore, even if fuel reached groundwater, this groundwater monitoring system has the ability to detect the actual fuels on the water table, should any occur, as well as the nature and extent of dissolved fuel constituents in groundwater.

In addition to the naturally occurring holding capacity and NSZD described above as a natural mitigation measure, dissolved fuel constituents in groundwater are also subject to biodegradation as a natural mitigation measure.

If LNAPL did reach groundwater, then some of the chemicals will dissolve out of the fuel and into groundwater. If this groundwater was in the vicinity of the tanks, it would flow toward Red Hill Shaft. Fortunately, there are naturally occurring bacteria that can destroy these chemicals, similar to the NSZD process. When this process occurs in groundwater, it is called “natural attenuation,” and the method for evaluating it is known as “monitored natural attenuation,” which is recognized by all regulatory agencies.

Natural attenuation is a well-understood process, with entire books written about it (Wiedemeier et al. 1999; cover at right) and with detailed guidance developed by environmental regulators like the Environmental Protection Agency (EPA) (EPA 1999), which has indicated that natural attenuation is a viable remediation method that can effectively meet remediation objectives that are protective of human health and the environment.

This natural attenuation process is occurring now at the Red Hill Facility. Currently, three groundwater monitoring wells located below the fuel storage tanks (RHMW01, RHMW02, and RHMW03) detected and still exhibit dissolved hydrocarbon impacts that were caused by historical releases from the tanks that occurred sometime before 2005. This demonstrates that the groundwater monitoring network is doing the job it was designed to do. In addition, Navy studies indicate that groundwater impacts from past releases are confined to the area beneath the tanks, and neither perimeter groundwater monitoring wells or any water supply well (e.g. Red Hill Shaft) have been impacted from fuel constituents from past releases, due to natural attenuation as described below.

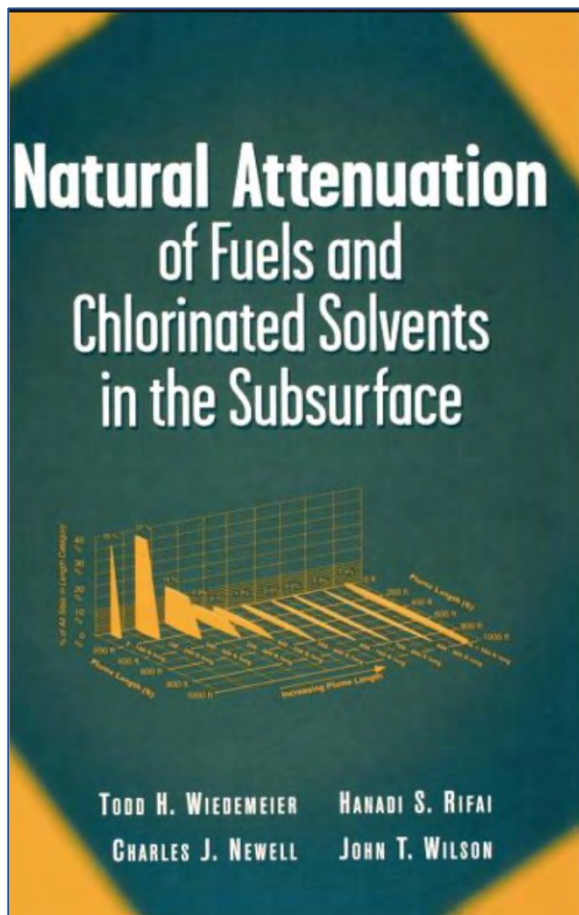

The IRR Report (DON 2020b) describes a range of mitigation measures that address both the 2014 27,000-gallon release from Tank 5 as well as a hypothetical large release of 120,000 gallons with the potential to impact groundwater. As described in the IRR Report, a combination of NSZD and natural attenuation are currently mitigating existing subsurface contamination. The Navy will continue to conduct environmental monitoring to ensure that these natural mechanisms continue to effectively mitigate existing impacts.

With respect to a hypothetical large future release (as opposed to a minor release), the Navy has conducted groundwater flow modeling to evaluate the potential use of the Navy’s Red Hill Shaft to create a “capture zone” that would contain potential impacts (DON 2020a). All the various models indicate that Red Hill Shaft can create an effective capture zone beneath the tanks when



pumped at its permitted rate. More details about the capture zone results based on current groundwater flow modeling efforts are described in the Response to RFI 1.

Should a very large hypothetical future releases impact groundwater beneath the tanks, however unlikely that would be, a capture zone can be induced by pumping Red Hill Shaft, as shown below. With the establishment of a capture zone, impacted groundwater can be prevented from migrating further, extracted, and treated to safe levels with well-established and reliable remediation system such as air sparging and granulated activated carbon, similar to systems the Honolulu Board of Water Supply has long used to safely treat some of its drinking water wells on Oahu.

Understanding capture zones (i.e., source water zones) is a key element of the Navy's groundwater modeling effort under the AOC. These zones describe the areas in the model area where water can flow to Red Hill Shaft and/or the Board of Water Supply's Halawa Shaft when these drinking water supply wells are pumping at permitted rates.

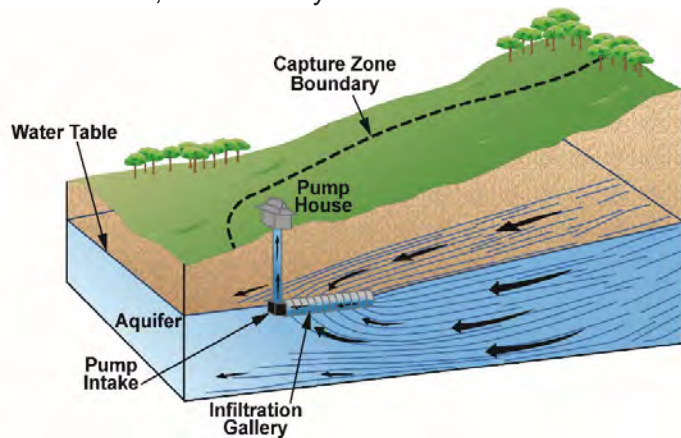

*A capture zone created by pumping a well*

Such understanding of the capture zone created by Red Hill Shaft, even when Halawa Shaft is pumping, has helped to determine:

- When operating at or near its permitted capacity, Red Hill Shaft can contain potential contaminant migration from beneath the tank farm.
- Where contaminants may potentially flow if Red Hill Shaft were not pumping.
- Estimated ranges of groundwater travel times.

This information is critical to decision making as well as to the development of remedies for hypothetical future petroleum releases that the Navy evaluated in its AOC Statement of Work (SOW) Section 6 IRR Report (DON 2020b) (currently under review by the AOC Regulatory Agencies). In the report, Red Hill Shaft was selected as the key receptor of concern because:

- All current groundwater flow models indicate that shallow groundwater beneath the tank portion of the Red Hill Facility is within the capture zone of Red Hill Shaft (when Red Hill Shaft is pumping at its permitted rate).

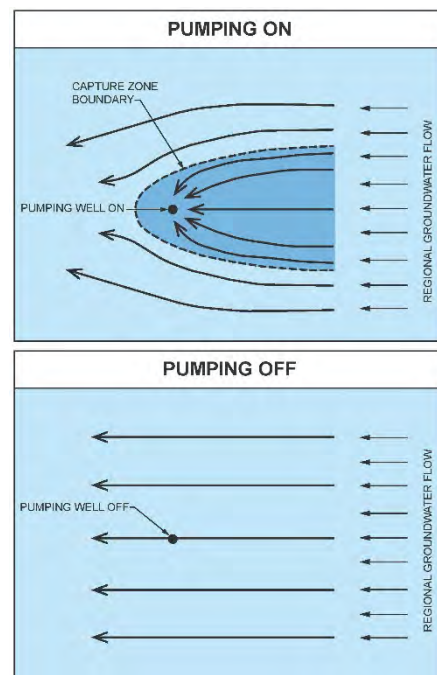

- Groundwater flow rates from the tank farm to Red Hill Shaft are conservatively estimated to be in the range of weeks to months (or longer under some scenarios).

Potential contaminant flow in groundwater under various hypothetical scenarios will be evaluated as part of the Navy's forthcoming contaminant fate and transport modeling effort under the AOC.

The Navy has initiated the process of requesting funds to construct a water treatment plant at Red Hill that will allow for continued pumping needed to create a groundwater capture zone. This process began with the development of a Primary Readiness Index (PRI) #0 DD 1391<sup>11</sup> planning document submitted as a request for funding to Navy senior leadership. The request for funding was denied at least until such time as EPA and the Hawaii State Department of Health (DOH) approve the concept of the Red Hill Shaft capture zone under the AOC. If approval is obtained, a PRI#1 DD 1391 will be updated and submitted following completion of the National Environmental Policy Act process as well as completion of a utilities study for the Red Hill Shaft water treatment plant. Only after these steps are completed will the project be eligible for future funding by Congress.

<sup>11</sup> A "DD Form 1391" is a submittal used by the Department of Defense to submit requirements and justifications in support of funding requests for military construction to Congress.

## Response to RFI 13: Significance of Hypothetical Slow Releases

### **Regulatory Agencies' Comment:**

#### **Significance of Slow Chronic Fuel Seepage Below the Tank Tightness Testing Threshold is not Addressed**

The Navy's release detection testing demonstrated that commercial technologies exist that can detect releases at rates as low as 0.5 gallons per hour or 4380 gallons per year. The release that occurred in 2014 was much larger than this, with a loss of about 27,000 gallons in a month or an average rate of around 37 gallons per hour. Along with the tank tightness testing on a periodic basis, other information that allows for detection of leaks includes the near continuous inventory monitoring system along with periodic soil vapor measurements.

However, even with all these release detection systems, slow chronic leaks can go undetected. This concern is most significant with single-wall systems. The Decision Document does not adequately analyze the significance of this concern and describe the potential environmental consequences of this limitation and potential mitigation measures.

### **Navy Summary Response:**

Over the course of more than 10 years of testing, each active Red Hill tank has consistently passed every single tank tightness test conducted, meeting the regulatory detection levels set by the Environmental Protection Agency (EPA) and the Hawaii State Department of Health (DOH) for all such underground storage tanks (USTs). The Navy conducts tank tightness tests twice a year, or double the standard established by state and federal requirements. In addition to adhering to federal and state detection level for tank tightness testing at a rate of 0.5 gallons per hour (gph), the Navy also currently employs six additional release detection methods (outlined briefly below and discussed in detail in the Navy's Response to RFI 6) that also suggest the storage tanks at the Red Hill Facility are tight. While it is conceivable that any tank system may be susceptible to small chronic releases at rates below detection levels, the cumulative data from the Red Hill Facility's release detection systems indicate that this is not taking place.

The significance of hypothetical slow releases and other scenarios are analyzed in broad terms below, and in greater detail in the Response to RFI 12. The Response to RFI 14 further describes how natural and other processes have ensured and will continue to ensure that potential environmental consequences related to small releases are mitigated. This is also discussed in more detail below.

## **Navy Detailed Response:**

### **The Red Hill Tanks Have Consistently Passed Every Tank Tightness Test at the Regulatory Detection Levels Set by EPA and DOH, and All Other Release Detection Systems Also Indicate the Tanks Are Tight.**

The Navy consistently adheres to EPA and DOH regulations for release detection as applied to USTs like the field-constructed tanks in use at the Red Hill Facility. These federal and state regulations were recently updated with respect to release detection, specifying that one successful tank tightness test on each operational tank be conducted each year with a detection level of “a 0.5 gallon per hour (gph) release rate.”<sup>12</sup>

The Navy currently satisfies (and exceeds) these federal and state regulations related to release detection at Red Hill. Since these detection levels were established by federal regulators in 2015, every Red Hill tank that has been tested has passed every tank tightness test. As a demonstration of the Navy’s commitment to safeguard the integrity of the tanks, the Navy has self-imposed a requirement that all operational tanks undergo tightness testing not once, but twice every year.

In its preamble to the updated federal regulations, EPA explained that it “thinks these options,” including annual tank tightness testing for release detection, “are reasonable and will quickly detect releases when they occur” (80 Fed. Reg. 41595). DOH later adopted the same options for the state regulations. In Hawaii, the 0.5 gph detection level for tank tightness testing applies equally to all field-constructed tanks in the state, large and small. Generally, tank owners and operators are not required to assume that a tank is leaking at a level below the detection level when its tanks consistently pass all tightness tests. Nevertheless, the Navy performs additional tests and gathers additional data using other release detection systems that also indicate that the tanks are tight.

The Navy’s commitment to release detection extends beyond tank tightness testing. The Navy employs several additional proven release detection methods beyond that required by the regulations. As described in detail in the Response to RFI 6, the seven current release detection methods include: automated fuel inventory monitoring; daily visual inspections of each tank; manual fuel inventories reconciliation; semiannual tank tightness testing; soil vapor monitoring; groundwater monitoring; and pipeline visual inspection. Also, as described in the Responses to RFIs 5, 7, and 9, the Navy continues to investigate and test potential improvements to these systems. While it is conceivable that a small release can occur in *any* UST system, even those compliant with all the regulations, all the data collected from the various Red Hill release detection systems corroborate the tank tightness tests and indicate that the tanks are, by all indications, tight.

<sup>12</sup> 40 CFR § 280.252(d)(1)(i) and HAR § 11-280.1-43(1)(A)

## **The Potential for Small Chronic Releases and Natural Processes That Mitigate Any Such Releases Are Discussed in the Responses to RFIs 12 and 14**

While any tank system might conceivably be susceptible to small, chronic releases, the Navy has put in place multiple layers of protection at Red Hill. In responding to RFI 12, the Navy analyzes the potential magnitude of various release scenarios, including hypothetical small chronic releases.

Although the Navy has devoted substantial efforts and resources to upgrade and maintain release prevention systems that avoid fuel releases from tanks, there are data indicating that the potential magnitude of such hypothetical releases would be mitigated by naturally occurring processes (as described in the Response to RFI 12) that would immediately begin to destroy hydrocarbons that could be released into the environment during a small chronic release. These well-recognized processes include natural source-zone depletion in the well-aerated volcanic bedrock near the tanks, and the natural attenuation of impacts to the groundwater in the immediate vicinity of the tanks. These naturally occurring degradation mechanisms readily assimilate and degrade hydrocarbons, which act as a food source for bacteria.

As described in greater detail in the Response to RFI 14, the Navy has conducted several studies that have found that there was no conclusive evidence of impact to the groundwater as a result of the 2014 Tank 5 release. One of the studies quantifying the natural assimilative capacity of the environment was subjected for peer review and accepted for publication in a leading publication, the *Journal of Contaminant Hydrology* (McHugh et al. 2020). As a result of studies conducted pursuant to the Red Hill Administrative Order on Consent (AOC), the AOC Statement of Work Section 6.3 *Investigation and Remediation of Releases Report* (DON 2020b) concluded that the data indicate that natural attenuation is effectively mitigating all cumulative impacts from the entire history of operation of the Red Hill Facility. This report is currently under review by the AOC Regulatory Agencies. This research demonstrates that the environmental and drinking water data indicate that, even if the Red Hill Facility does have some hypothetical small chronic release that none of the detections systems have detected, this natural assimilative capacity of the environment in part explains why perimeter groundwater monitoring wells are not impacted and the Navy's Red Hill Shaft has remained safe and will remain safe as additional improvements are implemented.

Nevertheless, as discussed in the Response to RFI 16, the Navy has recommended a feasibility study for a potential water treatment system that may be employed as a backup fail-safe precautionary method.

This page intentionally left blank

## Response to RFI 14: Response Actions and Related Environmental Impact from a Significant Release

### **Regulatory Agencies' Comment:**

#### **Response Actions and Related Environmental Impact from a Significant Release is Needed**

The Decision Document, page 97 states, "*The early detection and mitigation of a Significant (Gradual) Release is critical for minimizing the overall volume and subsequent impact of any release. Currently, groundwater modeling suggests any Significant (Gradual) Release could eventually be treated at a Red Hill Shaft water treatment plant without posing risk to the public drinking water source.*" The document does not attempt to quantify potential volume of release based on release response measures but relies on a water treatment system at Red Hill to ensure available drinking water. Because of this reliance, the RD Decision Document should include specifics about the timeframe for evaluation, design, and construction of the water treatment system. If the Navy cannot proceed directly to design of a system, the Decision Document must adequately describe the uncertainty related to the ability to design and construct a treatment system that justifies the need for a feasibility study, and discuss the related impacts for not having a water treatment system in response to a release.

The Regulatory Agencies note that the degree of capture at Red Hill Shaft for a range of possible release scenarios has not yet been fully evaluated and remains unclear whether it is an adequate measure to prevent impact to other receptors.

### **Navy Summary Response:**

The Responses to RFIs 11 and 12 provide potential quantities of hypothetical releases under a range of hypothetical scenarios (as requested by the Agencies). The Red Hill Administrative Order on Consent (AOC) Statement of Work (SOW) Section 6.3 *Investigation and Remediation of Releases (IRR) Report* (DON 2020b) began the process of designing a water treatment system to potentially address a hypothetical large release. This water treatment system is not required based on existing conditions, but could be a standby system to protect drinking water should an unlikely very large release occur. The IRR Report identified important factors and well-proven technologies that could be employed. The primary uncertainty and barrier to proceeding with the design and installation for the standby treatment system is administrative approval. The Navy cannot ask Congress to fund this effort and conduct the necessary studies and eventual procurement until the effort is part of an approved solution under the AOC. Completed and approved groundwater flow modeling and fate and transport modeling can help address some other relatively minor and manageable technical uncertainties, which are discussed below.

## Navy Detailed Response:

The Response to RFI 11 provides quantitative estimates of a broad range of hypothetical release scenarios, including calculation of associated estimated response times and release volumes for small, medium, and worst-case releases. The Response to RFI 12 explains that the IRR Report (DON 2020b) conducted pursuant to the AOC, which is currently being reviewed by the AOC Regulatory Agencies, analyzes a range of potential mitigation measures that address both the actual 2014 release of 27,000 gallons of jet fuel from Tank 5 as well as a hypothetical large release of 120,000 gallons with the potential of impacting groundwater.

As to older historical releases (before 2005), impacts to groundwater are confined close to the tank farm, where the natural attenuation and bioremediation processes (natural source-zone depletion [NSZD], monitored natural attenuation, and the volcanic bedrock's holding capacity) are actively protecting the groundwater and preventing dissolved-phase chemicals from impacting perimeter monitoring wells or Red Hill Shaft or other water supply wells. Scientific studies conducted by the Navy (DON 2018b; 2019a; 2020b; 2020c) indicate that biodegradation and other natural attenuation processes are protecting the groundwater. The dissolved-constituent impacts are confined to groundwater near the fuel storage tanks and do not appear to be increasing over the life of the groundwater monitoring program. In terms commonly used in the environmental field, this means that the impacts are "stable," "attenuated," and not migrating toward any human or ecological receptors. Available data indicate that both the nearest Navy supply well and Honolulu Board of Water Supply wells remain safe. Therefore, the establishment of a capture zone and water treatment plant is not necessary for existing conditions.

As to hypothetical releases that could conceivably occur in the future, the analyses outlined in the Response to RFI 12 considered a range of release scenarios and associated environmental affects, summarized as follows:

1. Small chronic release: While the Navy's goal is to prevent all releases, data indicate that if small chronic releases were to develop, they would be naturally degraded by NSZD and will not impact groundwater.
2. Larger continued chronic releases or a large sudden release that exceeds the holding capacity of the Red Hill basalts: Due to the various integrated release prevention and release detection systems, and based on the available data, this is a highly unlikely event. If such a release were to reach the groundwater, there could be a localized impact to groundwater beneath the tanks. This is similar to what is currently being observed at Red Hill, where older releases (prior to 2005) resulted in localized groundwater impacts near the tank farm. Groundwater monitoring data indicate that these groundwater plumes are undergoing natural attenuation, are stable, will not migrate any further, and will not impact any drinking water supply wells.
3. Hypothetical large catastrophic release: No large catastrophic release has ever occurred at the Red Hill Facility and all the improvements being made and analyses being conducted are designed to prevent one from ever occurring. In this highly unlikely scenario, fuel (light nonaqueous-phase liquid [LNAPL]) and dissolved-phase fuel constituents would likely flow toward Red Hill Shaft at a rate and in a quantity that could vary depending on the nature, location, extent of the release, as well as other factors, such as supply well pumping rates.



Mitigation measures for this hypothetical scenario are discussed in the following section and are described in detail in the IRR Report (DON 2020b).

### **Evaluation, Design, and Construction of a Potential Water Treatment System**

The Navy developed the March 2020 AOC SOW Section 7.1 *Groundwater Flow Model Report* using a multimodel approach to evaluate the flow of groundwater from beneath the Red Hill Facility and to compute the source water zones (capture zones) of the Red Hill Shaft and Halawa Shaft drinking water supply wells under various geologic and pumping conditions. The modeling team used the multimodel approach (Ajami et al. 2006) to bound feasible conditions, some of which were analyzed to address regulator and other experts' recommendations and comments on previous and interim models. Based on various technical discussions with the AOC Regulatory Agencies and stakeholders, including groundwater modeling working group meetings involving a host of experts and stakeholders, the Navy evaluated, modified, and added to the initially developed 49 models to present 14 models in the *Groundwater Flow Model Report*, to account for uncertainty and model reasonably probable potential scenarios and conditions. By evaluating all these different potential conditions, the models cumulatively provide reasonably conservative and protective estimates of groundwater flow conditions. The analyses of all the models resulted in several important conclusions:

- All models indicated that groundwater from beneath the tank farm is captured by Red Hill Shaft when it is pumping at its regulatory-permitted pumping limit, such that the Navy can capture and manage hypothetical future releases if any were to reach the groundwater and extend beyond the tank farm. The travel time to Red Hill Shaft varied among the models and release scenarios, with several models estimating that groundwater flow beneath certain tanks could reach Red Hill Shaft in a matter of weeks to months.
- Certain models showed that if Red Hill Shaft were to stop pumping for a certain duration, there are potential groundwater flow pathways to drinking water sources such as Halawa Shaft. In those models, however, the groundwater travel time is relatively long, such that:
  - There is time for natural attenuation to decrease or eliminate potential impacts to drinking water (this will be analyzed and scrutinized by the Environmental Protection Agency [EPA] and the Hawaii State Department of Health [DOH] in future contaminant fate and transport modeling work that will be conducted in accordance with the AOC timeline).
  - In the worst-case scenario, there would be advance notice of the potential need to treat hypothetical dissolved fuel constituents at wells other than Red Hill Shaft, if necessary. Such treatment systems could be similar to the granular activated carbon treatment systems currently used by the Honolulu Board of Water Supply at other wells on Oahu, which are conventional systems that municipal water suppliers around the world successfully rely upon.

The groundwater flow model is expected to be updated upon receipt of comments from the AOC Regulatory Agencies and other stakeholders. Groundwater flow modeling is an important tool that helps to enhance the understanding of environmental conditions and the ability to make predictions and risk management decisions. The contaminant fate and transport modeling that

will be conducted after the groundwater flow models are approved is an important step in understanding risks associated with a range of hypothetical releases and developing potential contingency treatment systems.

### **Uncertainty Related to the Ability to Design and Construct a Treatment System Is Primarily Administrative**

In preparing the IRR Report (DON 2020b), the Navy has already begun the conceptual design of a treatment system. However, to complete the design and construct a treatment plant, the Navy would have to request funding from Congress. Importantly, the IRR Report concluded, based on all available environmental data, that the treatment system is not required to address current conditions, which do not pose a threat to drinking water, but is instead proposed to be available (essentially in standby mode) in case a hypothetical large release were to occur in the future. Therefore, in order to request funding from Congress to proceed with the design and construction of a treatment plant, the Navy would need approval of its recommendations under the AOC, including the current Best Available Practicable Technology (BAPT) proposal.

Once the administrative hurdle is overcome, however, the development of petroleum hydrocarbon treatment systems is a relatively straightforward process, as such constituents are amenable to treatment through systems such as oil/water separators, air stripping, and granulated activated carbon, which have been successfully employed elsewhere on Oahu and throughout the world. The following are some relatively minor points of uncertainty related to the design of a treatment system.

1. **Groundwater Flow.** As previously discussed, a multimodel approach was used to help bound potential groundwater flow conditions. Finalization of the groundwater flow model (with input from the Regulators and other stakeholders) is an important step in further reducing uncertainty related to groundwater flow. Additional field studies are currently being discussed that may also help to reduce uncertainty regarding groundwater flow.
2. **LNAPL Migration.** Over the past several years, the Navy and the AOC Regulatory Agencies have held discussions pertaining to LNAPL flow modeling. This modeling effort would help to understand how LNAPL would migrate in the unsaturated and saturated zones due to a range of release scenarios. In addition, this modeling effort would provide a timeframe for how quickly LNAPL may migrate under those release scenarios. Finally, the modeled extent of LNAPL resulting from various release scenarios would serve to delineate potential source zones used in future fate and transport modeling.
3. **Contaminant Fate and Transport Modeling.** Since fuel hydrocarbons are attenuated and biodegraded in the environment, dissolved-phase constituents migrate at a lower velocity relative to groundwater and concentrations typically decrease and become stable over certain distances depending on various factors. The AOC SOW Section 7.2 contaminant fate and transport modeling effort that will be conducted once the groundwater flow model is approved

will provide a more detailed understanding of how fuel constituents may migrate over time and distance, which could impact system design.

Once these analyses are completed and concurrence is received for this approach, the preliminary details related to the design and cost of a proposed water treatment system that are described in the IRR Report (DON 2020b) can be refined. These types of treatment systems are in use at thousands of sites across the world, and the ability of these treatment systems to effectively treat fuel constituents in water is well known and would not require a pilot testing program. Various evaluations of potential water treatment aspects of a Red Hill Shaft capture zone have been completed, with the most recent evaluation included in the IRR Report (DON 2020b).

The Navy has initiated the process of requesting funds to construct a water treatment plant at Red Hill that will allow for the continued pumping needed to create a groundwater capture zone and the ability to treat any impacted water to all state and federal drinking water standards. This process began with the development of a “DD Form 1391”<sup>13</sup> planning document submitted as a request for funding to Navy senior leadership. The project cannot be funded until the AOC Regulatory Agencies approve the concept of the Red Hill Shaft capture zone as part of the recommended Tank Upgrade Alternative (TUA) under the AOC. If approval is obtained, the next step would be a revised submittal of a DD 1391 following completion of the National Environmental Policy Act process, as well as completion of a utilities study for the Red Hill Shaft water treatment plant. Only after these steps are completed will the project be eligible for future funding by Congress.

### **Potential Impacts of No Water Treatment System Availability**

The data confirm that no such treatment facility was required by the 2014 Tank 5 release. Under existing conditions, as long as catastrophic large-scale releases or other large releases that exceed the assimilative capacity of Red Hill do not occur (which is the purpose of the AOC and the reason for the substantial amount of work being conducted and costs being expended by the Navy), there would be no negative impacts if a treatment facility is not built.

In the highly unlikely event that a very large or catastrophic release were to occur, potential impacts to groundwater would depend on the quantity, nature, and location of the hypothetical release, and is therefore somewhat uncertain. In such a hypothetical scenario, Red Hill Shaft would likely be impacted. If LNAPL product reached the well and there were no treatment system, the pumps would have to be shut down. This in turn would result in a loss of the Red Hill water capacity for supply to Joint Base Pearl Harbor-Hickam, as well as the loss of capture provided by pumping Red Hill Shaft. In addition, depending on the size of a release, a dissolved-phase hydrocarbon plume might migrate off site, as described in the particle track analyses presented in the *Groundwater Flow Model Report* (DON 2020a). Potential aspects related to this are clearly

<sup>13</sup> A “DD Form 1391” is a submittal used by the Department of Defense to submit requirements and justifications in support of funding requests for military construction to Congress.

described in the report, where approximately half of the models used as part of the multimodel approach indicated that groundwater flow could potentially travel in the direction of the Halawa Shaft municipal supply well. None of the model simulations indicated potential flow toward the municipal Moanalua Valley supply wells. However, this represents only the groundwater flow, not the flow of hypothetical contaminants. Therefore, the contaminant fate and transport model will evaluate how far and how fast contaminants may migrate under a range of hypothetical release scenarios. This effort cannot be completed until the groundwater flow models are approved. Nevertheless, even the flow models alone indicate that there would very likely be enough time to implement a water treatment system at other wells such as Halawa Shaft, if needed.

Finally, a holistic risk assessment is being considered that will evaluate the probability of potential release scenarios, as well as the environmental risk associated with those releases. This analysis cannot be completed until groundwater flow models are approved and the contaminant fate and transport modeling is finalized. Finalization of this assessment will provide a tool to help facilitate management decisions moving forward.

## Response to RFI 15: Expanded Navy Red Hill Website

### **Regulatory Agencies' Comment:**

#### **Increase Transparency of Data Related to Release Detection to Build Greater Public Confidence in the Operational Integrity of the Red Hill System**

Navy should consider publishing data on groundwater monitoring and release detection on their website on an ongoing basis to increase transparency to build public confidence.

### **Navy Summary Response:**

The Navy embraces data transparency related to groundwater monitoring and release detection. Access to this information will help build greater public confidence in the operational integrity of the Red Hill Facility. The data show that every tank at the Facility has consistently passed tightness tests, demonstrating that the Red Hill Facility remains protective of the drinking water resource. Since transparency is key to building trust with stakeholders, including federal and state agencies and the public, the Navy is updating and expanding its current website to provide easy access to all the data already available to the public. The updated website will provide links directly to relevant information on websites that currently host the information (e.g. EPA, Hawaii State Department of Health, or the Navy), and will be continually updated to add any future products of interest with the objective of further increasing public awareness. In addition to the reports and data released to the regulators, the Navy's Red Hill Facility webpage includes additional information on community outreach efforts (such as public workshop, audio casts and stakeholder letters), Facility fact sheets, press releases and media coverage related to the Facility. The website also includes documents of interest, such as water quality reports, and a photo and video gallery.

The web site can be found here: <https://www.cnrc.navy.mil/regions/cnrh/om/red-hill-tank.html>.

### **Navy Detailed Response:**

The public has always had access to groundwater and soil vapor monitoring data. This information has consistently been included in publicly available reports. Additionally, the Administrative Order on Consent (AOC) Regulatory Agencies have direct access to all Facility data, which have been published on multiple websites. To consolidate this wide range of information into a central location that will enhance public access to information, the Navy will publish all relevant groundwater monitoring and release detection reports on its Red Hill Facility website.

As described below, the reports and data to be published for public access will include data that have always been publicly available (e.g., groundwater monitoring reports, soil vapor monitoring reports, oil/water interface reading tabulations, and drinking water quality reports), but other relevant information, data, and reports. Examples of this information include release detection reports, environmental reports set forth in the Administrative Order on Consent (AOC), and annual

and semiannual release detection testing reports. A summary description of each published report will be provided to explain the report's key findings. Any necessary redactions will be done in accordance with current Freedom of Information Act (FOIA) guidance. Every effort will be made to provide as much data as possible.

The reports and data published on the Navy's updated and expanded website will include the following, at minimum:

1. Soil Vapor Monitoring (SVM) Reports
2. Oil/Water Interface Monitoring Reports
3. Groundwater Monitoring Reports
4. Tank 5 Quarterly Release Response Reports
5. Drinking Water Monitoring Results
6. Annual Water Quality Reports
7. Release Detection Reports

In addition to the above, to maximize public access to information, the updated and expanded Navy website will also provide public access to the following environmental reports, which are currently available from the AOC Regulatory Agencies' websites:

8. Conceptual Site Model (CSM) Report
9. Groundwater Flow Model Progress Reports
10. Groundwater Flow Model (GWFM) Report
11. Investigation and Remediation of Releases (IRR) Report

In addition to upgrading the Red Hill Facility website, the Navy has launched other initiatives to increase transparency and enhance public access to information. The Navy is working in partnership with the University of Hawaii to develop a Red Hill Facility video detailing the Facility's history, mission, goals, and modernization. This will provide a graphic representation to broaden the public's understanding of the importance of the Facility, and to recognize what the Navy is doing to maintain the integrity of the Facility while operating it in a manner that fully complies with regulatory requirements. The video is expected to provide an accurate historical and visual depiction of the Red Hill Facility that will be made available for public viewing and consumption.

The Navy's ongoing outreach efforts with regulatory agencies and public stakeholders extend beyond a revised website. Other activities include the quarterly public meetings which consist of bi-annual Fuel Tank Advisory Committee (FTAC) meetings, and bi-annual Navy public open house (due to the COVID-19 pandemic, Navy is producing updates using audio casts vice in-person public gatherings. The audio cast can also be found on the same Red Hill website).

All FTAC meetings are facilitated by Hawaii State Department of Health (DOH). An important component of these meetings is the Navy's update on the operation, maintenance and upgrades to the Red Hill Facility. These updates include progress toward compliance with the AOC, improved Red Hill Facility operating procedures, Red Hill's release detection programs, improvements to the Clean / Inspect / and Repair program, research and development efforts to

include secondary containment, updates to the Navy's partnership initiatives with the University of Hawaii, as well as other initiatives to help the Navy identify new and innovative solutions.

As a further indication of the Navy's commitment to transparency of operations at the Red Hill Facility, the Navy working with the Hawaii Department of Health, has increased the frequency of the FTAC meetings from an annual to a semiannual basis.

This page intentionally left blank



## Response to RFI 16: Navy's Strategy for Water Protection

### **Regulatory Agencies' Comment:**

#### **The Overall Strategy Needs to Provide a Fail-Safe Plan for Water Protection**

The overall objective of both DOH's and EPA's underground storage tank programs is to protect human health and the environment from releases at underground storage tank facilities. This is accomplished by requiring prevention, detection, and response systems. Our objective is to prevent all releases, but this is not always possible.

Given the importance of the aquifer below the Red Hill tanks as a major source of drinking water for Honolulu, the Navy needs to establish a contingency strategy to assure no impairment of drinking water quality and no disruption in drinking water availability. This fail-safe protection strategy should be presented in the TUA and Release Detection Decision Documents.

### **Navy Summary Response:**

The Navy's primary goal has always been to conduct operations at the Red Hill Facility in a safe and responsible manner, safeguarding the environment and protecting drinking water for every resident of Oahu. Every action the Navy has taken pursuant to the Red Hill Administrative Order on Consent (AOC) has been specifically designed and conducted to protect human health and the environment in general, and the drinking water supply in particular. This includes the long-term monitoring program, a variety of construction projects, advanced technological research, and other programs and initiatives. The Tank Upgrade Alternatives (TUA) Decision Document concludes that implementation of the Best Available Practicable Technology (BAPT) is the best strategy for drinking water protection. Currently that BAPT is Alternative 1A, along with other release prevention, detection, and mitigation strategies described in this TUA Supplement and a host of other documents and reports prepared under the AOC and other related programs. The overall water protection strategy detailed in the Response to RFI 1 includes the layers of protection and system-of-systems, which are described further below and represented by the risk management bow-tie diagram.

Decades of data confirm the drinking water in the area of the Red Hill Facility has been safe prior to the modern improvements implemented in accordance with the AOC. Nevertheless, the Navy has recommended evaluating the use of a capture zone and treatment plant as a "fail-safe protection strategy." All other improvements are designed to ensure that such a system (which exceeds all current federal and state environmental requirements) will never be needed. This Response to RFI 16 provides additional information regarding how the use of a capture zone and water treatment plant would protect drinking water in the highly unlikely event that a large hypothetical future release were to impact water supply sources.

## **Navy Detailed Response:**

This TUA Supplement provides greater in-depth analysis of key issues pertaining to the overall groundwater protection strategy, including:

- The basis for selection and environmental safety of the currently recommended BAPT alternative (Responses to RFIs 1, 2)
- Release Prevention Measures (Responses to RFIs 3, 4, 5)
- Release Detection System-of-Systems (Responses to RFIs 6, 7, 8, 9, 10)
- Release Response Measures (Responses to RFIs 11, 12, 13, 14)

The bow-tie diagram presented on RFI 1 Figure 1 *ties together* and visually describes the various layers of protection currently being used and being planned by the Navy for protection of groundwater and drinking water.

In addition to the currently recommended alternative and associated environmental protection measures, this TUA Supplement also describes the Navy's ongoing engagement with top subject matter experts in the State of Hawaii and U.S. mainland to evaluate potential improvements that may be appropriate for consideration in upgrading BAPT in future TUA decisions.

In addition to the currently recommended alternative and associated environmental protection measures, this Supplement to the TUA Decision Document also describes how the Navy's ongoing engagement with top subject matter experts in the State of Hawaii and U.S. mainland to evaluate potential improvements that may be appropriate for consideration in upgrading BAPT in future TUA decisions.

Additionally, the Navy is committed to the installation of secondary containment by July 15, 2045 (as further described in the Response to RFI 5). These measures and the considerable investments being made are in direct support of the Navy's goal of ensuring continued environmental protection.

### **Drinking Water Protection Strategy**

As illustrated on RFI 1 Figure 1 and further described in the Responses to RFIs 1 and 12, the possibility of a very large or catastrophic release (which data indicate has never occurred at the Red Hill Facility) is highly unlikely. Even if such a hypothetical release were to occur, the Navy's varied response actions, including following the *Red Hill Response Plan* (Appendix B) (CNRH 2020), use of oil pressure isolation doors, and various naturally occurring properties of basalt and groundwater (holding capacity, natural source-zone depletion [NSZD], and natural attenuation) would act together to reduce the consequence of such a release. In the unlikely event of a future release large enough to adversely impact drinking water, the Navy's Red Hill Shaft could be used to create a capture zone to prevent impacts from migrating to other drinking water supply wells and treat the extracted water. Current operating conditions, available data, continual ongoing improvements, and the Navy's commitment to updated BAPT cycles and eventual secondary

containment (when this capability becomes practicable) suggest that this component of a “fail-safe” protection system will never be needed.

As described in the following sections of this response, a water treatment plant at Red Hill Shaft would serve two related but distinct purposes: (1) to impose a hydraulic barrier capable of containing petroleum product or dissolved-phase constituents to prevent migration away from Red Hill toward other water supply wells, and (2) to ensure continued delivery of safe potable water through use of a water treatment system for Red Hill Shaft.

### **Description of the Capture Zone and Water Treatment System**

The creation of capture zones to contain groundwater impacts is a well-established technology to protect groundwater.<sup>14</sup> As part of plans to address responses to any possible future release of product like those described earlier, the Navy has conducted groundwater flow modeling to evaluate potential use of the Navy’s Red Hill Shaft as a “capture zone” to contain potential impacts (DON 2020a). Although this model is still under review by the AOC Regulatory Agencies, and modifications to the models may be made under the AOC process, every model the Navy is evaluating indicates that Red Hill Shaft can create an effective capture zone beneath the tanks when pumped at the permitted rate. Should a hypothetical release large enough to impact the groundwater beneath the tanks occur, a capture zone can be induced by pumping Red Hill Shaft, as shown below. With the establishment of a capture zone, impacted groundwater can be prevented from migrating further, and can be extracted and treated to safe levels with a well-established and reliable water treatment system, such as air sparging or granulated activated carbon. These are similar to systems long used by the Honolulu Board of Water Supply to safely treat some of its drinking water wells on Oahu.

Understanding capture zones (i.e., source water zones) is a key element of the Navy’s groundwater modeling effort under the AOC. These capture zones describe the regions in the model area where water can flow to Red Hill Shaft or the Board of Water Supply’s Halawa Shaft when these drinking water supply wells are pumping at their permitted rates. If not otherwise mitigated by natural attenuation, impacts in these areas could potentially flow toward these wells over certain periods of time (likely greater than 1 year

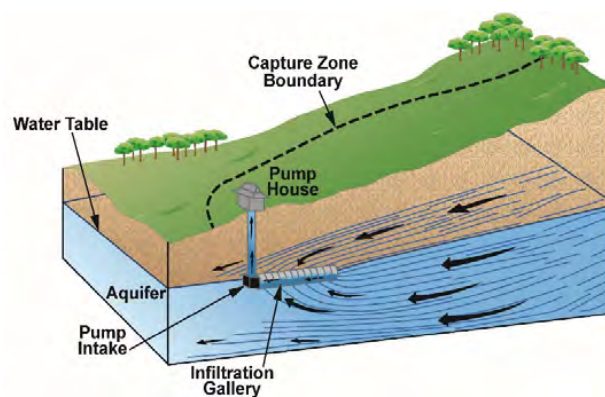

*A capture zone created by pumping a well*

<sup>14</sup> See, for example, EPA’s 2008 *A Systematic Approach for Evaluation of Capture Zones at Pump and Treat Systems*, which explains that “If a contaminant plume is hydraulically contained, contaminants moving with the ground water will not spread beyond the capture zone.” [https://cfpub.epa.gov/si/si\\_public\\_record\\_report.cfm?Lab=NRMRL&dirEntryId=187788](https://cfpub.epa.gov/si/si_public_record_report.cfm?Lab=NRMRL&dirEntryId=187788)

travel time, which is a suitable interval to formulate and implement a response, especially once sentinel wells are established as the AOC process progresses).

The understanding of the capture zone created by Red Hill Shaft, even when Halawa Shaft is pumping, has helped to determine:

1. When operating at or near its permitted capacity, Red Hill Shaft can contain potential contaminant migration from beneath the tank farm.
2. Where contaminants may potentially flow if Red Hill Shaft were not pumping.
3. Estimated ranges of groundwater travel times.

This information is critical to decision making as well as to the development of remedies for a hypothetical future petroleum release that the Navy evaluated in its AOC Statement of Work (SOW) Section 6.3 *Investigation and Remediation of Releases Report* (DON 2020b) (currently under review by the AOC Regulatory Agencies). In the report, Red Hill Shaft was selected as the key receptor of concern because:

1. All current groundwater flow models indicate that shallow groundwater beneath the tank portion of the Red Hill Facility is within the capture zone of Red Hill Shaft (when Red Hill Shaft is pumping at its permitted rate).
2. Estimated groundwater flow rates from the tank farm to Red Hill Shaft vary from several weeks to months or longer, depending on the scenario.
3. The municipal Moanalua Wells are not impacted from groundwater flow emanating from Red Hill under any of the scenarios evaluated.
4. If Red Hill Shaft is offline (i.e., not pumping), water from the tank farm may extend outside of the potential Red Hill Shaft capture envelope on the order of 3 months to 1 year. If Red Hill Shaft is restarted within this timeframe, the models show that impacts would be drawn back toward Red Hill Shaft and captured.
5. If Red Hill Shaft remained offline, water originating from the tank farm might reach Halawa Shaft on the order of 4.5 months to 1.5 years. However, these estimates of groundwater travel time do not represent hypothetical petroleum contaminant migration rates that normally travels slower than and not as far as groundwater, as described below.

Due to the attenuation (including biodegradation, absorption, and other natural processes) of fuel constituents dissolved in groundwater, migration of these constituents is much slower than groundwater migration rates. These impacts typically stabilize within hundreds of feet of a fuel source. Potential contaminant flow in groundwater under various hypothetical scenarios will be evaluated as part of the Navy's future contaminant fate and transport modeling effort under the AOC. This may help to further refine the potential capture zone and design of the treatment system, which is not required by existing conditions.

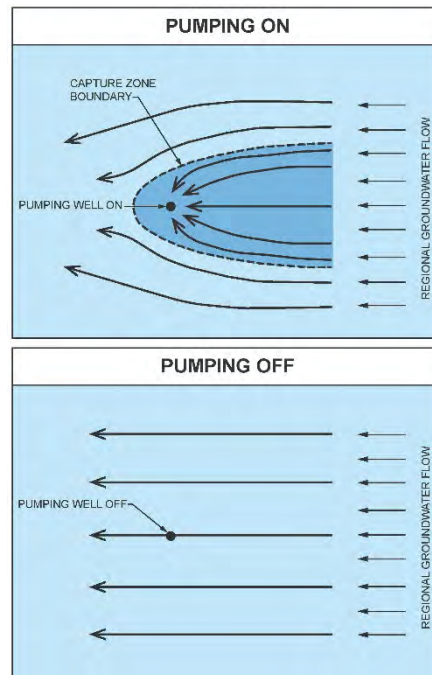

The Navy has initiated the process of requesting funds to construct a water treatment plant at Red Hill that will allow for the continued pumping needed to create a groundwater capture zone and the ability to treat any impacted water to all federal and state drinking water standards. This process began with the development of a “DD Form 1391”<sup>15</sup> planning document submitted as a request for funding to Navy senior leadership. The project cannot be funded until such time as the AOC Regulatory Agencies approve the concept of the Red Hill Shaft capture zone as part of the recommended TUA alternative under the AOC. With approval of both the groundwater flow model and this system as part of the recommended TUA alternative, the design and location of the treatment system may be able to proceed. Once approval has been obtained, the Navy will refine the system design and submit a revised DD 1391 following completion of the National Environmental Policy Act process and a utilities study for the Red Hill Shaft water treatment plant. Only after these steps are completed will the project be eligible for future funding by Congress.

### **The Capture Zone/Water Treatment Plant Is a Contingency Plan**

The annual water quality reports from both the Honolulu Board of Water Supply and the Navy continue to confirm the drinking water is safe for public consumption. In other words, the data clearly show that there is currently no need for drinking water treatment. The ongoing improvements currently being implemented by the Navy could result in the proposed water treatment plant never being needed. This is due in part to the capacity of the Red Hill basalts to attenuate fuel constituents (as repeatedly confirmed from annual drinking water quality reports) and the lack of appreciable impacts in the perimeter groundwater monitoring wells around Red Hill that the Navy continues to install. Data related to the 2014 Tank 5 release have consistently demonstrated that the release of 27,000 gallons did not impact the drinking water. Furthermore, the 2014 release was not the result of any failure related to the tanks or pipes. The release occurred as a result of human error while repairing a tank. The failure of this process was addressed and corrected by the Navy to ensure that similar errors will never be repeated. Even without the capture zone/water treatment plant, the layers of protection proposed in the TUA and Release Detection Decision Document more than adequately address the potential risks of a release (other than a very large or catastrophic release, which is highly unlikely) from Red Hill and continue to be highly protective of both the groundwater and drinking water resources.

### **Conclusion**

The bow-tie diagram presented on RFI 1 Figure 1 describes how all elements of release prevention, detection, and release response measures are fully integrated to protect groundwater and drinking water resources. All these elements are described in detail in the Responses to RFIs in this Supplement to the TUA Decision Document.

This analysis considered a range of potential threats relating to an inadvertent release, include corrosion and tank integrity, improper operations, improper return to service and tank filling

<sup>15</sup> A “DD Form 1391” is a submittal used by the Department of Defense to submit requirements and justifications in support of funding requests for military construction to Congress.

procedures, as well as nozzle failure. The diagram includes various release prevention barriers on each threat line. This demonstrates the steps the Navy is taking toward ensuring that potential releases are prevented from occurring. The diagram shows various release detection and response measures that minimize consequences to groundwater, should a release occur. The range of hypothetical consequences includes (1) impact to basalt (but not groundwater), (2) slight impact to groundwater, and (3) impact to groundwater and drinking water.

Each of these three consequences is also associated with a range of fuel releases that have been evaluated as part of various studies conducted by the Navy (as further described in the Response to RFI 12). Should a release occur, the release detection and release response barriers shown will help to reduce the consequence of a release for each of the three consequences described above. Release detection measures are shown in black. These measures not only exceed federal and state release detection requirements but work together so that any releases would be quickly discovered and the release volume minimized.

Finally, release mitigation measures are shown in gray. Various Navy studies describe natural processes including fuel retention in basalt, NSZD that degrades fuel retained in the basalt above groundwater, and natural attenuation that degrades fuel constituents that may impact groundwater. While it is the intent of the Navy to have zero releases, these naturally occurring mitigation measures help to minimize the impact to groundwater, due in part to how fuel naturally degrades in the environment. Taken together, the combination of release prevention, detection, and response measures demonstrate that groundwater is well protected and that the likelihood of any impact to drinking water is extremely small.

The Navy's goals remain firm: to protect the nation, the environment, and our drinking water.

# III Appendices

This page intentionally left blank



Appendix A:  
AOC SOW Section 5.4 Execution Plan, Decision on Need for and Scope of  
Modified Corrosion and Metal Fatigue Practices

This page intentionally left blank



**DEPARTMENT OF THE NAVY**  
COMMANDER  
NAVY REGION HAWAII  
850 TICONDEROGA ST STE 110  
JBP3H, HAWAII 96860-5101

5750

N4

21 DEC 2020

**CERTIFIED NO: 9489 0090 0027 6232 2381 63**

Mr. Steven Linder, P.E.  
U.S. Environmental Protection Agency Region IX  
75 Hawthorne Street  
San Francisco, CA 94105

**CERTIFIED NO: 9489 0090 0027 6232 2381 70**

Ms. Roxanne Kwan  
State of Hawaii Department of Health  
Environmental Management Division  
Solid and Hazardous Waste Branch  
2827 Waimano Home Road  
Pearl City, HI 96782

Dear Mr. Linder and Ms. Kwan:

**SUBJECT: ADMINISTRATIVE ORDER ON CONSENT STATEMENT OF WORK SECTION 5.4, CORROSION AND METAL FATIGUE PRACTICES, SCOPE OF WORK MODIFIED CORROSION AND METAL FATIGUE PRACTICES, RED HILL BULK FUEL STORAGE FACILITY, JOINT BASE PEARL HARBOR-HICKAM, OAHU, HAWAII**

The Navy and Defense Logistics Agency (DLA) acknowledges receipt of the letter from the U.S. Environmental Protection Agency (EPA) and Hawaii Department of Health (DOH) dated 07 JUL 2020, concurring with the Navy's recommendation to proceed with Section 5.4 - Modified Corrosion and Metal Fatigue practices. The final scoping meeting was held on 19 NOV 2020 in which the Navy presented its plan to address all concerns articulated in the Destructive Testing Results Report letter from EPA/DOH dated 16 MAR 2020. Please find enclosed the Section 5.4 EXECUTION PLAN – Decision on Need for and Scope of Modified Corrosion and Metal Fatigue Practices for your review and approval. The Navy would greatly appreciate an expeditious review and approval of this execution plan so work can begin without a delay.

If you have any questions, please contact Mr. Donald Panthen, the Red Hill Program Director/Project Coordinator at (808) 473-4148 or by email at donald.panthen@navy.mil.

Sincerely,

J. G. MEYER  
Captain, CEC, U.S. Navy  
Regional Engineer  
By direction of the  
Commander

21 DEC 2020

- References:
1. Letter to CAPT Delao from Mr. Linder and Ms. Kwan dated July 7, 2020, Re: Regulatory Agency Response to Navy Letter Acknowledging Agency Disapproval of the Navy's Corrosion and Metal Fatigue Practices, Destructive Testing Results Report, Red Hill Bulk Fuel Storage Facility (Red Hill), Joint Base Pearl Harbor-Hickam, Oahu, Hawaii.
  2. Letter to CAPT Delao from Mr. Linder and Ms. Kwan dated March 16, 2020, Re: Response to Corrosion and Metal Fatigue Practices, Destructive Testing Results Report, Red Hill Bulk Fuel Storage Facility (Red Hill), Joint Base Pearl Harbor-Hickam, Oahu, Hawaii
- Enclosure:
1. Navy/DLA Proposed Section 5.4 EXECUTION PLAN – Decision on Need for and Scope of Modified Corrosion and Metal Fatigue Practices

Administrative Order on Consent  
In the Matter of Red Hill Bulk Fuel Storage Facility  
EPA Docket No: RCRA 7003-R9-2015-01  
DOH Docket No: 15-UST-EA-01

**Section 5.4**  
**EXECUTION PLAN**  
**Decision on Need for and Scope of Modified Corrosion and Metal**  
**Fatigue Practices**

Prepared by:  
NAVFAC EXWC

DATE: 4 December 2020

This Page is Intentionally Left Blank.

## **EXECUTIVE SUMMARY**

The purpose of AOC Section 5.4 is to improve the current inspection process as stated in the AOC SOW Section 2.4 Tank, Inspection, Repair and Maintenance (TIRM) Decision Document, dated 24 April 2017. The agreed upon goal, by the Regulatory Agencies (RAs) and Navy/DLA (Defense Logistics Agency) for an improved TIRM process, is to achieve no release during the service interval between Clean, Inspect, and Repair (CIR) events. Improvements will focus on significant and practicable opportunities to increase confidence in achieving TIRM performance goal.

This report provides the execution plan for the Navy/DLA for the preparation of documents to respond to RAs letters regarding previous work and deliverables under AOC Section 5.3. The Navy will provide documents that will consist of additional research, studies, data, information, investigations, and recommendations. The intent of the documents is to clarify, explain, amplify, and present new information both in furtherance of responses related to AOC Section 5.3 as well as implementation of AOC Section 5.4.

This Page is Intentionally Left Blank.



**TABLE OF CONTENTS**

ACRONYMS AND ABBREVIATIONS ..... vi

1.0 INTRODUCTION ..... 1

2.0 DOCUMENT #1 – NAVY/DLA INTERPRETATION OF THE COUPON RESULTS ..... 3

3.0 DOCUMENT #2 – PRELIMINARY LINER CORROSION ASSESSMENT REPORT (PLCA) ..... 4

4.0 DOCUMENT #3 – PRELIMINARY CONCRETE ASSESSMENT REPORT ..... 5

5.0 DOCUMENT #4 – INSPECT AND REPAIR PROTOCOLS PROJECT FOR RED HILL UNDERGROUND STORAGE TANKS ..... 6

6.0 DOCUMENT #5 – CONCRETE TANK DEGRADATION INSPECTION AND RETROFIT ..... 7

7.0 DOCUMENT #6 – ELEMENT, PHASE, AND OXIDATION STATE MAPPING OF RED HILL UST CORROSION BY ADVANCED MICROSCOPY METHODS..... 8

8.0 DOCUMENT #7 – INSPECTION DATA, LFET, AND STEP 2 ANALYSIS REPORT ..... 9

9.0 DOCUMENT #8 – ROBOTIC INSPECTION REPORT ..... 11

10.0 DOCUMENT #9 – TIRM UPDATE REPORT..... 12

11.0 DOCUMENT #10 - OVERALL CORROSION ASSESSMENT REPORT (OCA) (6.1)..... 13

APPENDIX A - AOC Section 5.4 Scope of Work Outline (1 September 2020) ..... A-1

APPENDIX B - Schedule ..... B-1

APPENDIX C - Contract Statement of Work – Provide Red Hill Corrosion Assessment ..... C-1

APPENDIX D - Contract Statement of Work – Access Reinforced Concrete Red Hill..... D-1

APPENDIX E - Proposal - Inspect and Repair Protocols Project for Red Hill Underground Storage Tanks .E- 1

APPENDIX F - Proposal - Concrete Tank Degradation Inspection and Retrofit..... F-1

APPENDIX G - Proposal - Element, Phase, and Oxidation State Mapping of Red Hill UST Corrosion by Advanced Microscopy Methods ..... G-1

This Page is Intentionally Left Blank

## **ACRONYMS AND ABBREVIATIONS**

ACI	American Concrete Institute
AOC	Administrative Order on Consent
BFET	Balanced-Field Electromagnetic Technology
DLA	Defense Logistics Agency
DTRR	Destructive Testing Results Report
HCL	Hawaii Corrosion Laboratory
MFE	Magnetic Flux Examination
NDE	Non-Destructive Examination
PAUT	Phase Array Ultrasonic Testing
PLCA	Preliminary Liner Corrosion Assessment Report
RAs	Regulatory Agencies
RHBFSF	Red Hill Bulk Fuel Storage Facility
SOW	Scope of Work
TIRM	Tank, Inspection, Repair and Maintenance
UH	University of Hawaii
UST	Underground Storage Tank
UT	Ultrasonic Testing

This Page is Intentionally Left Blank

## **1.0 INTRODUCTION**

### **1.1 Background**

The Navy/DLA submitted the *Corrosion and Metal Fatigue Practices, Destructive Testing Results Report* (DTRR) to the RAs on July 7, 2019 to satisfy the requirements in section 5.3.3 of the Red Hill Administrative Order on Consent (“AOC”). On March 16, 2020, the RAs provided their response to this report, in which they stated that they “do not concur that the “NDE results are validated, both by Destructive Testing and thorough, case-by-case analysis.” The RAs stated in their letter that additional work should include both 1) future effort to improve the non-destructive testing protocol as generally envisioned in Section 5.4 of the AOC SOW, and 2) further destructive testing to address deficiencies to evaluate proposed improvements to the non-destructive testing protocol.

Following the RAs’ letter disapproving the DTRR, discussions between the Navy/DLA and the RAs resolved many of the differences in interpretation. The Navy/DLA submitted a letter on June 2, 2020 to the RAs that agreed with the RAs that additional information to substantiate the DTRR conclusions is warranted. RAs conditionally approved the DTRR on July 7, 2020 under an agreement that the Navy/DLA will work to “identify and implement practicable improvements to the NDE process with the specific goal of defining performance objectives that are protective of human health and the environment.” Thus, the requirements to implement the AOC SOW Section 5.4 were met.

### **1.2 Section 5.4 Scoping Meetings**

Three scoping meetings were held between the Navy/DLA and the RAs: (1) July 13, 2020, (2) August 11, 2020, and (3) September 1, 2020. Attachment A is the final Scope of Work outline presented to the RAs on 1 September 2020.

### **1.3 Execution Plan**

The Navy/DLA has incorporated the Scope of Work outline (Attachment A) into ten (10) distinct Work Products. The development of the Work Products will include additional research, studies, data, information, investigations, and recommendations.

The numbers in parenthesis in each below Work Product correlate to the Scope of Work outline (Attachment A). The Navy/DLA is unable to provide specific planned contract documents that will be performed by Contractors, as this is Source-Selection privileged information.

## **1.4 Content**

In addition, the work products' content will address the following broad categories.

- 1) Technology – including Non-Destructive Examination (NDE) technology such as specific technologies and equipment to get optimal data within practicable limitations.
- 2) Human Factors (implementation of technology) – the overall Tank Inspection, Repair, and Maintenance (TIRM) process related to corrosion control is reliant on human performance. What can be done to limit or mitigate human factor errors?
- 3) Repair Threshold / Process / Criteria – Re-evaluate adequacy of current practice to determine if adjustments are needed to account for new information such as the destructive testing study and analysis on NDE limitations.
- 4) Slowing / Stopping Corrosion – Given lessons learned from NDE data, destructive testing, and others studies, what can be done (if anything) to slow or stop corrosion that is occurring?
- 5) NDE Comparison – How does Balanced-Field Electromagnetic Technology (BFET) NDE testing compare with other non-electronic NDE (such as vacuum testing or Magnetic Flux Examination (MFE)) methods to verify weld joint integrity?

## **1.5 Schedule**

The approximate schedule for the completion of the work is provided for each document. This schedule is based on Navy/DLA resources and realistic timeframes. However, these schedules are very dependent on COVID-19 work and travel restraints, therefore these schedules may be extended by several months. An overall estimated schedule for this entire effort is provided in Appendix B. A significant amount of additional content has been requested by the RAs during the Section 5.4 Scoping meeting. The development of some of the documents are based on results of antecedent reports and analysis. Other information will require original publication-grade research. Therefore, there will be multiple documents for the RAs to review. It is anticipated that limited preliminary document(s) may be available as within six (6) months of approval of this plan. Due to the amount of testing, research, and dependencies between the documents, the overall plan will require 1-1/2 to two (2) years to provide all of the documents.

## 2.0 DOCUMENT #1 – NAVY/DLA INTERPRETATION OF THE COUPON RESULTS

### 2.1 Purpose

- The RAs’ interpretation of the Destructive Testing Report was that there were two (2) False Positives and two (2) False Negatives.
- The RAs stated that Navy’s laboratory analysis did not or was unable to identify the thinnest portion of each plate which made the destructive testing exercise and its analysis incomplete.
- The RAs stated there is insufficient correlation between NDE and the laboratory measurements.
- The RAs stated a need for more discussion of the significance of field NDE results vs. laboratory results.
- This report will address the following topics in response to the RAs interpretation and statements submitted in their letter dated March 16, 2020.

### 2.2 Outline

1. [REDACTED]
- [REDACTED]
- [REDACTED]

### 2.3 Schedule

- November 2021 (refer to paragraph 1.5 above)

### **3.0 DOCUMENT #2 – PRELIMINARY LINER CORROSION ASSESSMENT REPORT (PLCA)**

#### **3.1 Purpose**

- The RAs stated a belief the Navy is underestimating corrosion rates for Tank 14 and should reassess corrosion rates used in calculating minimum remaining thickness under TIRM.
- Also, it was stated the potential cause for increasing corrosion rates creates concern for potential corrosion of embedded reinforcement in the concrete.
- The Navy/DLA will address the following topics in response to the RAs' statement.

#### **3.2 Outline**

1. Potential for Increased Rates of Corrosion
  - 1.1. Method by which Corrosion Rate is calculated (4.1)
  - 1.2. Using extreme value rates to establish Minimum Remaining Thickness (4.2)
  - 1.3. Environmental and chemical conditions affecting rates (4.4)
  - 1.4. Potential causes for corrosion (4.6)
  - 1.5. Potential corrosion impact from use of old versus new carbon steel Patch Plates (4.9)
    - 1.5.1. Potential Galvanic corrosion between new patch plate and old carbon steel liner (4.9.1)
2. Potential for weld stress due to crevice corrosion in the gap between the steel liner and a new patch plate. (4.9.2)
  - 2.1 Address crevice corrosion in fillet-welded patch plates on ASTs and how this is applicable for Red Hill and USTs in general.
3. Rainfall effects on Red Hill metal liners (4.7)
4. Factor of Safety (5.2)
  - Comparison with other industries (API, ASME, ASCE, etc.)
5. Corrosion Rates (5.3)
  - Address extreme value (e.g., timber lodged behind plate) vs uniform rate
  - Comparison of corrosion rate model used at Red Hill with API standards
  - Reevaluate the repair threshold and associated factor of safety to account for inaccuracies in NDE, corrosion rates, and possible delays in repair cycles.

#### **3.3 Schedule**

- July 2021
- Refer to paragraph 1.5 above



## **4.0 DOCUMENT #3 – PRELIMINARY CONCRETE ASSESSMENT REPORT**

### **4.1 Purpose**

Empirical evidence and a preliminary assessment of the Red Hill Bulk Fuel Storage Facility (RHBFSF) demonstrate the concrete is in good condition. Further information about the quality and durability of the RHBFSF concrete, and the potential for corrosion in the reinforcement is needed. The basis for this information is an analysis of mechanical, physical, and material properties. Due to characteristics of the facility and the potential for deleterious consequences of ad hoc destructive testing, a deliberate approach that will mitigate damage to the infrastructure is necessary.

### **4.2 Outline**

1. Conduct additional analyses on the condition of the concrete structure and embedded reinforcing steel. (5.4)
  - Study existing concrete pursuant to principles of American Concrete Institute (ACI) 364-1R-19 Guide for Assessment of Concrete Structures Before Rehabilitation
  - Cores might include embedded reinforcing steel
  - Physical, chemical, and mechanical properties of the concrete will be studied

### **4.3 Schedule**

- July 2021
- Refer to paragraph 1.5 above

## **5.0 DOCUMENT #4 – INSPECT AND REPAIR PROTOCOLS PROJECT FOR RED HILL UNDERGROUND STORAGE TANKS**

### **5.1 Purpose**

The RAs stated a belief the Navy is underestimating corrosion rates for Tank 14 and should reassess corrosion rates used in calculating minimum remaining thickness under TIRM.

### **5.2 Outline**

1. University of Hawaii (UH) Study - The Hawaii Corrosion Laboratory (HCL), Department of Mechanical Engineering proposes to 1) elucidate the limits of nondestructive evaluation on severely corroded steel panels with adherent corrosion products, 2) develop protocol to measure in situ corrosion rates of steel panels that can be used for the Red Hill USTs, and 3) evaluate repair and patch protocols to prevent premature failures. (4.3)
2. Peer Review of Report (Corrosion Consultant)

### **5.3 Schedule**

- November 2021
- Based on current UH schedule
- Refer to paragraph 1.5 above

## **6.0 DOCUMENT #5 – CONCRETE TANK DEGRADATION INSPECTION AND RETROFIT**

### **6.1 Purpose**

The RAs stated a belief that the potential cause for increasing corrosion rates creates concern for potential corrosion of embedded reinforcement in the concrete.

### **6.2 Outline**

1. UH Study - The objectives of this portion (secondary containment-corrosion in concrete) of the project are to 1) identify the locations and extent of cracking/degradation of the concrete and steel structure surrounding the oil tanks, 2) understand the causes and mechanism of the concrete and steel degradation based on chemical and mineralogical analysis, and 3) propose appropriate retrofitting technologies and strategies. (4.5)
2. Peer review of report – Concrete Consultant

### **6.3 Schedule**

- November 2021
- Based on current UH schedule
- Refer to paragraph 1.5 above

## **7.0 DOCUMENT #6 – ELEMENT, PHASE, AND OXIDATION STATE MAPPING OF RED HILL UST CORROSION BY ADVANCED MICROSCOPY METHODS**

### **7.1 Purpose**

Assess the possibility of distinguishing historic from contemporary corrosion episodes via “tracer” element and oxidation state distributions that may reveal episodic corrosion history and allow exclusion of one or more sources from consideration in water pathway.

### **7.2 Outline**

1. UH Study - Laboratory study to attempt to distinguish between recent and historic corrosion. The Advanced Electron Microscopy Center at UH will perform element, phase, and oxidation state mapping and analysis of coupons extracted from out-of-service Red Hill USTs, and in close collaboration with Task 2, laboratory-generated corrosion samples, as they are produced. These analyses will be carried out in a focused-ion-beam scanning electron microscope and a scanning transmission electron microscope using electron imaging, energy dispersive X-ray spectroscopy and electron energy loss spectroscopy to visualize structure, morphology, and corrosion product phases and distributions. (5.3.5)
2. Peer review of report by corrosion consultant

### **7.3 Schedule**

- August 2021
- Refer to paragraph 1.5 above

**8.0 DOCUMENT #7 – INSPECTION DATA, LFET, AND STEP 2 ANALYSIS REPORT**

**8.1 Purpose**

The following topics were developed during discussions with the RAs during previous Scoping meetings from 4 June 2020 to 11 August 2020. These topics will be addressed, analyzed, and discussed thoroughly by Navy/DLA. The Navy/DLA will provide this information and documentation to the RAs as they are developed.

**8.2 Outline**

1. [REDACTED]
- [REDACTED]
  - [REDACTED]
  - [REDACTED]
  - [REDACTED]
  - [REDACTED]
  - [REDACTED]
  - [REDACTED]
  - [REDACTED]
- [REDACTED]
  - [REDACTED]
  - [REDACTED]
  - [REDACTED]
  - [REDACTED]
  - [REDACTED]
  - [REDACTED]
- [REDACTED]
  - [REDACTED]
  - [REDACTED]

### **8.3 Schedule**

- May 2022??
- Delayed 6 – 12 months due to COVID-19. We are not allowed in the Lab to create the corrosion on the test plates.
- Refer to paragraph 1.5 above

## **9.0 DOCUMENT #8 – ROBOTIC INSPECTION REPORT**

### **9.1 Purpose**

Analyze the technology of robotic inspections and compare to a previously performed inspection using manual inspections.

### **9.2 Outline**

[REDACTED]

[REDACTED]

### **9.3 Schedule**

- June 2022
- Dependent on schedule of tank availability.
- Refer to paragraph 1.5 above

## **10.0 DOCUMENT #9 – TIRM UPDATE REPORT**

### **10.1 Purpose**

The results of the above initiatives will be incorporated into an update to the TIRM Report.

### **10.2 Outline**

1. Data Entry and Documentation (5.7)
  - Refine process to eliminate entry errors (5.7.1)
  - Eliminate intermediate steps in data handling (5.7.2)
  - Screening for outlier data (5.7.3)
2. Auditing of Quality Control Program (5.8)
  - Spot checks (metal loss) using Contractor NDE (5.8.1)
  - Spot checks (metal loss) using 3rd party NDE (5.8.2)
  - Spot checks (metal loss) using destructive means (5.8.3)
  - Spot checks of Quality Control documentation (5.8.4)
  - Negative Performance Incentives (rework, removal of personnel, rejection of work) (5.8.5)
  - Acceptance sampling plan (Develop after “Inspection Data, LFET, and Step 2 Analysis Report”) (5.8.6)
3. Changes to Quality Assurance Procedures (6.3)
4. Tank Inspection Specification (6.2)
  - Specs, drawings, etc. (6.2.1)
  - Qualification of Inspectors (6.2.2)
  - Testing procedures (6.2.3)
  - Reporting procedures (6.2.4)
  - Audit coupons (6.2.5)
5. Tank Repair Specification (6.2)
  - Specs, drawings, etc. (6.2.1)
  - Qualification of Inspectors (6.2.2)
  - Testing procedures (6.2.3)
  - Reporting procedures (6.2.4)
  - Audit coupons (6.2.5)
6. Removal of telltales (4.8)

### **10.3 Schedule**

- May 2022- Dependent on other studies and testing
- Refer to paragraph 1.5 above



## **11.0 DOCUMENT #10 - OVERALL CORROSION ASSESSMENT REPORT (OCA) (6.1)**

### **11.1 Purpose**

The Overall Corrosion Assessment Report will amalgamate the Preliminary Concrete Assessment Report (Document #3) and the Preliminary Liner Corrosion Assessment Report (PLCA) (Document #2) into a unified synopsis of corrosion in the Red Hill storage tanks. (6.1)

### **11.2 Outline**

1. Report on results

### **11.3 Schedule**

- March 2022
- Dependent on other studies and testing
- Refer to paragraph 1.5 above

This Page is Intentionally Left Blank

**APPENDIX A - AOC Section 5.4 Scope of Work Outline (1 September 2020)**

This Page is Intentionally Left Blank

## AOC SECTION 5.4 SCOPE OF WORK OUTLINE (1 September 2020)

### 1. Interpretation of the Coupon Results

PURPOSE: The RAs interpretation of the Destructive Testing Report was that there were two (2) False Positives and two (2) False Negatives. The Navy/DLA will address the following topics in response to the RAs interpretation.

[REDACTED]

### 2. Deficiencies in Data Collected

PURPOSE: The RAs stated that Navy's laboratory analysis did not or was unable to identify the thinnest portion of each plate which made the destructive testing exercise and its analysis incomplete. The Navy/DLA will address the following topics in response to the RAs statement.

[REDACTED]

### 3. Uncertainty Regarding NDE Accuracy

PURPOSE: The RAs stated there is insufficient correlation between NDE and the laboratory measurements. The Navy/DLA will address the following topics in response to the RAs statement.

[REDACTED]

### 4. Potential for Increased Rates of Corrosion

PURPOSE: The RAs stated a belief the Navy is underestimating corrosion rates for Tank 14 and should reassess corrosion rates used in calculating minimum remaining thickness under TIRM. Also, it was stated the potential cause for increasing corrosion rates creates concern for potential corrosion of embedded reinforcement in the concrete. The Navy/DLA will address the following topics in response to the RAs statement.

#### 4.1. Method by which Corrosion Rate is calculated

4.1.1. Evaluate potential causes for corrosion and possible actions to reduce corrosion rates, if possible.

#### 4.2. Using extreme value vs uniform to establish Minimum Remaining Thickness

#### 4.3. [REDACTED] theory concerning metal liner

#### 4.4. Environmental and chemical conditions affecting rates

- 4.5. [REDACTED] theory concerning reinforced concrete
- 4.6. Potential causes for corrosion
- 4.7. Rainfall effects on metal liner
- 4.8. Removal of telltales
- 4.9. Potential corrosion impact from use of old versus new carbon steel Patch Plates
  - 4.9.1. Potential Galvanic corrosion between new patch plate and old carbon steel liner
  - 4.9.2. Potential for weld stress due to crevice corrosion in the gap between the steel liner and a new patch plate

5. Recommendations for Moving Forward

PURPOSE: The following topics were developed during discussions with the RAs during previous Scoping meetings from 4 June 2020 to 11 August 2020. These topics will be addressed, analyzed, and discussed thoroughly by Navy/DLA. The Navy/DLA will provide this information and documentation to the RAs as they are developed.

[REDACTED]

- 5.2. Factor of Safety
  - 5.2.1. Comparison with other Industries (API, ASME, ASCE, etc.)
- 5.3. Corrosion Rates
  - 5.3.1. Address extreme value (e.g., timber lodged behind plate) vs uniform rate
  - 5.3.2. Comparison to API 650 tank steel bottom
  - 5.3.3. Reevaluate the repair threshold and associated factor of safety to account for inaccuracies in NDE, corrosion rates, and possible delays in repair cycles.
- [REDACTED]
- 5.3.5. Laboratory study to attempt to distinguish between recent and historic corrosion
- 5.4. Conduct additional analyses on the condition of the concrete structure and embedded reinforcing steel.
  - 5.4.1. Study existing concrete pursuant to principles of ACI 364-1R
  - 5.4.2. Cores might include embedded reinforcing steel
  - 5.4.3. Physical, chemical, and mechanical properties of the concrete will be studied

[REDACTED]

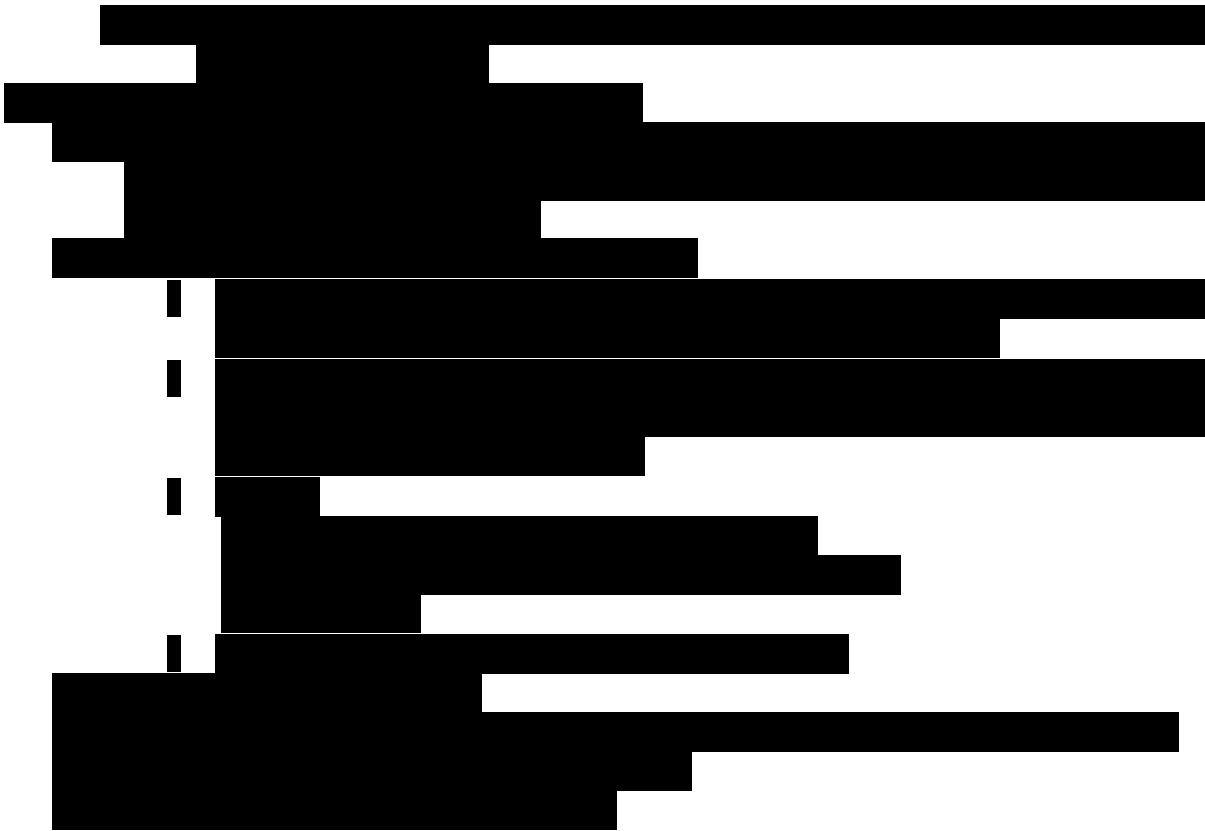

- 5.7. Data Entry and Documentation
  - 5.7.1. Refine process to eliminate entry errors
  - 5.7.2. Eliminate intermediate steps in data handling
  - 5.7.3. Screening for outlier data
- 5.8. Auditing of Quality Control Program
  - 5.8.1. Spot checks (metal loss) using KTR NDE
  - 5.8.2. Spot checks (metal loss) using 3rd party NDE
  - 5.8.3. Spot checks (metal loss) using destructive means
  - 5.8.4. Spot checks of QC documentation
  - 5.8.5. Negative Performance Incentives (rework, removal of personnel, rejection of work)
  - 5.8.6. Acceptance sampling plan

6. Validation of Initiatives

PURPOSE: The results of the above five (5) initiatives will be incorporated into the following topics:

- 6.1. Report on results
- 6.2. Implement Changes to Specifications
  - 6.2.1. Specs, drawings, etc. that they give to the contractors. Those are what we should be reviewing.
  - 6.2.2. Qualification of Inspectors
  - 6.2.3. Testing procedures
  - 6.2.4. Reporting procedures
  - 6.2.5. Audit coupons
- 6.3. Changes to Quality Assurance procedures

This Page is Intentionally Left Blank



**APPENDIX B - Schedule**

This Page is Intentionally Left Blank

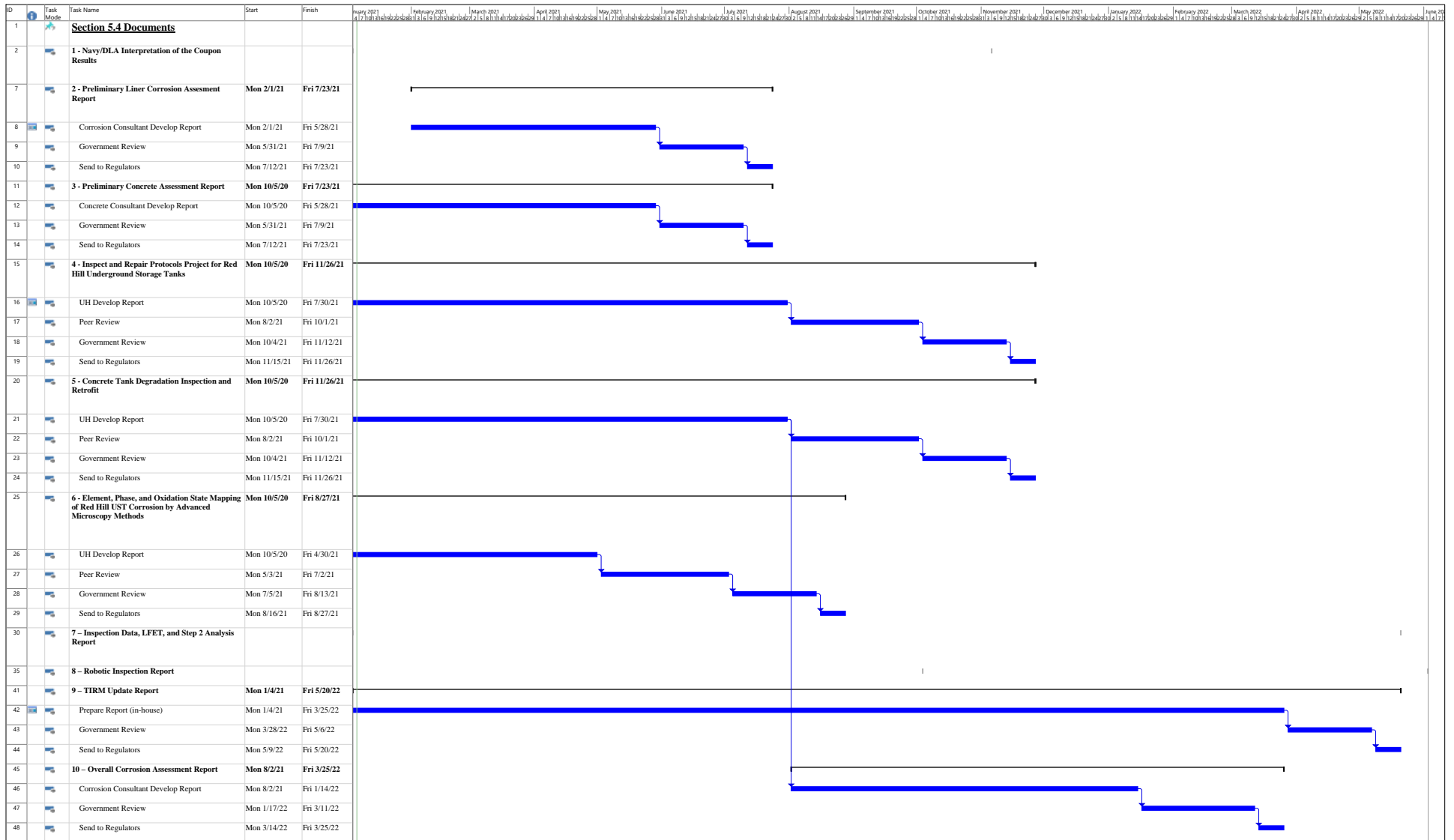

This Page is Intentionally Left Blank.

**APPENDIX C**  
**Contract Statement of Work – Provide Red Hill Corrosion Assessment**

This Page is Intentionally Left Blank.



**CONTRACT STATEMENT OF WORK**

**Project Title:** Provide Red Hill Corrosion Assessment  
**Contract No:** N39430-19-D-2170  
**Task Order:** TBD  
**WON:** 1674309  
**Contractor:** Solomon Resources, LLC.  
**ACQR:** 5810655

**SOW HISTORY**

<b>Version</b>	<b>Date</b>	<b>Description</b>
Basic Award	01 Jul 2020	Original Scope

**Date:** 01 Jul 2020  
**Submitted By:** Frank Kern

Contents

1 NEED ..... 1

1.1 Background ..... 1

1.2 Goals and Objectives ..... 1

2 REQUIREMENTS ..... 1

2.1 Corrosion Subject Matter Expert ..... 1

2.2 Task 1 Preliminary Liner Corrosion Assessment..... 2

**2.2.1** Preliminary Nature of Assessment..... 2

**2.2.2** Literature Review ..... 2

**2.2.3** Analysis of Inspection Records..... 2

**2.2.4** Preliminary Liner Corrosion Assessment Report ..... 2

**2.2.5** Electronic Meetings and Phone Calls ..... 3

2.3 Task 2 SME Consultant Work ..... 3

**2.3.1** External Report Analysis ..... 3

**2.3.2** Third Party Review Response..... 3

**2.3.3** Appearance and Participation at Public and Regulatory Agency Meetings..... 4

**2.3.4** Mobilizations ..... 4

2.4 Task 3 Overall Corrosion Assessment ..... 4

**2.4.1** Overall Corrosion Assessment Report..... 5

**2.4.2** Prefinal OCA ..... 5

**2.4.3** Final OCA..... 5

2.5 Schedule ..... 5

2.6 References..... 5

3 GENERAL REQUIREMENTS ..... 5

3.1 Work Hours..... 5

3.2 No Waiver by the Government ..... 5

3.3 Information Security ..... 6

3.4 Proprietary Rights ..... 6

3.5 Installation Access ..... 6

3.6 Safety and Occupational Health Requirements..... 6

**3.6.1** Accident Notification and Reports..... 7

4 CONTRACT MEETINGS AND REPORTING ..... 7

4.1 Kickoff Meeting / Teleconference ..... 7

4.2 Progress Meeting/Telcon ..... 7

5 PROPOSAL ..... 7

5.1 Cost ..... 7



5.2	Technical.....	8
6	OPTION ITEMS .....	8
6.1	Option 1 - External Report Review and Analysis.....	8
6.2	Option 2 - Third Party Review Response .....	8
6.3	Option 3 - Electronic Meeting Participation .....	8
6.4	Option 4 - SME Consultant Mobilizations.....	9
7	GOVERNMENT FURNISHED INFORMATION (GFI).....	9
8	PLACE OF PERFORMANCE.....	9
9	PERIOD OF PERFORMANCE.....	9
10	PRIMARY POINTS OF CONTACT.....	9
11	GLOSSARY.....	11
	Table S Submittal List, Schedule, and Distribution.....	12

## 1 NEED

Technology to screen the steel tank liners at the Red Hill Bulk Fuel Storage Facility (RHBFSF) for backside corrosion has been used at the Facility since circa 2006. Condition reports have been produced as part of individual tank inspection and repair evolutions. A facility-wide effort to consolidate tank corrosion and condition information into a facility-wide report has not been undertaken.

### 1.1 Background

During construction of the RHBFSF, twenty mined vertical cavities were lined with butt-welded carbon steel. The liners were used as forms when reinforced concrete with thickness ranging from 2 to 5 feet was placed. At the conclusion of construction, each tank was leak-tested with water and repairs were made based on the test results. Further information is available in GFI Attachment 5 Brief Background Red Hill Tank Construction.

The liners were coated with a thin film urethane epoxy between 1960-1970. Empirical data suggest the epoxy coating has been effective at preventing product-side corrosion.

During routine inspection and electromagnetic corrosion screening done on some tanks since 2006, areas of backside corrosion have been found and repaired. The standard for repair is a modified API Std 653 approach.

During tank filling at the conclusion of a routine repair evolution in 2014, a release took place. The subsequent investigation determined the underlying cause of the release was poor workmanship and unrepaired gas test holes installed by the repair contractor. As a result of the release, Navy entered into an administrative order with Regulatory Agencies (RA). Work products of this Statement of Work will be used in concert with others to further Navy efforts to satisfy requirements of the administrative order.

### 1.2 Goals and Objectives

The goals of this project are to receive preliminary reports that will better inform Navy and DLA. The primary objective is to review corrosion data and produce a preliminary report addressing steel liner corrosion. Secondary objectives are to provide Subject Matter Expert (SME) Consultant services in the form of review and analysis of expert documents, participation in stakeholder and public meetings, testimony before regulatory agencies regarding the assessment, and briefing Navy and DLA leadership. The tertiary objective is to produce an overall corrosion assessment report.

## 2 REQUIREMENTS

In order to meet project goals, this SOW contains requirements to review reports by others, analyze data with a consultant SME, produce a preliminary liner corrosion assessment report, and produce an overall corrosion assessment report. The source data and reports, analysis, and report are non-disclosable. Individuals involved will be required to sign a statement of non-disclosure.

Provide means and methods to execute this SOW. Provide appropriate subcontractor support from qualified companies, consultant(s), and specialists to execute this SOW. Provide and distribute submittals in accordance with Table S.

### 2.1 Corrosion Subject Matter Expert

Provide the services of a corrosion subject matter expert (SME) consultant qualified by education and experience to perform expert services of storage tank corrosion assessment. Minimum education is a doctorate in engineering or closely related field. Relevant experience in corrosion assessment and evaluation of large concrete structures is required. Submit SME Consultant resume for Govt approval.

Contractor and subcontractor employee(s) shall conduct themselves in a proper, efficient, courteous, and businesslike manner. Coordination and cooperation with others is a key element to success, and is required. The Contracting Officer may require the contractor remove from the work any individual the Govt reasonably determines is uncooperative, unqualified, fails to satisfactorily perform work, is careless, objectionable, contrary to public interest, or acts inconsistent with the best interests of National Security.

## **2.2 Task 1 Preliminary Liner Corrosion Assessment**

All notes, data, comments, recommendations, specifications, and other documents collected and produced as part of this contract are property of the Govt. These data or images shall not be used, in whole or part, published or unpublished, in any technical or non-technical presentation, or otherwise released by the contractor without prior written approval of the Contracting Officer.

### **2.2.1 Preliminary Nature of Assessment**

Metal thickness data are not available for each storage tank liner at Red Hill. In addition, some reports contain sparse data. For those reasons the assessment will be produced as preliminary and subject to change should further data become available.

### **2.2.2 Literature Review**

Perform a review of literature relevant to carbon steel plates in intimate or close contact with concrete substrate. Consider (Petti, et al. 2011) and (Tuutti, 1982). Assess methods of corrosion rate determination in industry standards API 570 and 653. Review relevant Red Hill construction records which document tank design and construction. Assume electronic review of thirty vintage, hand-drafted Arch D as-built drawings.

### **2.2.3 Analysis of Inspection Records**

Provide SME consultant analysis of the corrosion data per individual tank and as part of the entire facility. Perform data manipulation as-needed to inform the analysis. Review thickness data and analysis performed by the tank inspectors. Propose a meaningful basis for establishing and reporting rates, if different from current practice. Segregate data and analysis into categories of product-side and backside corrosion. Assume quantitative data are available for analysis in six reports, each containing approximately 25-relevant pages and a large spreadsheet. Assume qualitative data are available in four reports, each containing approximately 50-relevant pages.

### **2.2.4 Preliminary Liner Corrosion Assessment Report**

Produce a preliminary liner corrosion assessment (PLCA) report. Overall objectives of the preliminary report are below.

- a. Compare and contrast the science of storage tank bottom corrosion versus the methods of corrosion rate assessment in API Standards 653 and 570
- b. Summarize the literature and science of corrosion of steel plates in contact with concrete, as it relates to conditions at Red Hill
- c. Discuss estimates of liner corrosion rates
- d. Recommendations to change in practice of corrosion rate determination

Provide a preliminary report which meets objectives, and contains commentary and analysis. Provide the PLCA Report at three levels of completion.

**2.2.4.1 Draft PLCA**

The Draft Report is an outline format containing placeholders for all elements of analyses. Populate the draft report with completed results. Analysis that is still in-progress might not be included in the draft. The Draft Report is progress-type with a level of completion expected to be 75%

**2.2.4.2 Prefinal PLCA**

The Prefinal Report contains all analysis and incorporates Govt and Subject Matter Expert (SME) comments.

**2.2.4.3 Final PLCA**

The level of completion of the Final Report is ready for publication and incorporates Govt and SME comments.

**2.2.5 Electronic Meetings and Phone Calls**

Provide SME consultant attendance and participation in technical, quality, and status meetings with the GTT. Meetings will be conducted only on an as-needed basis. Assume periodicity ranges from once every two weeks to once per month. Duration is not expected to exceed 1 hour each. Assume electronic means are commercial web conferencing (Zoom, Google, Skype, Microsoft) without video capability.

**2.3 Task 2 SME Consultant Work**

**2.3.1 External Report Analysis**

It is expected external experts will produce documents and reports pertaining to RHBFSF corrosion. Provide peer review and critical analysis of the reports. The initial audience for the review and analysis is the GTT. However, expect discussion of external documents and reports to be a topic during electronic or onsite meetings with external stakeholders. Quantity of external document and report reviews is given in Table 2.1. Assume each report or document requires 6 hours for review and analysis.

**Table 2.1 External Report Review**

Type	Quantity (ea)
Corrosion or Practices Report	5

**2.3.2 Third Party Review Response**

Review and commentary on the PLCA will take place by external third parties and RA. Expect rounds of reviews to take place at any level of completion. Some review comments might not require a report revision and will only require a response to comments. In response to the third party and RA review comments, provide SME Consultant analysis and report deliverables per Table 2.2. Assume each effort requires 4 hours of time.

**Table 2.2 Third Party Review Responses**

Work Item	Quantity (ea)
Analysis	6

Review and Respond to Comments	5
Report Supplement	2

**2.3.3 Appearance and Participation at Public and Regulatory Agency Meetings**

Provide SME consultant participation in onsite and electronic public, Govt, and RA meetings. Assume electronic meetings are telephonic or commercial web conferencing (Zoom, Google, Skype, Microsoft). Using these means, video conferencing may take place with voice supplemented with pdf screen presentation as backup. See paragraph Mobilizations for onsite meeting requirements.

Meetings with RA will involve interaction, commentary, and criticism from forensic and specialty consultants representing their respective clients. Sworn testimony to the RA in support of the preliminary corrosion assessment report is expected. Meetings with public will involve direct interaction with individuals and organizations representing the complete range of technical knowledge and experience.

Provide SME Consultant electronic meeting participation per Table 2.3. See paragraph Work Hours for time of day requirements.

**Table 2.3 Electronic Meeting Participation Schedule**

Type of Involvement	Quantity of Meetings	Hours (per meeting)
Participation, Govt Only	6	2
Participation, Govt + RA + Public	2	6

**2.3.4 Mobilizations**

Provide SME consultant mobilizations to support the corrosion assessment as well as participate in onsite Govt, RA, and public meetings. Assume onsite meetings take place in Honolulu. Assume each mobilization requires five days (two travel days, three work days). Quantity and purpose of mobilizations is per the Table 2.4.

**Table 2.4 Mobilization Schedule**

Type of Participation	Quantity (ea)
Onsite Govt Meeting	1
Onsite RA Meeting	1

**2.4 Task 3 Overall Corrosion Assessment**

Preparation of a preliminary concrete assessment report (concrete report) is underway by others. The report will assess the quality and durability of RHBFSF reinforced concrete. Provide SME services to review the concrete report and be familiar with its principal findings. Formulate an Overall Corrosion Assessment (OCA) which amalgamates the concrete report and the PLCA into a unified synopsis of corrosion in the Red Hill storage tanks.

Assume the concrete report contents will not be available for inclusion until June 2021. The COR will advise of more specific delivery information once available. Assume relevant portions of the concrete report do not exceed 100-pages.

#### **2.4.1 Overall Corrosion Assessment Report**

Produce an OCA report based on the PLCA and the concrete report. Contents of the report are principal findings, conclusions, and opinions contained in both the concrete report and the PLCA report. The audience for the OCA report is Navy and DLA leadership and the general public.

Utilize the services of a technical writer to tailor the report to the audience. Make use of illustrative graphics and professional editing to ensure fundamental concepts are easily understood by non-technical individuals.

#### **2.4.2 Prefinal OCA**

The Prefinal OCA Report contains all analysis, graphics, and information. Produce the Prefinal Report no later than 90-days after receipt of information from the concrete assessment report.

#### **2.4.3 Final OCA**

The level of completion of the Final OCA Report is ready for publication and incorporates Govt comments.

### **2.5 Schedule**

Within three weeks of award, provide a schedule which details performance of all work in this SOW. Use placeholder dates for the mobilizations. Build time into the schedule to receive the concrete report and perform Task 3 activities.

### **2.6 References**

Petti, Jason P, Dan Naus, Richard E Weyers, Bryan A Erler, Neal S Berke, and Alberto Sagüés. 2011. *Nuclear Containment Steel Liner Corrosion Workshop: Final Summary and Recommendations Report*. Technical Report, Albuquerque: Sandia National Laboratories.

Tuutti, K. 1982. *Corrosion of Steel in Concrete*. Research Thesis, Stockholm: Swedish Cement and Concrete Research Institute.

## **3 GENERAL REQUIREMENTS**

Comply with all federal, state, and local regulations. The term construction refers to any construction-type support activity which is required to execute this Statement of Work.

Coordinate planned work activities with the GTT. Report exceptions and deviations from this Statement of Work to the Contracting Officer. Only the Contracting Officer has the authority to authorize work or de-scope work elements of this Task Order.

### **3.1 Work Hours**

Unless otherwise notified, SME Consultant meetings with Govt and RA will take place during normal business hours, Hawaii Standard Time. Meetings with the public are expected to take place between the hours of 1200 HST – 2100 HST.

### **3.2 No Waiver by the Government**

The failure of the Govt in any one or more instances to insist upon strict performance to any of the terms of this contract or to exercise any option herein conferred shall not be construed as a waiver or

relinquishment to any extent of the right to assert or rely upon such terms or options on any future occasion.

### **3.3 Information Security**

Security requirements apply to all contractors, subcontractors, and suppliers associated with this contract. In addition to special or extraordinary security requirements, comply with the following:

- a. Do not publicly disclose information concerning any aspect of the design or services relating to this contract, without prior written approval of the Contracting Officer.
- b. Do not disclose or cause to be disseminated information concerning the operations of the activity, operations of the activity's security, or information regarding the continuity of operations.
- c. Do not disclose any information to any person not entitled to receive it. Failure to safeguard any classified information that may come to the Contractor or any person under his control, may subject the Contractor, his agents or employees to criminal liability under 18 U.S.C., Sections 793 and 798.
- d. Direct to the Contracting Officer or Installation Security Officer for resolution all inquiries, comments or complaints arising from any matter observed, experienced, or learned as a result of or in connection with the performance of this contract, the resolution of which may require the dissemination of official information.
- e. Coordinate photography with Installation requirements. Photo permit requests are processed by the Joint Base.
- f. This effort will result in an aggregation of information which is sensitive and is protected from disclosure. A non-disclosure agreement will be required. Certain documents must be labeled privileged from disclosure.

Deviations from or violations of any of the provisions of this section, will, in addition to all other criminal and civil remedies provided by law, subject the Contractor to immediate termination for default and withdrawal of the Govt acceptance and approval of employment of the individuals involved.

### **3.4 Proprietary Rights**

All field notes, drawings, photographs, specimens, specifications, findings, data, and documents collected and produced as part of this contract become property of the Govt. These data shall not be used, in whole or part, published or unpublished, as a part of any technical or non-technical presentation, or otherwise released by the Contractor without written approval of the Contracting Officer.

### **3.5 Installation Access**

Submit request for access in accordance with DBIDS for JBPHH. Fulfill required background and fingerprint investigation information requests within one week of initiation. For workers already in possession of DBIDS access or a CAC, coordinate access requirements with the COR. For single-day access into Red Hill, it is not expected that all steps on the FLCPH badging flow chart will be required. Coordinate access requirements with the COR.

### **3.6 Safety and Occupational Health Requirements**

Submit an abbreviated APP compliant with USACE EM 385-1-1 Appendix A. Submit matters of interpretation of standards to the COR for resolution before starting work. Where the requirements of this SOW, applicable laws, criteria, ordinances, regulations, and referenced documents vary, the most stringent requirements shall apply.

**3.6.1 Accident Notification and Reports**

For recordable injuries and illnesses, and property damage accidents resulting in at least \$2,000 in damages, contractor shall:

- a. Provide initial notification via telephone or email as soon as possible from the time of mishap.
- b. Provide initial contractor Incident Reporting System (CIRS) report within 4-hours of mishap.
- c. Conduct an accident investigation to establish the root cause(s) of the mishap.
- d. Provide final CIRS report within five calendar days of mishap.
- e. COR will provide forms or electronic system access for CIRS report.

Notify the Contracting Officer as soon as practical, but not later than four hours, after any accident meeting the definition of Recordable Injuries or Illnesses or High Visibility Accidents, property damage equal to or greater than \$2,000, or any weight handling equipment accident. Include contractor name; contract title; type of contract; name of activity, installation or location where accident occurred; date and time of accident; names of personnel injured; extent of property damage, if any; extent of injury, if known, and brief description of accident (e.g., type of equipment being used, PPE used). Preserve the conditions and evidence on accident site until the Govt investigation team arrives and Govt investigation is conducted.

**4 CONTRACT MEETINGS AND REPORTING**

**4.1 Kickoff Meeting / Teleconference**

Upon Task Order award, within three weeks host a telephonic Kickoff Meeting with the GTT to establish the responsibilities of parties, to discuss the schedule, and to ensure mutual understanding of the scope. Prepare the meeting agenda. After opening remarks by the COR, lead the discussion of specific project requirements. Generate and submit meeting minutes for COR review and approval. This meeting shall occur prior to contractor personnel starting work.

**4.2 Progress Meeting/Telcon**

At various times, coordinate and host progress meetings with the GTT. The intent will be to discuss progress, quality, coordination, and mutual understanding. Meetings dates will be determined later. Assume they are telephonic. The COR will notify contractor when meetings are required. Prepare and submit brief minutes of the meetings per Table S.

**5 PROPOSAL**

**5.1 Cost**

Provide a detailed cost proposal for Tasks identified in Table 5.1 required to execute work in this SOW.

**Table 5.1 Cost Proposal**

Task 1 Preliminary Liner Corrosion Assessment	\$
Task 2, SME Consultant Work	\$
Task 3 Overall Corrosion Assessment (OCA)	\$



Administrative Submittals	\$
---------------------------	----

**5.2 Technical**

Provide proposal with succinct detail that demonstrates understanding and compliance with the principal means and methods. Identify proposed subcontractors. Provide a resume for the SME Consultant that demonstrates qualification and expertise.

**6 OPTION ITEMS**

In the event quantities of work are required in excess of what is in this SOW, Navy would like to establish unit prices for several Option Items. Should the work become necessary, unit prices will provide the basis for rapid execution of a change. Provide a fully burdened cost for optional work, using the referenced SOW paragraph as the basis for each Option Item, pursuant to the tables below. Option Item prices remain valid for the duration of the period of performance.

Only the Contracting Officer has the authority to authorize Option Item work. Do not proceed with any Option Item work unless the option has been exercised and the work is authorized by the Contracting Officer.

**6.1 Option 1 - External Report Review and Analysis**

Basis for the option work is paragraph External Report Analysis.

**Table 6.1 Optional External Report Review**

Type	Unit of Measure	Price
Corrosion or Practices Report	Each	\$

**6.2 Option 2 - Third Party Review Response**

Basis for the option work is paragraph Third Party Review Response.

**Table 6.2 Optional Third Party Review Responses**

Work Item	Unit of Measure	Price
Analysis	Each	\$
Review and Respond to Comments	Each	\$
Report Supplement	Each	\$

**6.3 Option 3 - Electronic Meeting Participation**

Basis for the option work is paragraph Appearance and Participation at Public and Regulatory Agency Meetings.

**Table 6.3 Optional Electronic Meeting Participation**

Type of Involvement	Unit of Measure	Price
Participation, Govt + RA + Public	Each Meeting	\$

**6.4 Option 4 - SME Consultant Mobilizations**

Basis for the optional work is paragraph Mobilizations.

**Table 6.4 Optional Mobilization**

Type of Participation	Unit of Measure	Price
Onsite Meeting	Each	\$

**7 GOVERNMENT FURNISHED INFORMATION (GFI)**

1. DBIDS for JBPHH
2. SECNAV 5512-1
3. FLCPH Badging Flow Charts
4. JB2 0-180
5. Brief Background Red Hill Tank Construction

**8 PLACE OF PERFORMANCE**

Joint Base Pearl Harbor Hickam, Honolulu, Hawaii.

**9 PERIOD OF PERFORMANCE**

The anticipated period of performance is 16 months from date of award.

**10 PRIMARY POINTS OF CONTACT**

Contracting Officer

Mr. Sal Vargas  
NAVFAC EXWC Code ACQ72  
1100 23rd Avenue, Building 1100, Port Hueneme, CA 93043-4347  
(805) 982- 2565  
salvador.r.vargas1@navy.mil

Government Technical Team

Project Manager  
Ms. Terri Regin  
NAVFAC EXWC Code CI112  
720 Kennon Street, S.E. Suite 333  
Washington Navy Yard, DC 20374  
DSN: 288-5196  
Phone: (202) 433-5196

terri.regin@navy.mil

Project Engineer

Mr. Patrick Hauk  
NAVFAC EXWC Code CI112  
1000 23<sup>rd</sup> Avenue  
Port Hueneme, CA 93043 DSN: 288-5196  
(805) 982- 1187  
patrick.hauk@navy.mil

Design Manager, COR

Mr. Frank Kern  
NAVFAC EXWC Code CI112  
1000 23<sup>rd</sup> Avenue  
Port Hueneme, CA 93043  
(805) 982- 2149  
frank.kern@navy.mil

## 11 GLOSSARY

ACI	American Concrete Institute	EXWC	Engineering and Expeditionary Warfare Center
API	American Petroleum Institute	FLCPH	Fleet Logistics Center Pearl Harbor
ASCE	American Society of Civil Engineers	GTT	Government Technical Team
ASTM	American Society for Testing and Materials	Govt	Government
CAC	Common Access Card	GFI	Government Furnished Information
CD	Compact Disc	JBPHH	Joint Base Pearl Harbor Hickam
COR	Contracting Officer's Representative	KTR	Contractor
DBIDS	Defense Biometric Identification System	NAVFAC	Naval Facilities Engineering Command
DoD	Department of Defense	SEM	Scanning Electron Microscope
DLA	Defense Logistics Agency	SOW	Statement of Work
EDS	Energy-Dispersive X-ray Spectroscopy	USACE	US Army Corps of Engineers

**END STATEMENT OF WORK**

**Table S Submittal List, Schedule, and Distribution**

Submittal Description	Submittal Schedule			Distribution
	Initial	Govt. Review	Final	
Incident Reports	24 hrs after	-	-	EC
Project Schedule	3 WACA	1 week	-	EC
SME Consultant Resume	3 WACA	1 Week	-	EC
Safety Plan	3 WACA	2 weeks	1 WAGR	EC
Meeting Minutes	2 BD after	-	-	EC
Preliminary Liner Corrosion Assessment (PLCA) Report	1 WACO	1 Week	1 WAGR	EC
Overall Corrosion Assessment (OCA) Report	1 WACO	2 Week	2 WAGR	EC
External Report Review	1 WACO	1 Week	-	EC
Third Party Review Response	1 WACO	1 Week	-	EC

Legend / Notes:

WACA – Weeks after Contract Award

WACO – Weeks after Completion of Applicable Work

WAGR – Weeks after Govt Review

BD – Business Days

EC – Electronic Copy, subject to format / e-mail size requirements specified in the SOW

HC – Hard Copies, quantity four (4). Each hard copy shall include a CD/DVD insert including electronic copies of the report. contractor shall provide another eight (8) electronic copies of the report on CD/DVD

[1] – Weekly reports shall be e-mailed by 1000 local time of the first following business day

This Page is Intentionally Left Blank.

**APPENDIX D**  
**Contract Statement of Work – Access Reinforced Concrete Red Hill**

This Page is Intentionally Left Blank.





**CONTRACT STATEMENT OF WORK**

**Project Title:** Assess Reinforced Concrete Red Hill  
**Contract No:** N39430-19-D-2170  
**Task Order:** N3943020F4219  
**WON:** 1675241  
**Contractor:** Solomon Resources, LLC.  
**ACQR:** TBD

**SOW HISTORY**

<b>Version</b>	<b>Date</b>	<b>Description</b>
Basic Award	23 Sep 2020	Original Scope
Mod	26 Oct 2020	Add efflorescence tests on 6 samples; ASTM C496 Tensile strength tests, Paragraph 2.2.4

**Date:** 09 Jul 2020  
**Submitted By:** Frank Kern

Contents

- 1 NEED ..... 1
  - 1.1 Background ..... 1
  - 1.2 Goals and Objectives ..... 1
    - 1.2.1 Assessment Plan Overview ..... 1
- 2 REQUIREMENTS ..... 2
  - 2.1 Task 1 Concrete Sample Acquisition ..... 2
    - 2.1.1 Concrete Cores ..... 2
    - 2.1.2 Documentation ..... 2
    - 2.1.3 Repair of Concrete ..... 2
    - 2.1.4 Core Handling, Preparation, and Shipping ..... 2
  - 2.2 Task 2 Laboratory Testing, Examination, and Reports ..... 3
    - 2.2.1 Laboratory Accreditation ..... 3
    - 2.2.2 Efflorescence Samples ..... 3
    - 2.2.3 Phased Laboratory Examination ..... 3
    - 2.2.4 Physical Properties ..... 3
    - 2.2.5 Chemical Properties ..... 4
    - 2.2.6 Petrographic Examination ..... 4
    - 2.2.7 Laboratory Report ..... 4
  - 2.3 Task 3 SME Consultant Work ..... 4
    - 2.3.1 Laboratory Report Analysis ..... 4
    - 2.3.2 External SME Report Analysis ..... 5
    - 2.3.3 Preliminary Nature of Assessment ..... 5
    - 2.3.4 Preliminary Concrete Assessment ..... 5
    - 2.3.5 Preliminary Concrete Assessment Report ..... 5
    - 2.3.6 Electronic Meetings and Phone Calls ..... 7
    - 2.3.7 Participation in Public and Regulatory Agency Meetings ..... 7
    - 2.3.8 Mobilizations ..... 7
  - 2.4 Schedule ..... 8
  - 2.5 Informative References ..... 8
  - 2.6 Normative References ..... 8
- 3 GENERAL REQUIREMENTS ..... 9
  - 3.1 Work Hours ..... 9
  - 3.2 No Waiver by the Government ..... 10
  - 3.3 Information Security ..... 10
  - 3.4 Proprietary Rights ..... 10

3.5	Installation Access and Red Hill Badging .....	10
3.6	Safety and Occupational Health Requirements.....	11
<b>3.6.1</b>	Accident Notification and Reports.....	11
4	CONTRACT MEETINGS AND REPORTING .....	11
4.1	Kickoff Meeting / Teleconference .....	11
4.2	Concrete Core Preparatory Phase Meeting .....	11
4.3	Progress Meeting/Telcon .....	11
5	PROPOSAL .....	12
5.1	Cost .....	12
5.2	Technical.....	12
6	OPTION ITEMS .....	12
6.1	Option 1 - External Report Review and Analysis.....	12
6.2	Option 2 - Third Party Review Response .....	12
6.3	Option 3 - Electronic Meeting Participation .....	13
6.4	Option 4 - SME Consultant Mobilizations.....	13
6.5	Option 5 - Laboratory Testing .....	13
7	GOVERNMENT FURNISHED INFORMATION.....	14
8	PLACE OF PERFORMANCE.....	14
9	PERIOD OF PERFORMANCE.....	14
10	PRIMARY POINTS OF CONTACT.....	14
11	GLOSSARY.....	16
	Table S Submittal List, Schedule, and Distribution.....	17

## **1 NEED**

The Red Hill Bulk Fuel Storage Facility (RHBFSF) was constructed with unique methods. Into mined vertical cavities, welded steel tank liners and steel reinforcement were installed. Using the liners as forms, concrete batched in an onsite plant was placed. The concrete was later prestressed by pressure grouting and the entire envelope was surrounded by a massive quantity of consolidation grouting.

Empirical evidence and a preliminary assessment of the RHBFSF demonstrate the concrete is in good condition. Further information about the quality and durability of the RHBFSF concrete, and the potential for corrosion in the reinforcement is needed. The basis for this information is an analysis of mechanical, physical, and material properties. Due to characteristics of the facility and the potential for deleterious consequences of ad hoc destructive testing, a deliberate approach that will mitigate damage to the infrastructure is necessary.

### **1.1 Background**

During construction of the RHBFSF, an onsite batch plant was used to prepare the concrete as well as crush, classify, and convey aggregate. The source of the aggregate was the mining operation which produced cavities that became the adits, tunnels, and tanks. An exception to this process was Tanks 1-3 which used ready-mix concrete procured from a local supplier during construction.

A preliminary assessment of the concrete, consistent with ACI 364-1R was initiated in 2018. During that assessment, a review of pertinent design and construction documentation and relevant literature was performed, a visual examination of the condition of the concrete was conducted, an appraisal of the technical standard of care used during design and construction was made, and laboratory test results from material samples obtained by others were reviewed. Samples of powdered efflorescence were obtained from gunite surfaces for examination.

### **1.2 Goals and Objectives**

The goals of this project are to expand on the previous assessment, issue a preliminary report, and better inform Navy and DLA. The primary objective is to acquire concrete samples, test them in a laboratory, analyze results, and produce a preliminary assessment report of the reinforced concrete. Secondary objectives are to provide Subject Matter Expert (SME) Consultant services in the form of review and analysis of expert documents, participation in stakeholder and public meetings, testimony before regulatory agencies regarding the assessment, and briefing Navy and DLA leadership.

#### **1.2.1 Assessment Plan Overview**

In accordance with guidance in USACE EM 1110-2-2002, this study is intended to further the preliminary assessment already initiated with laboratory tests and analyses of specimens of the RHBFSF concrete. Pursuant to principles of ASTM C823/C823M, the current working hypothesis is the concrete is in good condition. Thus, the need for the assessment is not due to concrete deterioration or a failure to perform to expectations. Rather, the intent is to provide information to be used, consistent with principles of ACI 364-1R, to broaden the base of knowledge about the reinforced concrete and further inform the hypothesis. Information about service life will be developed considering concepts in ACI 365.1R.

In order to characterize the reinforced concrete at the Facility, the plan is to acquire data that bracket conditions both geometrically (upper and lower) and temporally (early, middle, late). These data will be compared to similar-vintage specimens. Concrete specimens will be obtained from three tanks as well from a vent structure.

Tests followed by qualitative and quantitative analyses will be performed on the specimens in the following categories.

- a. Physical Properties
- b. Chemical Properties
- c. Petrographic Properties

## **2 REQUIREMENTS**

In order to meet project goals, this Statement of Work (SOW) contains requirements to obtain samples of concrete, procure laboratory testing and petrographic examination of the samples, analyze results by a consultant SME, and produce a concrete assessment report. The test program, data, results, analysis, and report (collectively: Test) are non-disclosable. Individuals involved will be required to sign a statement of non-disclosure.

Provide means and methods to execute this SOW which includes the Task Order Specifications. Provide appropriate subcontractor support from qualified companies, consultant(s), and specialists to execute this SOW. Provide and distribute submittals in accordance with Table S and Task Order Specifications.

### **2.1 Task 1 Concrete Sample Acquisition**

Contractor and subcontractor employee(s) shall conduct themselves in a proper, efficient, courteous, and businesslike manner. Coordination and cooperation with others is a key element to success, and is required. The Contracting Officer may require the contractor remove from the work any individual the Govt reasonably determines is uncooperative, unqualified, fails to perform satisfactory work, is careless, objectionable, contrary to public interest, or acts inconsistent with the best interests of National Security.

#### **2.1.1 Concrete Cores**

Engage a qualified mechanical contractor experienced and badged for entry into RHBFSF. Remove and secure eight core samples of reinforced concrete in accordance with Section 02 25 16.00 20. Approximate size of each sample is a 6-inch diameter x 12-inch long cylinder. Obtain three samples from areas accessed by the upper tunnel, and three from areas accessed by the lower tunnel. Two cores will be obtained from an atmospheric vent structure on the exterior of the facility. Assume interior samples are horizontal, blind cores removed from below the manway plug and at the base of the product piping bulkhead in the respective cross-tunnels of Tanks 1, 5, and 19. Assume the exterior samples are horizontal, blind cores at locations accessible without scaffold. Govt will designate locations for each sample. Assume 1P 120V 15A electrical service is available within 100-feet of each interior core location, and use a portable generator on the exterior location. Assume the concrete is very hard with large, basalt aggregate. Cores are expected to cross at minimum #8 steel reinforcement.

#### **2.1.2 Documentation**

Record and provide core specimen removal information in accordance with Section 02 25 16.00 20. Use the Concrete Core Information Form included as GFI.

#### **2.1.3 Repair of Concrete**

Minimize the time between removal of a core and repair of the cavity. Protect the hole from contamination at all times. Repair the cavity in accordance with Section 02 25 16.00 20. Do not allow repair materials to be damaged or contaminated.

#### **2.1.4 Core Handling, Preparation, and Shipping**

Take and maintain custody of the core samples from time they are removed to the time they are delivered to the shipping company. Provide rugged watertight shipping cases pursuant to Section 02 25 16.00 20.

Use commercial transport with tracking and signature service to deliver the core specimens to the test laboratory. Handle, prepare, protect, pack, and ship the core specimens in accordance with Section 02 25 16.00 20. At the conclusion of testing and petrographic examinations, ship the mounted sections and the shipping cases containing fitted polyethylene foam to the Navy laboratory at the direction of the Contracting Officer Representative (COR).

## **2.2 Task 2 Laboratory Testing, Examination, and Reports**

All test notes, data, photographs, specimens, sections, results, designs, comments, recommendations, specifications, and other documents collected and produced as part of this contract are property of the Govt. These data or images shall not be used, in whole or part, published or unpublished, in any technical or non-technical presentation, or otherwise released by the contractor without prior written approval of the Contracting Officer.

Provide sample preparation, laboratory testing, and report by an accredited laboratory to accomplish goals and objectives of this SOW and in accordance with Section 02 25 16.00 20. Analyze physical and chemical properties, and perform petrographic examination on the concrete specimens in two phases. Analyze chemical properties on six samples of powdered efflorescence which will be provided by Govt. Overall objectives of the laboratory testing and examination are below.

- a. Provide the basis for SME analysis.
- b. Determination of the condition of the concrete.
- c. Determination of probable future performance of the concrete.

### **2.2.1 Laboratory Accreditation**

Use an experienced laboratory accredited, in accordance with Section 02 25 16.0 20, by ISO 17025 for test methods to be performed.

### **2.2.2 Efflorescence Samples**

Perform tests on the efflorescence samples and report their primary chemical constituents. They are expected to contain carbonates.

### **2.2.3 Phased Laboratory Examination**

In Phase 1, perform and report a visual inspection and photo documentation of each specimens. Perform an initial petrographic examination to identify differences in the concrete, determine which are suitable for strength testing and which are suitable for other testing, and inform a recommended plan for the palette and sequence of physical, chemical, and petrographic tests on the specimens. Once determinations are made, schedule a Lab Test Plan meeting with the GTT and the SME Consultant to discuss the plan.

In Phase 2, execute the plan along with preliminary petrographic analysis to determine which specimens are most suited for ASTM C457 testing. Assess the quantity of SEM examinations recommended to be conducted.

#### **2.2.3.1 Lab Test Plan Meeting**

Purpose is to achieve concurrence between the Laboratory, the SME Consultant, and the Government technical team as to which tests will be conducted and the proposed order of testing. Duration is not expected to exceed 2 hours. Electronic means are commercial voice, or web conferencing (Zoom, Google, Skype, Microsoft) without video capability.

### **2.2.4 Physical Properties**

Perform tests on the concrete specimens in accordance with Section 02 25 16.00 20. Test compressive

strength on specimens from early, middle, and late batch production categories. Test two samples and report results for splitting tensile strength (Brazilian) per ASTM C496.

#### **2.2.5 Chemical Properties**

Perform tests on the concrete specimens in accordance with Section 02 25 16.00 20. Test soluble chloride and sulfate concentration as a function of depth of concrete from the surface.

#### **2.2.6 Petrographic Examination**

Perform tests on the concrete specimens in accordance with Section 02 25 16.00 20 and ASTM C856. Prepare, mount, and polish thin sections from the surface and interior as needed to perform examination. Capture data from at least early, middle, and late batch production categories. Specific purposes of the petrographic examination are consistent with ASTM C856 Test Specimens from Actual Service, supplemented by judgement of the petrographer during Phase 1 examinations. The complexity and depth of the required petrographic study is consistent with Stage 3 Confirmatory Identification as well as elements of Stage 4 such as air-void sizes and aggregate proportions (Poole and Sims 2016).

Use phenolphthalein to determine pH as a function of depth. Verify extent of carbonation using thin sections.

Use petrographic and polarizing light microscopy in the examinations. Expect use of advanced examination techniques such as x-ray diffraction. Select samples for scanning electron microscope examination, assuming four are required. Assess for the presence of delayed ettringite.

#### **2.2.7 Laboratory Report**

Provide a report which contains results and analysis of the individual tests. Prepare a description by the petrographer of the observations and examinations made during the examinations, and interpretation of the findings insofar as they relate to goals and objectives of this SOW. Provide the laboratory report at three levels of completion.

##### **2.2.7.1 Draft**

The Draft Report is an outline format containing placeholders for all tests and analyses. Populate the draft report with completed test results. Testing that is still in-progress and the petrographic analysis might not be included in the draft. The Draft Report is progress-type with a level of completion expected to be 75%

##### **2.2.7.2 Prefinal**

The Prefinal Report contains all test results, petrographic analysis, and incorporates Govt and Subject Matter Expert (SME) comments.

##### **2.2.7.3 Final**

The level of completion of the Final Report is ready for publication and incorporates Govt and SME comments.

### **2.3 Task 3 SME Consultant Work**

Provide the services of a Professional Civil Engineer qualified by education and experience to perform expert services of concrete assessment. Minimum education is a doctorate in geology or geological engineering. Relevant experience in assessment of large civil structures, Koolau basalt, and corrosion mechanisms in reinforced concrete is required. Submit SME Consultant resume for Govt approval.

#### **2.3.1 Laboratory Report Analysis**

Review and provide comments on the laboratory report and individual tests performed on the concrete

specimens. Expect laboratory report iterations of draft, prefinal, and final.

### 2.3.2 External SME Report Analysis

It is expected external experts will produce documents and reports pertaining to RHBFSF concrete. Provide peer review and critical analysis of the reports. The initial audience for the review and analysis is the GTT. However, expect discussion of external documents and reports to be a topic during electronic or onsite meetings with external stakeholders. Quantity of external document and report reviews is given in Table 2.1. Assume each report or document requires 6 hours for review and analysis.

**Table 2.1 External Report Review**

Type	Quantity (ea)
Technical Document	3
Corrosion or Repair Practices Report	2

### 2.3.3 Preliminary Nature of Assessment

Quantitative data are not available for all the concrete at Red Hill. In addition, the mix design is not known. For those reasons the assessment will be produced as preliminary and subject to change should further data become available.

### 2.3.4 Preliminary Concrete Assessment

Use the Preliminary Assessment initiated in 2018, the Laboratory Report, the literature, Red Hill storage tank construction and inspection records, and the petrographic analysis as the basis for a Preliminary Concrete Assessment Report. Compare, contrast, and characterize the Red Hill concrete environment with typical examples in the literature such as (Petti, et al. 2011), (P. K. Mehta 1988), (Ozaki and Sugata 1988), and (Tuutti, 1982). Consider adjectival classifications of environmental aggressivity provided in (Schiessel and Bakker 1988).

Informed by basis data, provide site-specific insight into concepts of residual service life considering (Tuutti, 1980) and (Andrade, Alonso and Gonzalez 1990), as well as durability considering (Samarin 1987), (Naus and Ellingwood 1986), and (Mehta and Monteiro 2006). Interpret chloride concentration results as they relate to durability and limitations inherent to the method.

Use the comparator cores as analogues to draw distinctions or similarities in materials or condition. Develop and discuss a preliminary performance analogue.

### 2.3.5 Preliminary Concrete Assessment Report

Use the services of a technical writer if necessary to prepare and format the report to the level required for publication. Below is an overview of expected elements in the preliminary report.

- a. Identified performance issues or degradation mechanisms
- b. Specimen to comparator analogue
- c. Estimation of water to cement ratio
- d. Characterization of the environment
- e. Suitability of concrete for the environment
- f. Quality of the concrete



- g. Condition of the concrete
  - 1) Potential for ingress of corrosion inducing substances
- h. Probable future performance of the concrete
- i. Likelihood of performance impediments due to corrosion in the reinforcement

Plan three progress submittals and a record preliminary report as noted below.

**2.3.5.1 Draft**

The Draft Report is an outline format containing placeholders for all known elements. Populate the draft report with known test result information from the Laboratory Report. The level of completion of the Draft Report is expected to be 50%

**2.3.5.2 Prefinal**

The Prefinal Report contains fleshed-out analysis for all elements, complete test result information from the Laboratory Report, and incorporates Govt comments. Some conclusions and recommendations might be in draft. The level of completion of the Prefinal Report is expected to be 100%.

**2.3.5.3 Final**

The Final Report contains PreFinal contents expanded to full analysis for all elements, conclusions supported by data and graphics, and incorporates Govt comments. The level of completion of the Final Report is ready for publication and incorporates Govt comments. Final is the last Govt review.

**2.3.5.4 For Record**

The record report incorporates Govt comments and includes signed professional seal(s) and is the Preliminary Concrete Assessment Report.

**2.3.5.5 Third Party Review Response**

Review and commentary on the report will take place by external third parties and Regulatory Agencies (RA). Expect rounds of reviews to take place at any level of completion. Some review comments might not require a report revision and will only require a response to comments. In response to the third party and RA review comments, provide SME Consultant analysis and report deliverables per Table 2.2. Assume minor effort requires 4 hours, and substantial effort requires 12 hours of time.

**Table 2.2 Third Party Review Responses**

Work Item	Type	Quantity (ea)
Analysis	Minor	6
Analysis	Substantial	2
Review and Response to Comments	Minor	5
Review and Response to Comments	Substantial	2

Report Supplement	Minor	4
Report Supplement	Substantial	2

**2.3.6 Electronic Meetings and Phone Calls**

Provide SME consultant attendance and participation in technical, quality, and status meetings with the GTT. Meetings will be conducted only an as-needed basis. Assume periodicity ranges from once every two weeks to once per month. Duration is not expected to exceed 1 hour each. Assume electronic means are commercial web conferencing (Zoom, Google, Skype, Microsoft) without video capability.

**2.3.7 Participation in Public and Regulatory Agency Meetings**

Provide SME consultant participation in onsite and electronic public, Govt, and RA meetings. Assume electronic meetings are telephonic or commercial web conferencing (Zoom, Google, Skype, Microsoft). Using these means, video conferencing may take place with voice supplemented with pdf screen presentation as backup. See paragraph Mobilizations for onsite meeting requirements.

Meetings with RA will involve interaction, commentary, and criticism from forensic and specialty consultants representing their respective clients. Meetings with public will involve direct interaction with individuals and organizations representing the full range of technical knowledge and experience.

Provide SME Consultant electronic meeting participation per Table 2.3. See paragraph Work Hours for time of day requirements.

**Table 2.3 Electronic Meeting Participation Schedule**

Type of Involvement	Quantity of Meetings	Hours (per meeting)
Participation, Govt Only	6	2
Participation, Govt + RA	5	3
Participation, Govt + RA + Public	2	6
Presentation to Govt	2	3
Presentation to Govt + RA	2	3

**2.3.8 Mobilizations**

Provide SME consultant mobilizations to support the concrete assessment as well as participate in onsite Govt, RA, and public meetings. Assume onsite meetings take place in Honolulu. Assume each mobilization requires five days (two travel days, three work days). Quantity and purpose of mobilizations is per the Table 2.4.

**Table 2.4 Mobilization Schedule**

Type of Participation	Quantity (ea)
Concrete Review	1

Govt Meeting	2
RA Meeting	1
Public Meeting	1

## 2.4 Schedule

Within three weeks of award, provide a schedule which details performance of all work in this SOW. Use placeholder dates for the mobilizations. Other than the onsite concrete review, assume mobilizations take place at and after production of the Final Preliminary Concrete Assessment Report.

## 2.5 Informative References

Andrade, C, M.C. Alonso, and J.A. Gonzalez. 1990. "An Initial Effort to Use the Corroion Rate Measurements for Estimating Rebar Durability." *Corrosion Rates of Steel in Concrete*. Ann Arbor: American Society for Testing and Materials. 29-37.

Mehta, P K. 1988. "Durability of Concrete Exposed to Marine Environment - A Fresh Look." *Second International Conference on the Subject of Performance of Concrete in Marine Environment*. Detroit: American Concrete Institute. 1-29.

Mehta, P. Kumar, and Paulo J M Monteiro. 2006. *Concrete Microstructure, Properties, and Materials, 3rd Ed*. New York: McGraw-Hill.

Naus, D J, and B R Ellingwood. 1986. *Report on Aging of Nuclear Power Plant Reinforced Concrete Structures*. Technical Report, Oak Ridge: Oak Ridge National Laboratory.

Ozaki, S, and N Sugata. 1988. "Sixty-Year-Old Concrete in a Marine Environment." *Second International Conference on the Subject of Performance of Concrete in Marine Environment*. Detroit: American Concrete Institute. 587-597.

Petti, Jason P, Dan Naus, Richard E Weyers, Bryan A Erler, Neal S Berke, and Alberto Sagüés. 2011. *Nuclear Containment Steel Liner Corrosion Workshop: Final Summary and Recommendations Report*. Technical Report, Albuquerque: Sandia National Laboratories.

Poole, Alan B, and Ian Sims. 2016. *Concrete Petrography, A Handbook of Investigative Techniques*. Boca Raton: CRC Press.

Samarin, Alek. 1987. "Methodology of Modeling for Concrete Durability SP 100-62." *Concrete Durability Katherine and Bryant Mather International Conference*. Detroit: American Concrete Institute. 1205-1225.

Schiessel, Peter, and R. Bakker. 1988. *RILEM Report 60-CSC Corrosion of Steel in Concrete*. RILEM Technical Committee 60-CSC, New York: Chapman and Hall.

Tuutti, K. 1982. *Corrosion of Steel in Concrete*. Research Thesis, Stockholm: Swedish Cement and Concrete Research Institute.

Tuutti, K. 1980. "Service Life of Structures with Regard to Corrosion of Embedded Steel SP 65-13." *International Conference on Performance of Concrete in Marine Environment*. Detroit: American Concrete Institute. 223-236.

## 2.6 Normative References

ACI 207.3R (2018) *Report on Practices for Evaluation of Concrete in Existing Massive Structures for Service Conditions*

ACI 364.1R (2019) *Guide for Assessment of Concrete Structures before Rehabilitation*

ACI 365.1R (2017) *Report on Service Life Prediction*

ASTM C33/C33M (2018) *Standard Specification for Concrete Aggregates*

ASTM C39/C39M (2020) *Standard Test Method for Compressive Strength of Cylindrical Concrete Specimens*

ASTM C42/C42M (2018a) *Standard Test Method for Obtaining and Testing Drilled Cores and Sawed Beams of Concrete*

ASTM C295/C295M (2019) *Standard Guide for Petrographic Examination of Aggregates for Concrete*

ASTM C387/C387M (2017) *Standard Specification for Packaged, Dry, Combined Materials for Concrete and High Strength Mortar*

ASTM C457/C457M (2016) *Standard Test Method for Microscopical Determination of Parameters of the Air-Void System in Hardened Concrete*

ASTM C469/C469M (2014) *Static Modulus of Elasticity and Poisson's Ratio of Concrete in Compression*

ASTM C642 (2013) *Density, Absorption, and Voids in Hardened Concrete*

ASTM C823/C823M (2012, R2017) *Standard Practice for Examination and Sampling of Hardened Concrete in Constructions*

ASTM C856/C856M (2020) *Standard Practice for Petrographic Examination of Hardened Concrete*

ASTM C1218/C1218M (2017) *Standard Test Method for Water-Soluble Chloride in Mortar and Concrete*

ASTM C1723 (2016) *Standard Guide for Examination of Hardened Concrete Using Scanning Electron Microscopy*

ASTM D4327 (2017) *Standard Test Method for Anions in Water by Suppressed Ion Chromatography*

USACE ER 1110-2-2002 (1995) *Evaluation and Repair of Concrete Structures*

### **3 GENERAL REQUIREMENTS**

Comply with Task Order Specifications, all federal, state, and local regulations. As used in the Task Order Specifications, the term construction refers to any construction-type support activity which is required to execute this Statement of Work.

Coordinate planned work activities with the Government Technical Team (GTT). Report exceptions and deviations from this Statement of Work to the Contracting Officer. Only the Contracting Officer has the authority to authorize work or de-scope work elements of this Task Order.

#### **3.1 Work Hours**

Unless otherwise indicated, onsite concrete assessment work will be located on a Govt compound, military installation, or station. Work hours are normally eight-hour days between 0700 and 1700 Monday through Friday. Obtain advance approval from the Contracting Officer for contractor personnel to remain on site beyond normal working hours. Notify the Contracting Officer at least 48-hours in advance to obtain approval for access to the jobsite or work outside of normal working hours or on Saturday, Sunday, and Federal Holidays.

Unless otherwise notified, SME Consultant meetings with Govt and RA will take place during normal business hours, Hawaii Standard Time. Meetings with the public are expected to take place between the hours of 1200 HST – 2100 HST.

### **3.2 No Waiver by the Government**

The failure of the Govt in any one or more instances to insist upon strict performance to any of the terms of this contract or to exercise any option herein conferred shall not be construed as a waiver or relinquishment to any extent of the right to assert or rely upon such terms or options on any future occasion.

### **3.3 Information Security**

Security requirements apply to all contractors, subcontractors, and suppliers associated with this contract. In addition to special or extraordinary security requirements, comply with the following:

- a. Do not publicly disclose information concerning any aspect of the condition reports or services relating to this contract, without prior written approval of the Contracting Officer.
- b. Do not disclose or cause to be disseminated information concerning the operations of the activity, operations of the activity's security, or information regarding the continuity of operations.
- c. Do not disclose any information to any person not entitled to receive it. Failure to safeguard any classified information that may come to the Contractor or any person under his control, may subject the Contractor, his agents or employees to criminal liability under 18 U.S.C., Sections 793 and 798.
- d. Direct to the Contracting Officer or Installation Security Officer for resolution all inquiries, comments or complaints arising from any matter observed, experienced, or learned as a result of or in connection with the performance of this contract, the resolution of which may require the dissemination of official information.
- e. Coordinate photography with Installation requirements.
- f. This effort will result in an aggregation of information which is sensitive and is protected from disclosure. A non-disclosure agreement will be required. Certain documents must be labeled privileged from disclosure.

Deviations from or violations of any of the provisions of this section, will, in addition to all other criminal and civil remedies provided by law, subject the Contractor to immediate termination for default and withdrawal of the Govt acceptance and approval of employment of the individuals involved.

### **3.4 Proprietary Rights**

All field notes, drawings, photographs, specimens, reports, findings, data, and documents collected and produced as part of this contract become property of the Govt. These data shall not be used, in whole or part, published or unpublished, as a part of any technical or non-technical presentation, or otherwise released by the Contractor without written approval of the Contracting Officer.

### **3.5 Installation Access and Red Hill Badging**

Within five days after award, for workers requiring Red Hill access, submit request(s) for access and badges in accordance with Task Order Specifications, DBIDS for JBPHH, and FLCPH Badging Flowcharts. Fulfill required background investigation information requests within one week of initiation. For workers already in possession of DBIDS access, a CAC, or a Red Hill badge, coordinate access requirements with the COR.

### **3.6 Safety and Occupational Health Requirements**

Comply with USACE EM 385-1-1 and Section 01 35 26. Ensure a qualified Site Safety and Health Officer is onsite during work at Red Hill.

Submit matters of interpretation of standards to the COR for resolution before starting work. Where the requirements of this SOW, Task Order Specifications, applicable laws, criteria, ordinances, regulations, and referenced documents vary, the most stringent requirements shall apply. Govt safety oversight will be led by designated representatives.

#### **3.6.1 Accident Notification and Reports**

For recordable injuries and illnesses, and property damage accidents resulting in at least \$2,000 in damages, contractor shall:

- a. Provide initial notification via telephone or email as soon as possible from the time of mishap.
- b. Provide initial contractor Incident Reporting System (CIRS) report within 4-hours of mishap.
- c. Conduct an accident investigation to establish the root cause(s) of the mishap.
- d. Provide final CIRS report within five calendar days of mishap.
- e. COR will provide forms or electronic system access for CIRS report.

Notify the Contracting Officer as soon as practical, but not later than four hours, after any accident meeting the definition of Recordable Injuries or Illnesses or High Visibility Accidents, property damage equal to or greater than \$2,000, or any weight handling equipment accident. Include contractor name; contract title; type of contract; name of activity, installation or location where accident occurred; date and time of accident; names of personnel injured; extent of property damage, if any; extent of injury, if known, and brief description of accident (e.g., type of equipment being used, PPE used). Preserve the conditions and evidence on accident site until the Govt investigation team arrives and Govt investigation is conducted.

## **4 CONTRACT MEETINGS AND REPORTING**

### **4.1 Kickoff Meeting / Teleconference**

Upon Task Order award, within three weeks host a telephonic Kickoff Meeting with the GTT to establish the responsibilities of parties, to discuss the schedule, and to ensure mutual understanding of the scope. Prepare the meeting agenda. After opening remarks by the COR, lead the discussion of specific project requirements. Generate and submit meeting minutes for COR review and approval. This meeting shall occur prior to contractor personnel starting work.

### **4.2 Concrete Core Preparatory Phase Meeting**

Schedule and hold onsite a preparatory meeting prior to starting Task 1 work. Agenda is to discuss safety, and all technical aspects of Task 1 work.

### **4.3 Progress Meeting/Telcon**

At various times, coordinate and host progress meetings with the GTT. The intent will be to discuss progress, quality, coordination, and mutual understanding. Meetings dates will be determined later. Assume they are telephonic. The COR will notify contractor when meetings are required. Prepare and submit brief minutes of the meetings per Table S.

**5 PROPOSAL**

**5.1 Cost**

Provide a detailed cost proposal for Tasks identified in Table 5.1 required to execute work in this SOW.

**Table 5.1 Cost Proposal**

Task 1 Concrete Sample Acquisition, Repair, Shipping; Mechanical KTR Mobilization	\$
Task 2, Laboratory Testing, Examination, and Reports	\$
Task 3 SME Consulting Work	\$
Administrative Submittals	\$

**5.2 Technical**

Provide proposal with succinct detail that demonstrates understanding and compliance with the principal means and methods. Identify the SME Consultant, mechanical support subcontractor, and test laboratory.

**6 OPTION ITEMS**

In the event quantities of work are required in excess of what is in this SOW, Govt would like to establish unit prices for several Option Items. Should the work become necessary, unit prices will provide the basis for rapid execution of a change. Provide a fully burdened cost for optional work, using the referenced SOW paragraph as the basis for each Option Item, pursuant to the tables below. Option Item prices remain valid for the duration of the period of performance.

Only the Contracting Officer has the authority to authorize Option Item work. Do not proceed with any Option Item work unless the option has been exercised and the work is authorized by the Contracting Officer.

**6.1 Option 1 - External Report Review and Analysis**

Basis for the option work is paragraph External SME Report Analysis.

**Table 6.1 Optional External Report Review**

Type	Unit of Measure	Price
Technical Document	Each	\$
Corrosion or Repair Practices Report	Each	\$

**6.2 Option 2 - Third Party Review Response**

Basis for the option work is paragraph Third Party Review Response.

**Table 6.2 Optional Third Party Review Responses**

Work Item	Type, Unit of Measure	Price
Analysis	Minor, Each	\$
Analysis	Substantial, Each	\$
Review and Response to Comments	Minor, Each	\$
Review and Response to Comments	Substantial, Each	\$
Report Supplement	Minor, Each	\$
Report Supplement	Substantial, Each	\$

**6.3 Option 3 - Electronic Meeting Participation**

Basis for the option work is paragraph Appearance and Participation at Public and Regulatory Agency Meetings.

**Table 6.3 Optional Electronic Meeting Participation**

Type of Involvement	Unit of Measure	Price
Participation, Govt Only	Each Meeting	\$
Participation, Govt + RA	Each Meeting	\$
Participation, Govt + RA + Public	Each Meeting	\$

**6.4 Option 4 - SME Consultant Mobilizations**

Basis for the optional work is paragraph Mobilizations.

**Table 6.4 Optional Mobilization**

Type of Participation	Unit of Measure	Price
Onsite Meeting	Each	\$

**6.5 Option 5 - Laboratory Testing**

Basis for the optional work is paragraph Laboratory Testing and Examination.



**Table 6.5 Optional Laboratory Work**

Type	Unit of Measure	Price
Engineer	Hour	\$
Chemist	Hour	\$
Petrographer	Hour	\$
SEM/EDS	Hour	\$
Technician	Hour	\$

**7 GOVERNMENT FURNISHED INFORMATION**

1. DBIDS for JBPHH
2. SECNAV 5512-1
3. FLCPH Badging Flow Charts
4. JB2 0-180
5. Task Order Specifications
6. Submittal Register
7. Concrete Core Information Form

**8 PLACE OF PERFORMANCE**

RHBFSF, Joint Base Pearl Harbor Hickam, Honolulu, Hawaii.

**9 PERIOD OF PERFORMANCE**

The anticipated period of performance is estimated to be 16 months from date of award.

**10 PRIMARY POINTS OF CONTACT**

Contracting Officer

Mr. Sal Vargas  
NAVFAC EXWC Code ACQ72  
1100 23rd Avenue, Building 1100, Port Hueneme, CA 93043-4347  
(805) 982- 2565  
salvador.r.vargas1@navy.mil

Government Technical Team

Project Manager

Ms. Terri Regin  
NAVFAC EXWC Code CI112  
720 Kennon Street, S.E. Suite 333  
Washington Navy Yard, DC 20374  
DSN: 288-5196  
Phone: (202) 433-5196

terri.regin@navy.mil

Project Engineer

Mr. Patrick Hauk

NAVFAC EXWC Code CI112

1000 23<sup>rd</sup> Avenue

Port Hueneme, CA 9304DSN: 288-5196

(805) 982- 1187

patrick.hauk@navy.mil

Design Manager, COR

Mr. Frank Kern

NAVFAC EXWC Code CI112

1000 23<sup>rd</sup> Avenue

Port Hueneme, CA 93043

(805) 982- 2149

frank.kern@navy.mil

## 11 GLOSSARY

ACI	American Concrete Institute	EXWC	Engineering and Expeditionary Warfare Center
API	American Petroleum Institute	FLCPH	Fleet Logistics Center Pearl Harbor
ASCE	American Society of Civil Engineers	GTT	Government Technical Team
ASTM	American Society for Testing and Materials	Govt	Government
CAC	Common Access Card	GFI	Government Furnished Information
CD	Compact Disc	JBPHH	Joint Base Pearl Harbor Hickam
COR	Contracting Officer's Representative	KTR	Contractor
DBIDS	Defense Biometric Identification System	NAVFAC	Naval Facilities Engineering Command
DoD	Department of Defense	SEM	Scanning Electron Microscope
DLA	Defense Logistics Agency	SOW	Statement of Work
EDS	Energy-Dispersive X-ray Spectroscopy	USACE	US Army Corps of Engineers

**END STATEMENT OF WORK**

**Table S Submittal List, Schedule, and Distribution**

Submittal Description	Submittal Schedule			Distribution
	Initial	Govt. Review	Final	
Incident Reports	24 hrs after	-	-	EC
Project Schedule	3 WACA	1 week	-	EC
SME Consultant Resume	3 WACA	1 Week	-	EC
Safety Plan	3 WACA	2 weeks	1 WAGR	EC
Meeting Minutes	2 BD after	-	-	EC
Laboratory Report	1 WACO	1 Week	1 WAGR	EC
Concrete Assessment Report	1 WACO	2 Week	2 WAGR	EC
External Report Review	1 WACO	1 Week	-	EC
Third Party Review Responses	1 WACO	1 Week	-	EC
As Found in Task Order Specifications (Submittal Register)	-	-	-	EC

Legend / Notes:

WACA – Weeks after Contract Award

WACO – Weeks after Completion of Applicable Work

WAGR – Weeks after Govt Review

BD – Business Days

EC – Electronic Copy, subject to format / e-mail size requirements specified in the SOW

HC – Hard Copies, quantity four (4). Each hard copy shall include a CD/DVD insert including electronic copies of the report. contractor shall provide another eight (8) electronic copies of the report on CD/DVD

[1] – Weekly reports shall be e-mailed by 1000 local time of the first following business day

**APPENDIX E**  
**Proposal - Inspect and Repair Protocols Project for Red Hill**  
**Underground Storage Tanks**

This Page is Intentionally Left Blank.

Inspect and Repair Protocols Project  
for Red Hill Underground Storage Tanks (IRPP RhUST)

Lloyd Hihara

14 February 2020

Hawaii Corrosion Laboratory  
Department of Mechanical Engineering  
Holmes Hall 302  
College of Engineering  
University of Hawaii at Manoa  
2540 Dole St., Honolulu, Hawaii 96822  
Telephone: (808) 956-2365  
e-mail: [hihara@hawaii.edu](mailto:hihara@hawaii.edu)

## Inspect and Repair Protocols Project for Red Hill Underground Storage Tanks (IRPP RhUST)

L.H. Hihara

IRRP RhUST proposes to 1) elucidate the limits of nondestructive evaluation on severely corroded steel panels with adherent corrosion products, 2) determine in situ corrosion rates of the steel shell of the Red Hill underground fuel storage tanks (USTs), and 3) evaluate repair and patch protocols to prevent premature failures.

Low-frequency electromagnetic testing (LFET) is frequently used to examine the remaining wall thickness of the UST steel shell plates. Thick, adherent steel corrosion products (i.e., magnetite) on the back side of the plates could affect the LFET signals and indicate remaining wall thicknesses greater than actual values. To study the extent of which magnetite and other steel corrosion products can affect LFET signals, control test panels will be fabricated by generating an array of pits of varying geometries and sizes. Three dimensional profilometry scans will be conducted on the plates to generate three-dimensional scans of the defects, which can be later compared to LFET scans. The defects in the control panels will then be backfilled with magnetite as well as other types of rust corrosion products (e.g., goethite, lepidocrocite). The coupons with the backfill corrosion products will be later scanned using LFET and compared to the previous LFET scans (prior to back filling the defects) and compared to the 3-dimensional profilometry scans. This will determine the limits of LFET to accurately identify and screen corrosion pits on plates with adherent backside corrosion products. Ideally, additional allowances for the presence of magnetite etc. can be identified and incorporated into minimum wall thickness thresholds. The LFET scanning may be completed in a follow-on phase of this project.

Currently, the real time corrosion rates of the steel shell of the Red Hill USTs are unknown. The actual corrosion rate is needed to determine safe time intervals between scheduled maintenance. A protocol for measuring in situ corrosion rates of the UST walls will be developed and tested in the laboratory which can then be successfully applied to the actual USTs. The actual implementation to measure the corrosion rates in situ at Red Hill will depend on access to out-of-service USTs in which locations of corrosion pits are known (by prior NDE screening), and may have to be conducted on a follow-on phase.

Since steel corrosion products are expansive and can bend metal and fracture concrete, the current repair and patch protocols will be re-examined to minimize premature failures. Patch plate coupons will be fabricated and subjected to accelerated corrosion testing to gain insight on likely failure modes. The repair and patch protocols will be redesigned if necessary to maximize life expectancy. In this phase of the project, repair protocols will be studied, accelerated test coupons will be fabricated, and accelerated corrosion testing will be initiated. Study of the failure modes and modeling may be completed in a follow-on phase.

If the above tasks are successfully completed and implemented in the operation of the USTs, a more accurate assessment of the minimum wall thickness and real time corrosion rates will allow more accurate inspection and repair intervals to be determined. Improvements made to the current patch protocols may help to enhance the life expectancy of the UST wall.

The risk are low as the research will not involve compromise to the USTs. The cost for this phase of the project is \$750k (Personnel \$385k, Materials and Supplies \$18k, Equipment \$160k, Travel \$2k, Overhead 185k), and proposed to be completed within approximately one year. Progress can be measured on an incremental basis by determining if the milestones on the attached Gantt chart are met.



# Inspect and Repair Protocols Project for Red Hill UST

PI: Lloyd Hihara / University of Hawaii at Manoa

## Objective

The proposed work is the clean, inspect, and repair category:

- 1) Understand the limits of non-destructive evaluation (NDE) (e.g., low-frequency electromagnetic technique (LFET)) on severely corroded steel panels with adherent backside corrosion products.
- 2) Understand the operating corrosion mechanisms of the underground storage tank (UST) steel shell, and obtain in situ corrosion rates. Determine if corrosion rates are stable, decelerating, or accelerating.
- 3) Evaluate repair and patch protocols to prevent premature failures. Since steel corrosion products are expansive and can bend metal and fracture concrete, the current repair and patch protocols should be examined under accelerated testing conditions to anticipate failure modes.

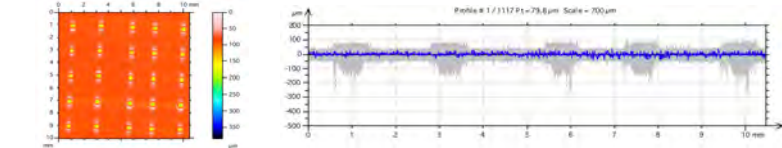

Figure 1: Example 3D and 2D profilometry scans to be compared with NDE scans.

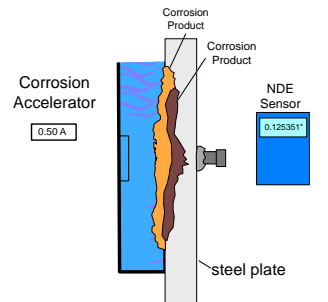

Figure 2: Mounted NDE sensor to determine in situ corrosion rates (proof of concept).

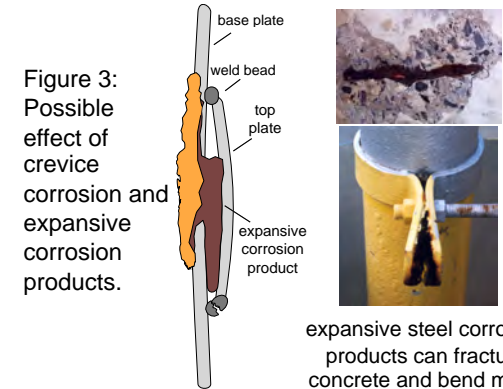

Figure 3: Possible effect of crevice corrosion and expansive corrosion products.

expansive steel corrosion products can fracture concrete and bend metal

## Approach

- 1) Fabricate control steel plate specimens with defects of different sizes and geometries that are backfilled with different types of rust (e.g., magnetite, goethite, lepidocrocite). Compare 3D profilometry scans to NDE scans. The samples will be used in future LFET examinations.
- 2) Measure backside corrosion rates on laboratory corrosion coupons utilizing ultrasonic sensors for proof of concept. Apply in the future to out-of-service USTs
- 3) Fabricate welded patch-plate coupons for accelerated corrosion testing, and study failure modes.

## Key Milestones

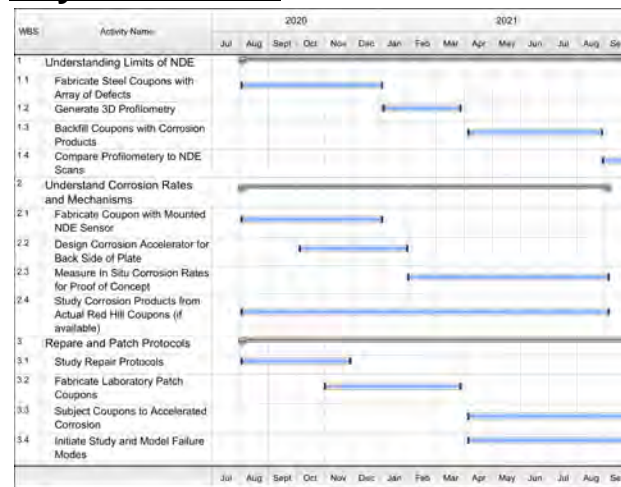

This Page is Intentionally Left Blank.

**APPENDIX F**  
**Proposal - Concrete Tank Degradation Inspection and Retrofit**

This Page is Intentionally Left Blank.

RED HILL BULK FUEL STORAGE FACILITY  
NAVFAC/NAVSUP  
**Concrete Tank Degradation Inspection and Retrofit**

Contact: Lin Shen  
Dept. Civil and Environmental Engineering  
2540 Dole Street, Holmes Hall 383  
Honolulu, Hawaii 96822  
email: [linshen@hawaii.edu](mailto:linshen@hawaii.edu)

The objectives of this portion (secondary containment-corrosion in concrete) of the project are to 1) identify the locations and extent of cracking/degradation of the concrete and steel structure surrounding the oil tanks, 2) understand the causes and mechanism of the concrete and steel degradation based on chemical and mineralogical analysis, and 3) propose appropriate retrofitting technologies and strategies.

1) Identify locations/extents of concrete degradation

This phase will be conducted based on the findings of from the “Inspection” part of this project, where drones carrying ultrasonic, infrared, and electromagnetic sensors can provide information about the general location and extent of deterioration. Several locations will then be selected and state-of-art inspection techniques such as Half-Cell Potential (for steel corrosion probability), linear polarization method (for corrosion rate), and ground penetrating radar will be performed to get the detailed information about concrete degradation and steel corrosion. Small samples will also be collected for further lab analysis in the next phase .

2) Using chemical and mineralogical analysis of cored sample to evaluate the causes of degradation

Samples will be analyzed in the lab based on petrographic analysis, Scanning Electron Microscopy (SEM)-with Energy-Dispersive X-Ray Spectroscopy (EDS), X-Ray Diffraction, Mercury Intrusion Porosimetry, etc.



**Fig1. Scanning Electron Microscopy (SEM)- with Energy-Dispersive X-Ray Spectroscopy (EDS)**

There are many potential reasons for leakage and degradation of concrete and steel degradation. For example, leakage may be caused by cracking of concrete due to reaction between chemicals in the soil/ground water and concrete, or cracking due to corrosion of reinforcement, or cracking due to reactive aggregate of the concrete. The exact causes and severity of concrete and steel degradation will be identified in phase 2.

3) Propose appropriate retrofitting technologies based on the findings from 1) and 2).

Appropriate retrofitting technologies will be proposed by identifying the exact causes and extent of concrete and steel degradation based on the field inspection and laboratory analysis, and by considering the actual constructability of various retrofitting techniques for the Red Hill Fuel Storage system. For example, if voids and cracking are found responsible for leakage and degradation, low-viscosity monomers maybe injected to seal cracks and voids which are unreachable from conventional repair strategies. For repair of corroded steel layer, information about speed, probability, and extent of corrosion will greatly facilitate future retrofitting plan.

## Red Hill Project – 2 Secondary Containment (corrosion in concrete)

PI: Lin Shen / University of Hawaii at Manoa

### Objective

The objectives of this portion (secondary containment-corrosion in concrete) of the project are to 1) identify the locations and extent of cracking/degradation of the concrete structure surrounding the oil tanks, 2) understand the causes and mechanism of the concrete degradation based on chemical and mineralogical analysis, and 3) propose appropriate concrete retrofitting technologies and strategies.

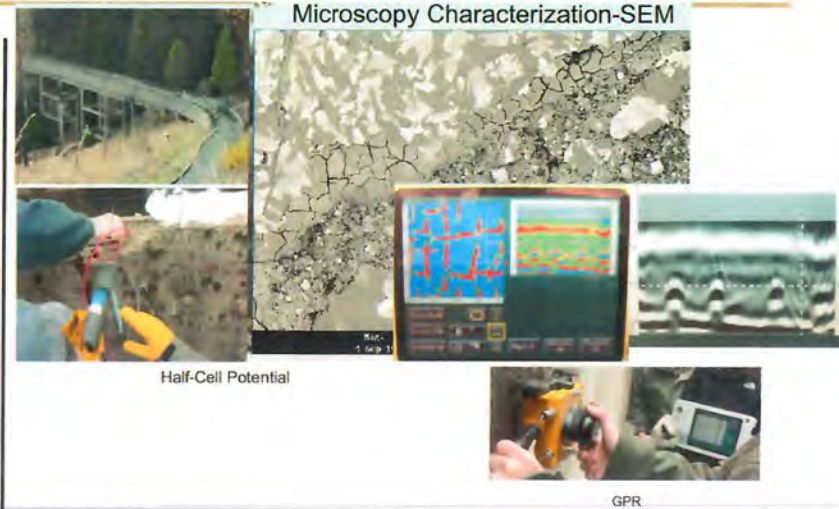

### Approach

- 1) Identify locations/extents of concrete degradation based on the findings of PIs from the "Inspection" part of this project together with state-of-art concrete inspection techniques such as Half-Cell Potential and ground penetrating radar;
- 2) Using chemical and mineralogical analysis of cored sample to evaluate the causes of degradation;
- 3) Propose appropriate retrofitting technologies based on the findings from 1) and 2).

**Co-Is/Partners:** David Ma, Ian Robertson, Roger Babcock, Lloyd Hihara et al.

### Key Milestones

- Milestone #1 Identify locations/extents of concrete degradation  
6 month after NTP
- Milestone #2 Analyze samples and evaluate causes of degradation  
12 months after NTP
- Propose appropriate retrofitting technologies and strategies  
18 mon after NTP



This Page is Intentionally Left Blank.



**APPENDIX G**

**Proposal - Element, Phase, and Oxidation State Mapping of Red Hill  
UST Corrosion by Advanced Microscopy Methods**

This Page is Intentionally Left Blank.

# Red Hill Corrosion Monitoring for Mitigation: Element, Phase, and Oxidation State Mapping

## White Paper on the Red Hill Bulk Fuel Storage Facility

PI: Dr. Hope Ishii, [hope.ishii@hawaii.edu](mailto:hope.ishii@hawaii.edu), HIGP POST 602, 1680 East-West Rd, Honolulu, HI  
Organization: Advanced Electron Microscopy Center, University of Hawai'i at Mānoa

Corrosion is a fluid-mediated redox phenomenon that modifies oxidation state, structure, and composition. It often initiates around nanoscale defects, rapidly propagates, and ultimately leads to failure. Fuel tanks located in the Red Hill Bulk Fuel Storage Facility (U.S. Navy) regularly undergo non-destructive examination methods to monitor the effects of corrosion and metal fatigue. Recently, destructive testing was also performed, and the impact of corrosion on tank wall thickness was measured in coupons extracted at the exterior surface in contact with the concrete casing [1]. The analyses validate the current non-destructive methods, but the underlying corrosion problem has yet to be addressed. The local water source(s)/pathway(s), and specific corrosion mechanism(s) that result, are not yet well understood. The current solution is a literal Band-Aid: Where a tank wall has lost thickness due to corrosion, an extra layer of steel is welded in place to retain structural integrity. The Navy's ongoing interest in improving fuel storage has resulted in discussions of upgrades and new fuel tank designs, and we propose to contribute to these future improvements and to ongoing corrosion mitigation efforts with improved understanding of the corrosion mechanisms operating in existing tanks.

We propose three objectives: 1) Determine the micrometer-scale corrosion pathways and roles of indigenous/induced structural defects; 2) Search for foreign corrosive species, check for concentration and/or oxidation state gradients, and seek their source(s) in local materials; and 3) Assess the possibility of distinguishing historic from contemporary corrosion episodes.

We will characterize fuel tank samples using state-of-the-art electron and ion beam instruments, unique in the State of Hawai'i. They are a focused ion beam-scanning electron microscope (FIB-SEM, Fig. 1) with energy dispersive x-ray spectrometer (EDS) and a scanning transmission electron microscope (S/TEM) with electron energy-loss spectrometer (EELS) and EDS (Fig. 2). They provide images and spectral maps for visualizing structure and morphology as well as corrosion product distribution, phases, compositions, and oxidation states in sample regions of centimeters down to the nanoscale. See attached quad chart.

**Figure 1:** The FIB-SEM, interior schematic, and examples of element mapping by EDS, site-specific cross-section by FIB for mapping, and coupon extraction for S/TEM imaging.

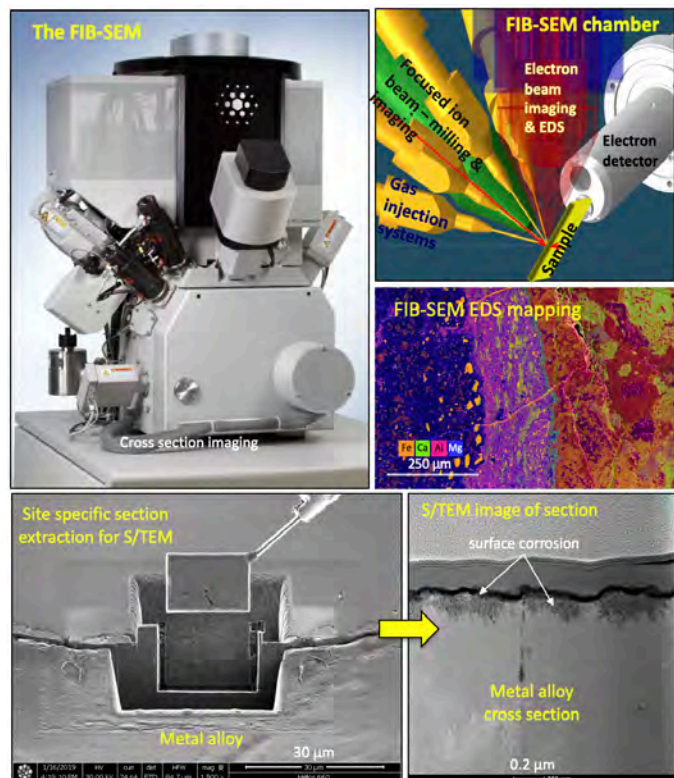

Specifically, we will first image and map element composition on large areas of corroded surfaces for overall chemistry and morphology. This low- to high-magnification approach mitigates the risk of focusing on non-representative regions. We will then generate cross-section, image, and map compositions of the corroded interface to investigate the relationship of corrosion to defects that may facilitate corrosion (delamination, fractures, grain boundaries, manufacturing defects, etc.), assess local scale corrosion depth and material loss, determine corrosion product phases, and assess foreign corrosive species that may act as “tracer” elements to fingerprint water pathways and distinguish old from new corrosion. Gradients in “tracer” species, if present, will be mapped, and additional analyses materials surrounding the tank (e.g. concrete casing, gunite, basalt bedrock) may lead us to the source(s) of those species. For a selected subset of samples, we will extract micrometer-sized coupons in cross-section in order to obtain high-resolution imaging, element maps, and oxidation state maps in corrosion products. We will map the oxidation states of iron as well as those of “tracer” elements.

We propose to study coupons from multiple regions in the tank to ensure robust and statistically significant findings. For cost and time estimates, we assume a total of 6-8 coupons. If all coupons are allocated at the project start, we estimate that work can be completed within 6 months. Initial analysis by SEM and EDS typically requires 1-2 hrs/sample (depending on sample dimensions). Based on the initial analyses, a subset of coupons will be subjected to higher spatial resolution analysis and oxidation state analysis: Site-specific, electron-transparent coupons will be extracted using the FIB, a process that typically requires 4-6 hrs. These will be characterized by S/TEM-EDS and -EELS, typically 1-2 hrs/sample. The fee for SEM-FIB is \$110 per hour and STEM-EDS and -EELS is \$160/hr. Total project cost and duration will depend on total number of samples provided.

We expect our proposed investigation to provide significant insights into the underlying cause(s) and mechanisms of corrosion of the Red Hill tanks, key input for design of future tanks, and a potential way to determine if corrosion is historic or contemporary. Our team (Ishii, Bradley and Ohtaki) has extensive experience in characterization of weathering and corrosion phenomena in metals, alloys, ceramics (including concretes), and geological materials.

**References:** [1] T.N. Ackerson and J. Breetz (IMR test lab) “Destructive Analysis of 10 Steel Coupons Removed from Red Hill Fuel Storage Tank #14” Report No. 201801967 (2018). [2] K.K. Ohtaki, J.P. Bradley, H.A. Ishii “Combined focused ion beam-ultramicrotomy method for TEM specimen preparation of porous fine-grained materials.” *Microsc. Microanal.* doi: 10.1017/ S1431927619015186 (2019). [3] G.B. Freeman, B.R. Livesay, J.P. Bradley et al. “Intermetallic embrittlement of thin unsupported tin/copper specimens”, *J. Electronic Mat.* 23 (9), 1-7 (1994). [4] T.A. Abrajano, J.K. Bates, J.P. Bradley, “Analytical Electron Microscopy of Leached Nuclear Waste Glasses,” *Ceramic Trans.* 9, 211-228 (1990). [5] C. Zevenbergen, J.P. Bradley et al., “Natural weathering of MSW bottom ash in a disposal environment.” *Microbeam Analysis* 3, 125-135 (1994). [6] Graham G.A. et al. “Applied focused ion beam techniques for sample preparation of astromaterials for integrated nano-analysis.” *Meteor. Planet. Sci.* 43, 561-569 (2008).

**Figure 2:** S/TEM imaging and oxygen EELS spectrum demonstrating hydration.

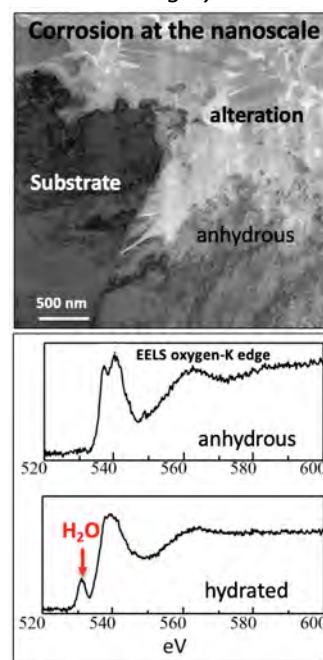



# Red Hill Corrosion Monitoring for Mitigation: Element, Phase, and Oxidation State Mapping

PI: Dr. Hope Ishii / Advanced Electron Microscopy Center, U. Hawai'i at Mānoa

## Objectives

1. Determine the micrometer-scale corrosion pathways and roles of indigenous and induced structural defects (surface delamination, intrusion at fractures, grain boundaries, or manufacturing defects, etc.).
2. Search for foreign corrosive species (“tracers”), check for concentration and/or oxidation state gradients, and seek their source(s) among local materials (concrete liner, gunite, local bedrock).
3. Assess the possibility of distinguishing between historic and contemporary corrosion episodes.

## Approach

1. Cut steel coupons, polish in cross-section
2. Collect electron micrographs and elemental maps with full X-ray spectrum at each pixel, first on surface, then in cross-sections
3. Extract maps of “tracer” elements, e.g. Na, K, P, Cl, S
4. Analyze local materials, as appropriate
5. Perform S/TEM oxidation state maps
6. Compare chemical maps (elemental and oxidation state) across different locations
7. Compile imaging and map data to assess corrosion pathways, tracer elements, and episodic corrosion

**Co-Is/Partners:** Dr. Kenta Ohtaki and Dr. John Bradley

## Electron imaging & element and oxidation state mapping

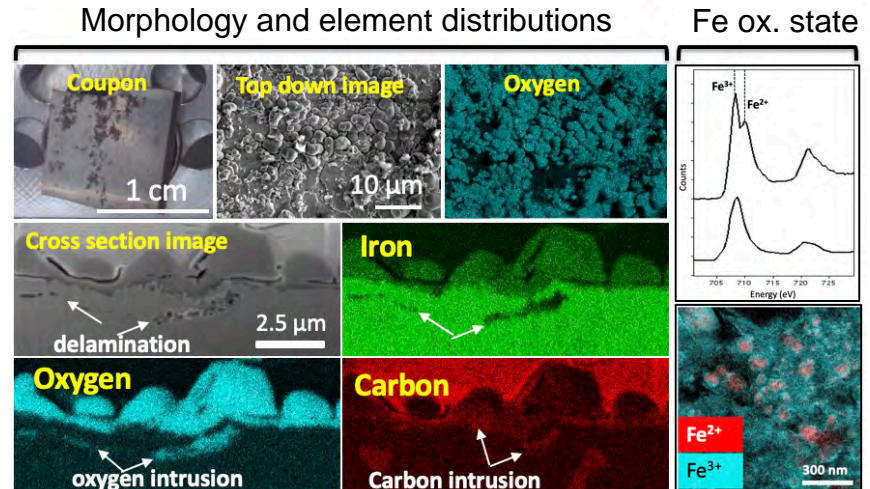

## Key Milestones

- |   | <u>Estimated completion*</u> |
|---|------------------------------|
| • Project start   | $t_0$                        |
| • Sample preparation  | $t_0 + 2$ weeks              |
| • Imaging & Mapping of initial sample set                               | $t_0 + 1.5$ months           |
| • Feedback on additional sample locations                               | $t_0 + 1.5$ months           |
| • Imaging & Mapping of follow-up samples                                | $t_0 + 3$ months             |
| • High resolution imaging, element mapping, and oxidation state mapping | $t_0 + 4$ months             |
| • Report on “tracer” elements and episodic corrosion                    | $t_0 + 6$ months             |
| • Report on corrosion pathways  | $t_0 + 6$ months             |

\* Assumes 6-8 samples



This Page is Intentionally Left Blank.

**END OF DOCUMENT**

This page intentionally left blank



Appendix B:  
Red Hill Fuel Storage Facility (RHFSF) Response Plan

This page intentionally left blank

---

**COMMANDER NAVY REGION  
HAWAII (CNRH)**



**RED HILL FUEL STORAGE FACILITY  
(RHFSF)  
RESPONSE PLAN**

FOR OFFICIAL USE ONLY (FOUO)

August 2020

---

THIS PAGE INTENTIONALLY LEFT BLANK

## TABLE OF CONTENTS

	Page
Table of Contents .....	i
Record of Changes/Review.....	vii

### RED PLAN

<b>RP.1 CRITICAL ACTIONS FOR RHFSF FUEL LEAK EMERGENCY .....</b>	<b>RP-1</b>
<b>RP.2 FUEL DEPARTMENT PERSONNEL ACTION .....</b>	<b>RP-2</b>
RP.2.1 Underground Pumphouse Area.....	RP-2
RP.2.2 Red Hill Area .....	RP-2
RP.2.3 Waste Oil Tanks B1 & B2 .....	RP-4
<b>RP.3 EMERGENCY PHONE LISTS.....</b>	<b>RP-4</b>
<b>RP.4 SPILL INFORMATION LOG .....</b>	<b>RP-5</b>

### MAIN PLAN

<b>1.0 INTRODUCTION.....</b>	<b>1-1</b>
1.1 Plan Purpose.....	1-1
1.2 Plan Organization.....	1-1
1.3 References.....	1-2
<b>2.0 FACILITY INFORMATION .....</b>	<b>2-1</b>
2.1 Facility Location .....	2-1
2.2 Facility Description.....	2-4
2.3 Underground Pumphouse.....	2-8
2.4 Red Hill Diesel Power Plant (Abandoned) .....	2-8
<b>3.0 FACILITY HISTORY.....</b>	<b>3-1</b>
3.1 Initial Planning.....	3-1
3.2 Facility Design.....	3-1
3.3 Construction.....	3-2
3.4 Quantities Involved in Building the Red Hill Tanks .....	3-4
3.5 Quick Facts on Red Hill.....	3-4
3.6 References.....	3-13
<b>4.0 FIRE AND SAFETY SYSTEMS.....</b>	<b>4-1</b>
4.1 Introduction.....	4-1
4.2 Fire Alarm System .....	4-1
4.3 Emergency Oil Pressure Door .....	4-3
4.4 Facility Access .....	4-4

<b>5.0</b>	<b>LEAK DETECTION .....</b>	<b>5-1</b>
5.1	Past Leak Detection Methods .....	5-1
5.2	Current Leak Detection Methods.....	5-1
<b>6.0</b>	<b>ENVIRONMENTAL SETTING .....</b>	<b>6-1</b>
6.1	Surrounding Population .....	6-1
6.2	Land Use and Zoning.....	6-1
6.3	Soils.....	6-2
6.4	Geology.....	6-2
<b>7.0</b>	<b>ENVIRONMENTALLY SENSITIVE AREAS.....</b>	<b>7-1</b>
7.1	Local Flora.....	7-1
7.2	Threatened and Endangered Species and Critical Habitat.....	7-1
<b>8.0</b>	<b>GROUNDWATER AND HYDROLOGY .....</b>	<b>8-1</b>
8.1	Surface Water.....	8-1
8.2	Groundwater Usage .....	8-1
8.3	Aquifers and Groundwater Movement .....	8-1
8.4	Groundwater Protection Plan.....	8-2
8.5	Groundwater Monitoring Program .....	8-2
8.6	Soil Vapor Monitoring System .....	8-3
8.7	Groundwater Model Simulations.....	8-4
<b>9.0</b>	<b>SITE SAFETY INFORMATION.....</b>	<b>9-1</b>
9.1	General Safety Information.....	9-1
9.2	Medical Monitoring.....	9-1
9.3	Primary Chemical Hazards .....	9-1
9.4	Secondary Chemical Hazard Identification .....	9-3
9.5	Physical Hazards.....	9-5
9.6	Heat Stress Information .....	9-9
9.7	Site Safety Plan Information.....	9-15
9.8	PPE Levels of Protection .....	9-16
9.9	Manifestations of Toxic Effects to Various Target Organs .....	9-16
9.10	Safety Data Sheets .....	9-17
<b>10.0</b>	<b>RESPONSE EQUIPMENT RESOURCES .....</b>	<b>10-1</b>
10.1	Navy Resources .....	10-1
10.2	Response Personnel .....	10-11
10.3	Navy SUPSALV .....	10-12
10.4	Commercial Resources .....	10-21
10.5	State Resources .....	10-21
10.6	Federal Response Resources.....	10-21

<b>11.0</b>	<b>WASTE MANAGEMENT AND DISPOSAL PROCEDURES.....</b>	<b>11-1</b>
11.1	Responsibility .....	11-1
11.2	Waste Collection, Management, and Disposal Process .....	11-2
11.3	Temporary Storage for Collected Oil and Response Waste .....	11-4
11.4	Waste Container Management.....	11-5
11.5	Disposal Conditions and Criteria .....	11-6
11.6	General Waste Handling and Disposal Methods .....	11-7
11.7	Non-Hazardous Waste Disposal Methods .....	11-10
11.8	Recyclable Material .....	11-10
11.9	Annual Solid Waste Disposal Documentation.....	11-10
<b>12.0</b>	<b>EVACUATIONS.....</b>	<b>12-1</b>
12.1	Notification of Serious or Facility-Wide Emergency Situation.....	12-1
12.2	Primary and Secondary Evacuation Routes .....	12-1
12.3	General Emergency Evacuation Procedures .....	12-2
<b>13.0</b>	<b>REFERENCES.....</b>	<b>13-1</b>

### SCENARIO TABS

#### **TAB A - WORST-CASE DISCHARGE SCENARIO**

1.0	WORST-CASE DISCHARGE SCENARIO .....	A-1
1.1	Introduction.....	A-1
1.2	Actions to Prevent a Worst-Case Discharge.....	A-1
1.3	Fuel Escaping Adit 2.....	A-2
1.4	Fuel Movement on Water .....	A-3
2.0	IMMEDIATE RESPONSE ACTIONS .....	A-3
2.1	Fuel Department Personnel.....	A-3
2.2	Control Room Operator .....	A-3
2.3	Fuel Director/Emergency Coordinator .....	A-3
2.4	Navy On-Scene Coordinator.....	A-4
2.5	Safety Officer.....	A-4
3.0	INITIAL RESPONSE.....	A-4
4.0	RESPONSE STRATEGIES .....	A-5
4.1	For Oil Escaping and Remaining in the Tunnel.....	A-5
4.2	For Oil that Directly Impacts the Water .....	A-6
4.3	Containment and Oil Recovery Booming Strategy for Halawa Stream .....	A-6
4.4	Spill Trajectory .....	A-10
4.5	Oil Weathering.....	A-10

**TAB B – MAXIMUM MOST PROBABLE DISCHARGE SCENARIO**

1.0	MAXIMUM MOST PROBABLE DISCHARGE SCENARIO .....	B-1
1.1	Introduction.....	B-1
2.0	IMMEDIATE RESPONSE ACTIONS .....	B-1
2.1	Fuel Department Personnel.....	B-1
2.2	Control Room Operator .....	B-1
2.3	Fuel Director/Emergency Coordinator .....	B-2
2.4	Navy On-Scene Coordinator.....	B-2
2.5	Safety Officer.....	B-2
3.0	INITIAL RESPONSE.....	B-2
4.0	RESPONSE STRATEGIES .....	B-3

**APPENDICES**

APPENDIX A	NOTIFICATIONS
APPENDIX B	FINANCIAL RESPONSIBILITY
APPENDIX C	SPILL INFORMATION LOG
APPENDIX D	WASTE MANAGEMENT AND DISPOSAL PLAN
APPENDIX E	SAFETY DATA SHEETS
APPENDIX F	FRAME FOOT MARK SPREADSHEET
APPENDIX G	ACRONYMS

**TABLES**

Table RP.1	NAVSUP FLCPH Oil Spill Response Team .....	RP-4
Table RP.2	CNRH Spill Emergency Response/Cleanup Teams .....	RP-5
Table RP.3	Navy SUPSALV/Spill Response Contractors .....	RP-5
Table 2.1	RHFSF Tank Inventory.....	2-5
Table 9.1	Permissible Exposure Limits of Products Stored at RHFSF .....	9-1
Table 9.2	Secondary Chemical Hazards .....	9-3
Table 9.3	General Physical Hazards .....	9-5
Table 9.4	Permissible Noise Exposure .....	9-8
Table 10.1	Firefighting and Crash Fire Rescue Equipment.....	10-1
Table 10.2	Heavy Equipment.....	10-3
Table 10.3	Sorbents and Spill Kits.....	10-6
Table 10.4	Vacuum Trucks.....	10-8
Table 10.5	Skimmers .....	10-9
Table 10.6	Response Vessels.....	10-10
Table 10.7	Boom.....	10-10
Table 10.8	Temporary Waste Oil Storage .....	10-11



Table 10.9	Facility Response Team.....	10-11
Table 10.10	Navy SUPSALV Oil Spill Response Equipment .....	10-12
Table 10.11	Spill Response Contractors.....	10-21
Table 10.12	Commercial Barge Services.....	10-21
Table 10.13	Federal Special Teams.....	10-22
Table 11.1	Material Classification and Disposal Strategy.....	11-3
Table 11.2	Temporary Storage for Collected Oil and Response Waste .....	11-4
Table 11.3	Waste Container Codes.....	11-6
Table 11.4	Disposal Strategy, Disposal Criteria, and Conditions.....	11-7
Table A.1	Evaporation Rates for F-76 over Time .....	A-10

### FIGURES

Figure RP.1	Location of Sluice Valve for Impoundment Area outside Adit # 1.....	RP-3
Figure RP.2	Lower Access Tunnel Sump below Tanks 1 and 2 .....	RP-3
Figure 2.1	RHFSF Location .....	2-1
Figure 2.2	Topographic View of the RHFSF .....	2-2
Figure 2.3	Three-Dimensional View of the RHFSF .....	2-3
Figure 2.4	RHFSF Schematic.....	2-7
Figure 3.1	Red Hill Design Concept .....	3-5
Figure 3.2	Side Hill Entrance to Tank Excavations .....	3-6
Figure 3.3	Chamber Excavation Schematic .....	3-7
Figure 3.4	Tank Excavation Process .....	3-8
Figure 3.5	Lower Tank Dome under Construction .....	3-9
Figure 3.6	Construction of Tank Walls.....	3-10
Figure 3.7	Lining the Walls of the Tank Chamber.....	3-11
Figure 3.8	Tank Construction Details .....	3-12
Figure 4.1	Emergency Oil Pressure Door .....	4-4
Figure 6.1	Zoning Map.....	6-3
Figure 6.2	Geologic Map of Oahu.....	6-4
Figure 8.1	Land Use and Stream Locations in Relation to the RHFSF .....	8-5
Figure 8.2	Oahu's Aquifer Sectors.....	8-6
Figure 8.3	Area Wells and Aquifer Systems.....	8-7
Figure 8.4	Regional Groundwater Flow by Aquifers.....	8-8
Figure 8.5	Groundwater Monitoring Well Locations.....	8-9
Figure 9.1	Heat Stress Index .....	9-14
Figure 11.1	Waste Container Labels .....	11-5
Figure 12.1	RHFSF Emergency Evacuation Zones .....	12-3
Figure A.1	Drainage Map of Area around Adit 2 .....	A-2
Figure A.2	Aerial Photo Showing Location of Adit 2 .....	A-5

Figure A.3 Staging Area, Mike 1 and 2 Piers ..... A-8  
Figure A.4 Staging Area at Facility Response Team Base, Ford Island..... A-8  
Figure A.5 Aerial Photo Depicting the Booming Strategy and Oil Recovery Sites ..... A-9  
Figure A.6 Nautical Chart Depicting the Booming Strategy and Oil Recovery Sites ..... A-9  
Figure A.7 NOAA Oil Weathering Model for F-76 Spill..... A-10  
Figure B.1 Aerial Photo Showing Staging Area outside Adit 3 .....B-3

## RECORD OF CHANGES/REVIEW

To ensure up-to-date information, this response plan shall be periodically reviewed and updated to reflect changes at the RHFSF. The following table should be used to indicate that periodic reviews have been completed and to record any changes made. This record should be retained in this plan.

<b>RECORD OF CHANGES</b>		
<b>Date</b>	<b>Change Posted By</b>	<b>Summary of Change</b>
August 2020	Justin Wilson, PCCI, Inc.	General Updates - reorganized existing sections and created new ones (see below) - updated names, commands, and phone numbers - many small edits and grammatical corrections
“	“	Section 1, Introduction - minor edits, added subsections 1.2 and 1.3.
“	“	Section 2, Facility Information - updated section 2.2 (facility description) - added features to Figure 2.4 - deleted section on “red hill oily waste pit” as it no longer exists
“	“	Section 3, Facility History - minor edits - added sections 3.4 and 3.5
“	“	Section 4, Fire and Safety Systems - new section
“	“	Section 5, Leak Detection - new section
“	“	Section 6, Environmental Setting - reorganized section - added subsection (6.2) on land use and zoning - new figures 6.1 and 6.2
“	“	Section 7, Environmentally Sensitive Areas - minor edits
“	“	Section 8, Groundwater and Hydrology - new section
“	“	Section 9, Site Safety Information - minor edits
“	“	Section 10, Response Resources - updated all equipment listing tables - expanded “response personnel”, section 10.2 - updated listings and phone numbers for sections 10.4 and 10.6
“	“	Section 11, Waste Management and Disposal - minor edits - updated phone numbers
“	“	Section 12, Evacuations - updated all section to reflect facility improvements
“	“	Section 13, References - checked and updated references

<b>RECORD OF CHANGES</b>		
<b>Date</b>	<b>Change Posted By</b>	<b>Summary of Change</b>
August 2020	Justin Wilson, PCCI, Inc.	Tabs A & B - updated scenarios to reflect facility improvements such as fire systems, oil proof doors, and communication systems.
“	“	Appendix A, Notifications - checked and updated notifications
“	“	Appendix B, Financial Responsibilities - minor edits - updated phone numbers
v		Appendix C, Spill Information Log - no changes
“	“	Appendix D, Waste Management and Disposal Plan - no changes
“	“	Appendix E, Safety Data Sheets - no change
“	“	Appendix F, Frame Foot Mark Spreadsheet - updated and added features such as fire department hose connections, emergency phones, etc.
“	“	Appendix G, Acronyms - added some new acronyms

## RED PLAN

### RP.1 CRITICAL ACTIONS FOR FUEL LEAK EMERGENCY

A catastrophic fuel leak may be directly observed by personnel in the tunnel or through the use of security cameras that are strategically located throughout the lower tunnel. The other situation that may identify a major fuel leak would be through the Automatic Fuel Handling Equipment (AFHE) Mass Tank Gauging system. If the system registers an unscheduled fuel movement (UFM), the following actions must be taken:

1. The tank in question will be monitored with security cameras and a Gauger/Rover will be sent to the lower tank gallery to inspect the tank area and skin and sectional valves for evidence of leakage or a valve that is not fully shut.
2. The Gauger/Rover will manually close the tank's suction/fill valves and put the valves into high torque.
3. The Gauger/Rover will manually gauge the tank in question.
4. The Control Room Operator will compare the manual reading to the current AFHE reading and annotate any discrepancies.
5. The Control Room Operator will compare the most recent manual gauge to the last recorded manual measurement to determine if the fuel level has changed.
6. If the most recent manual measurement does not match the last manual measurement and there is a decrease in excess of 3/16", the Supervisory Distribution Facilities Specialist, Bulk Fuel Operations Supervisor, Director and Deputy Director will be notified and the Gauger/Rover will conduct manual measurements every four hours until directed otherwise by management.

**For a Catastrophic Fuel Release Notify Control Room Operators at:  
Underground Pumphouse: 471-8081 or 473-1075  
Building 1757: 473-7804 or 473-7837**

#### Control Room Operator shall:

- Notify all workers in the tunnel using the "giant voice" system.
- Notify personnel by radio or telephone to stop all fueling operations.
- Shut down all fuel pumps using the AFHE Emergency Shutdown Graphical User Interface (GUI) or by pressing Ctl+Alt+F1 on the keyboard.
- Close all open valves via AFHE system.
- Stop all maintenance and hot work.
- Call:

Fuel Director (Emergency Spill Coordinator)	473-7833 or cell: 690-0115
Fuel Deputy Director (if unable to reach Fuel Director)	473-7801 or cell: 780-3703
Supervisory Distribution Facilities Specialist	473-7824 or cell: 216-1341
Bulk Fuel Operations Supervisor	473-7805 or cell: 479-1063
Regional Dispatch Center	911 or 471-7117
NAVSUP FLCPH Command Duty Officer (CDO)	473-1310 or cell: 216-1339

Fuel leaking from a bulk storage tank will flow through the LAT towards the Underground Pumphouse (UGPH). Actions to be taken:

- Warn personnel in the area, if necessary.
- Secure the blast door at the gauger station if it is not closed.
- Workers in the Upper Access Tunnel (UAT) will exit through Adit # 4 or Adit # 5.
- Workers in the LAT (below the tanks) will exit through Adit # 3, Adit # 2, or Adit # 1 if working below Adit # 3.
- All exiting workers will call the Control Room Operator at 471-8081/473-1075 (UGPH) or 473-7804/473-7837 (Building 1757) after exiting the facility to report their situation and relay any observation of a fuel spill.
- Any workers who cannot exit for some reason must find the nearest emergency phone (blue boxes) and call for assistance and/or direction.
- Close the “emergency oil pressure door” at the end of the tank gallery in the LAT. The door can be closed by pressing a push button on the bulkhead adjacent to the door.

**Federal Fire Incident Commander shall:**

- Establish an emergency command post outside the Adit # 1 entrance if applicable (and safe) or Building 1757 and verify the location of all workers in the tunnel.

**Emergency Spill Coordinator (or Alternate) shall:**

- Observe security camera feeds at Control Room in Building 1757 to determine source of leak.
- If it is determined that the leak is coming from a tank before the first isolation valve or through an AFHE UFM alarm, direct the Control Room Operator to set up draining of the tank through gravity feed to any available tanks with ullage.
- If leak is coming from pipeline, leave all valves closed.

**RP.2 FUEL DEPARTMENT PERSONNEL ACTION**

If the leak cannot be immediately stopped or controlled, the following actions should occur immediately:

**RP.2.1 Underground Pumphouse Area**

- De-energize lower harbor tunnel.
- Close valves behind ventilation building outside Adit # 1.
- Open valve on lower diamond plate area in the UGPH to pump from sump to Tank B1.
- Make as much space in Upper Tank Farm (UTF), Surge Tanks 1 through 4, and interface Tank 301 as possible.
- Close sluice valve for the impoundment area outside of Adit # 1 (see Figure RP.1).
- Move Control Room operations to Building 1757.

**RP.2.2 Red Hill Area**

- De-energize sump pump at Adit #3, check outlet for fuel.
- Continue to pump from sump pumps in LAT near Tanks 1 and 2 (see Figure RP.2) to Tank 311 outside Adit # 3. There is no level gauge or high-level alarm for Tank 311.

- Dispatch an operator to verify the level of Tank 311 by manually gauging the tank. When high-level is reached, sump pumps will automatically stop. Verify this operation on AFHE.

**Figure RP.1: Location of Sluice Valve for Impoundment Area outside Adit # 1**

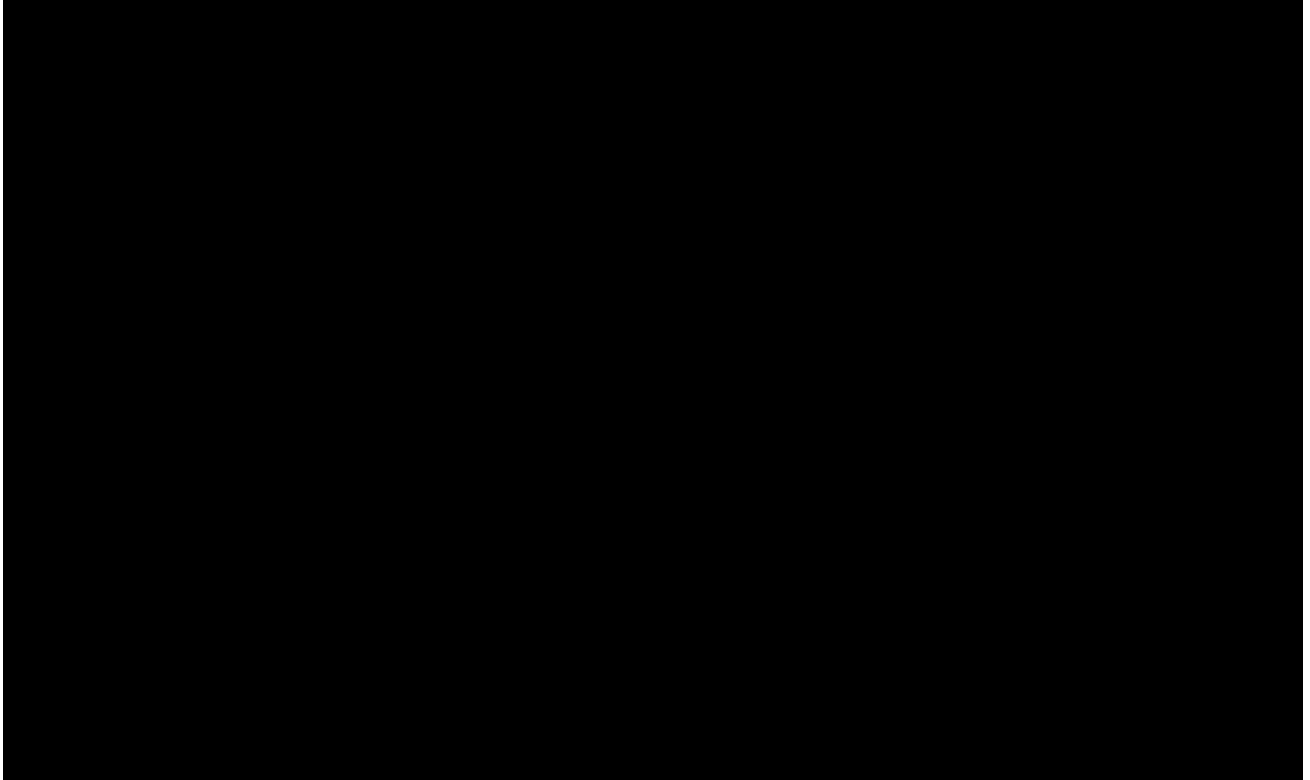

**Figure RP.2: Lower Access Tunnel Sump below Tanks 1 and 2**



**RP.2.3 Waste Oil Tanks B1 & B2**

- Monitor both Tanks B1 and B2 for fill level. If Tanks B1 and B2 are nearing 80% of allowable fill, take the next actions.
- Stop all pumping operations sending fuel up the hill. Make sure valves 232T2 and 232T1 are closed to limit line contamination.
- At the bottom of the back stairs of the UGPH underneath the grating, open [REDACTED] that Tees into [REDACTED], close valve to sump and open the sump discharge line to the [REDACTED]
- Line up F-76 to the inside loop and fill up all available F-76 ullage in the UTF and Surge Tanks 3 and 4. Fill past high-level alarms to high-high levels. Monitor tanks closely for overflow.
- If available, fill SWOB or YON barges at Hotel pier from UTF.
- Before last tank reaches high-high level, line up F-76 pipe to outside loops, open valve 0310G and valve 0310H, and start filling interface Tank 301.
- When Tank 301 fill level is high-high, close tank fill valve 0301H and open JP-5 valve 0310D, which will pressurize JP-5 outside loop. Open JP-5 outside loop to Surge Tank 1. Pump Surge Tank 1 to available JP-5 ullage at Red Hill. Fill tanks to high-high level as necessary.
- If more ullage is required, close valve 0310G and 0310H and fill Surge Tanks 3 and 4, if they are not full already. When they are full, de-energize sump pump and pump Surge Tanks 3 and 4 up the hill to diesel tankage.

**RP.3 EMERGENCY PHONE LISTS**

TABLE RP.1: NAVSUP FLCPH OIL SPILL RESPONSE TEAM				
Position	Day Phone	24 Hour Phone	Response Time	Response Job
Fuel Director	473-7833	690-0115	< 1 hour	Emergency Spill Coordinator
Deputy Fuel Director	473-7801	780-3703	< 1 hour	Alternate Emergency Spill Coordinator
Supervisory Distribution Facilities Specialist	473-7824	216-1341	< 1 hour	Operations Section Chief
Bulk Fuel Operations Supervisor	473-7805	479-1063	< 1 hour	Deputy Operations Section Chief
Command Duty Officer	216-1339	216-1339	< 1 hour	Liaison Officer

Note: If the spill size, complexity, or impact is beyond the capability of the Fuel Department to manage, the Emergency Spill Coordinator or the Commanding Officer can contact the Region Navy On-Scene Coordinator (473-4689 or 864-2463) to activate the Region Spill Management Team (SMT). The Region SMT will then establish other Incident Command System (ICS) functions, such as Wildlife Recovery and Rehabilitation Branch, Documentation Unit, Resource Unit, etc. Port Operations is the coordinator for the Facility Response Team (FRT) and can be reached by telephone at 474-6262 or Channel 69.

Tables RP-2 and RP-3 provide contact information for Navy Spill Emergency Response/Cleanup Teams and Navy SUPSALV/Spill Response Contractors, respectively.



<b>TABLE RP.2: CNRH SPILL EMERGENCY RESPONSE/CLEANUP TEAMS</b>				
<b>Name</b>	<b>Day Phone</b>	<b>24 Hour Phone</b>	<b>Response Time</b>	<b>Response Job</b>
Port Operations	474-6262 or Channel 69	472-6262	< 1 hour	On-water FRT
NAVFAC HI Emergency Service Desk	449-3100	449-3100	<1 hour	Clean-up / Disposal
Fuel Department Personnel as required	Recall Roster	Recall Roster	<1 hour	Land/Water FRT

<b>TABLE RP.3: NAVY SUPSALV/SPILL RESPONSE CONTRACTORS</b>				
<b>Name</b>	<b>Day Phone</b>	<b>Other Phone</b>	<b>Response Time</b>	<b>Capability</b>
Navy SUPSALV	202-781-1731 Ext. 2	202-781-3889 (after hrs.)	< 12 hours	On-water containment and recovery
Pacific Environmental Company (PENCO)	545-5195	524-2307 (fax)	< 12 hours	On-water containment and recovery, and on-land cleanup capabilities.
National Response Corporation (NRC) <sup>1</sup>	631-224-9141	631-224-9086 (fax)	< 12 hours	On-water containment and recovery, on-land cleanup capabilities, and dispersant coverage (including dispersant aircraft).

<sup>1</sup>The CNRH NOSC Rep can also access the services of the NRC by going through U.S. Navy SUPSALV.

#### **RP.4 SPILL INFORMATION LOG**

Pending initial emergency actions and notifications, complete the Spill Information Log in Appendix C.

THIS PAGE INTENTIONALLY LEFT BLANK.

## **1.0 INTRODUCTION**

### **1.1 Plan Purpose**

The Red Hill Fuel Storage Facility (RHFSF) Response Plan provides response information and procedures for responding to a major oil spill emergency at the RHFSF. Federal regulations require Facility Response Plans (FRPs) to address worst-case discharges that could occur from aboveground storage tank (ASTs) at fuel storage or production facilities (under Title 40, Code of Federal Regulations, Part 112.20 (40 CFR 112.20)). The Red Hill underground storage tanks (USTs) are field-constructed tanks, and as such are deferred from this and many Federal and State UST program requirements. However, due to the unique nature of the RHFSF, the worst-case discharge that could occur within the Commander Navy Region Hawaii (CNRH) area of responsibility (AOR) would be the release of the entire contents of one of the twenty USTs located within this facility. To be better prepared for this unlikely situation, this plan has been developed to assist in the planning and training required to respond to a major release at this facility.

### **1.2 Plan Organization**

This plan is organized into four basic sections:

#### The Red Plan

This section details the critical actions that Naval Supply Systems Command Fleet Logistics Center Pearl Harbor (NAVSUP FLCPH) fuel personnel must take in the event of a fuel leak emergency at the RHFSF.

#### The Main Plan

This section provides general information about the RHFSF and the surrounding environment. It summarizes information from existing plans and provides specific information about responding to a major fuel release at the facility. Information covered includes a description of the facility, facility history, fire and safety systems, leak detection system, environmental setting, environmentally sensitive areas, groundwater and hydrology, site safety information, response equipment resources, waste management and disposal procedures, evacuation procedures, and references.

#### The Scenario Tabs

These tabs outline two different scenarios, a worst-case discharge (WCD) and a maximum most probable discharge (MMPD), that could possibly occur at the RHFSF. Although highly unlikely due to continued upgrades to the facility, each tab describes the scenario and discusses immediate response actions; general response operations; response objectives; maps, diagrams and figures; and response equipment calculations (if applicable). These scenarios are used for planning and training purposes only.

#### Appendices

The appendices provide supporting information such as notification lists, information on financial responsibility, a spill information log, safety data sheets, a location system for the

facilities tunnels based on frame mark numbers, and a list of acronyms.

### **1.3 Plan References**

Several references were used in the development of this plan; see Section 13 for a complete list of references.

## 2.0 FACILITY INFORMATION

### 2.1 Facility Location

The RHFSF is located in a ridge of volcanic rock known as Red Hill on the western edge (leeward side) of the Koolau Mountains that divides South Halawa Valley and Moanalua Valley. It is approximately 2.5 miles northeast of Joint Base Pearl Harbor Hickam (JBPHH) (see Figure 2.1) and occupies approximately 144 acres of land surrounded by Federal, State, and residential property. The majority of the surface topography of the site lies at an elevation of approximately 200 to 500 feet above mean sea level. The Red Hill ridge extends southwesterly toward JBPHH and provides protective cover not only for the underground fuel storage facility, but also for the long tunnel that connects the fuel storage facility with the UGPH, Adit 1.

Figures 2.2 and 2.3 provide a topographic and three-dimensional view of the facility, respectively, with the RHFSF superimposed on both.

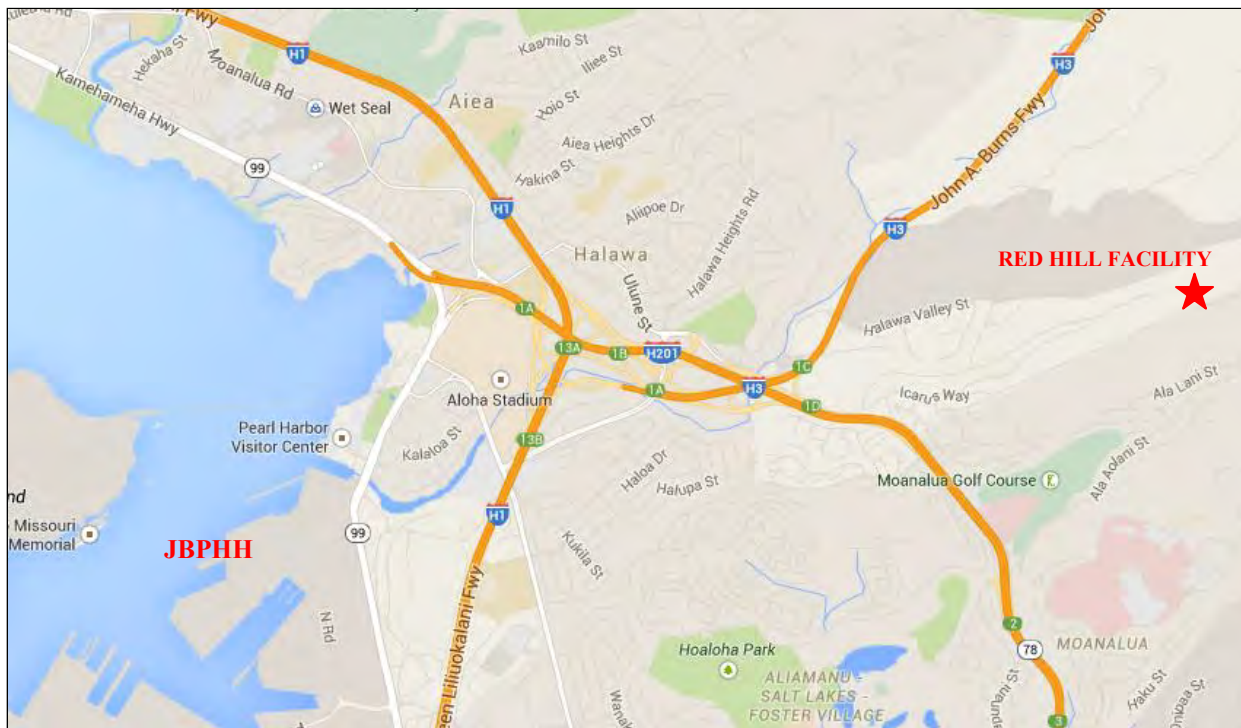

**Figure 2.1: RHFSF Location**

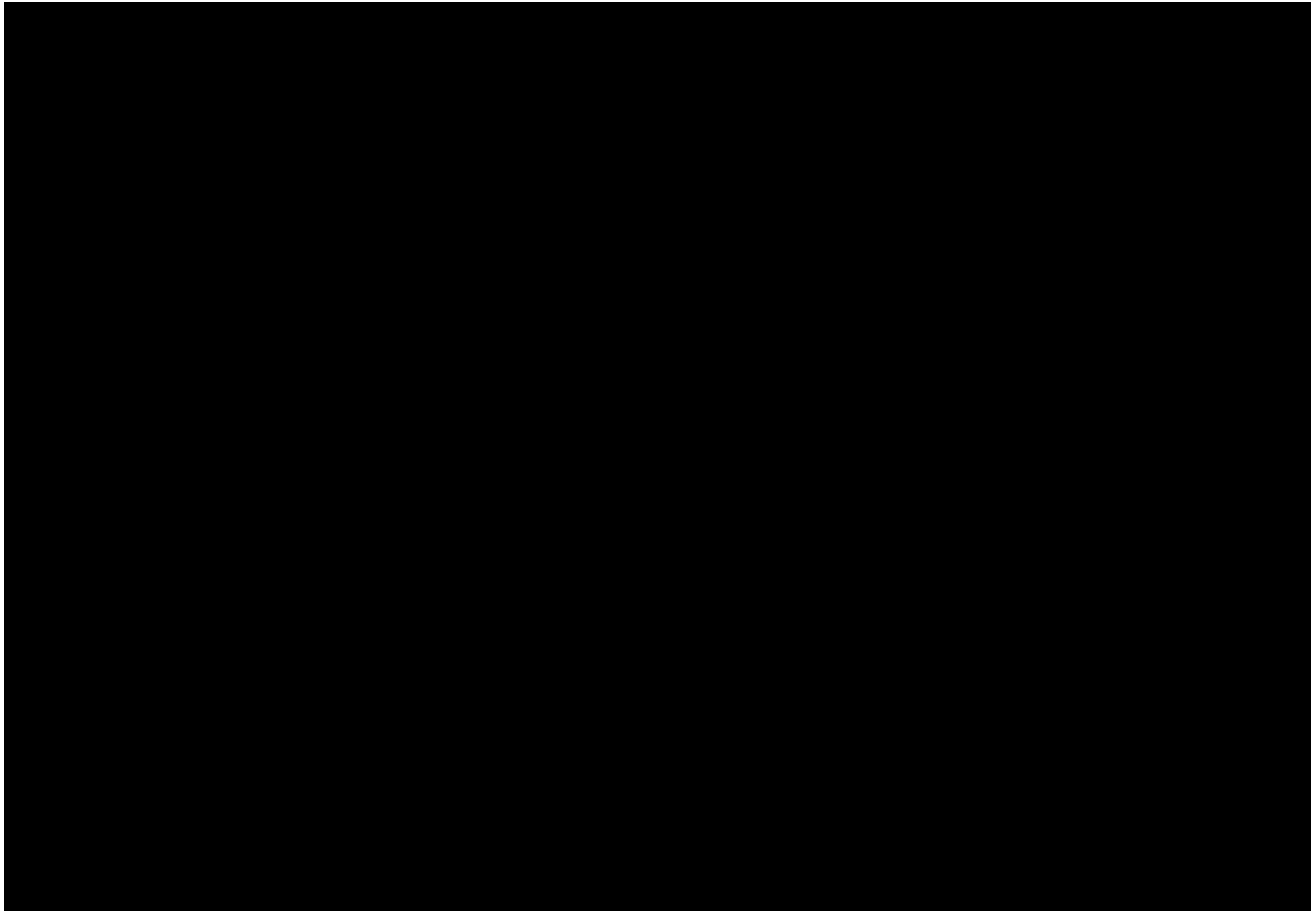

**Figure 2.2: Topographic View of the RHFSF**

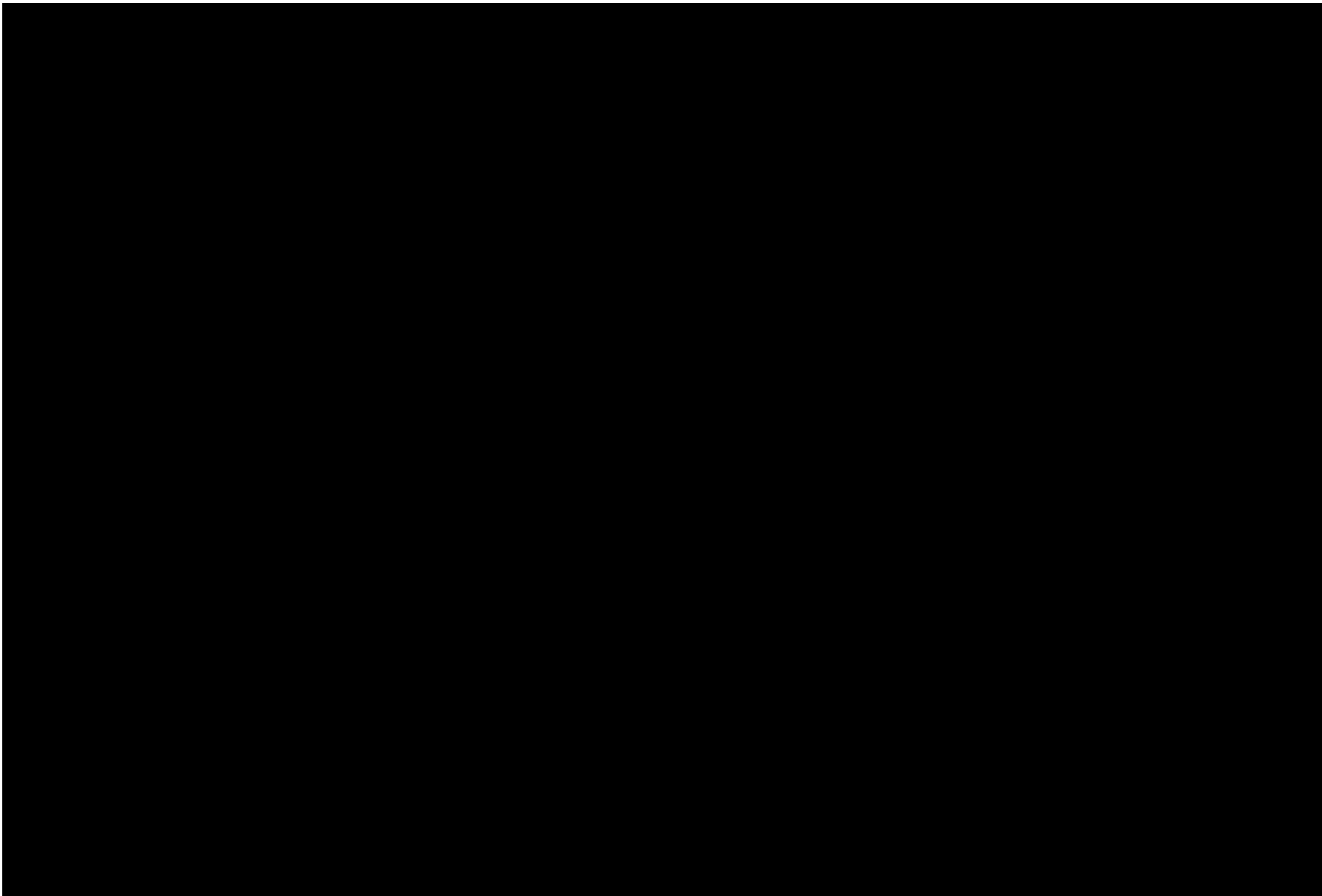

**Figure 2.3: Three-Dimensional View of the RHFSF**

## 2.2 Facility Description

The RHFSF consists of sixteen 302,000-barrel and four 285,500-barrel field-constructed USTs containing Jet Fuel Propellant No. 5 (JP-5), North Atlantic Treaty Organization - grade F-24 jet fuel (F-24), and Diesel Fuel - Marine Grade (DFM) (F-76). The tanks are constructed of reinforced concrete and lined with steel. The Primary containment material is steel. The tanks are located in subterranean vaults hollowed out of volcanic basaltic rock. Each tank has the form of a vertical cylinder, closed on top and bottom by hemispherical domes. The cylindrical portion of Tanks 1 through 4 has a height of 138 feet. The cylindrical portion of Tanks 5 through 20 has a height of 150 feet. The radius of the cylinder and domes is 50 feet, making the total height 238 (Tanks 1 through 4) and 250 feet (Tanks 5 through 20) and the diameter 100 feet (all tanks). The upper domes of the tanks lie at depths varying between approximately 110 feet and 175 feet below the existing ground surface. Table 2.1 provides details on the RHFSF storage tanks.

The twenty storage tanks at Red Hill are located 200 feet apart on centers in two straight rows running parallel with the ridge. Two tunnels, the UAT and the LAT, centered between the two rows of tanks provide access to the top and bottom of the tanks (see Figure 2.4). The UAT has its floor at the elevation of the spring lines of the upper domes of the tanks. The floor of the LAT is about 18 feet below the tank bottoms. Each of the tunnels has branches to the tanks, which are located opposite each other. Adits 4, 5, and 6 provide access to the UAT, and Adit 3 provides access to the LAT (see Figure 2.4). Bulkheads separate Tanks 17 through 20 from the remainder of the tanks in both the UAT and LAT. Both bulkheads have oil and fire proof doors for access through the bulkheads. Two elevators, one on each side of the bulkheads, are used for traveling between the UAT and LAT.

The LAT extends from Tank 20 approximately 17,000 feet down to the entrance of the UGPH at grades from 2% to 0.025%. A typical cross-section of the tunnel is approximately 12 feet wide by 10 feet high. The tunnel walls are lined with gunite (sprayed concrete). Three pipelines carry fuel from the storage tanks to the UGPH: a 16" pipeline carrying F-24; an 18" pipeline carrying JP-5; and a 32" pipeline carrying F-76. A narrow gauge train track runs the entire length of the LAT on which a battery-powered locomotive operates to haul personnel and supplies.

Approximately [REDACTED] from Tanks 1 and 2, down the [REDACTED]) is the entrance to Adit 3. This entrance provides the most direct access to the lower tank area of the fuel storage facility. At the junction of the [REDACTED]) resides [REDACTED]. This well provides approximately 24% of the potable water used by the JBPHH Water System. In this area, there is also a ventilation shaft for the tunnel. [REDACTED]. Adits 1 and 2 provide access to the LAT near JBPHH. [REDACTED]. [REDACTED]. [REDACTED]. Access to the COMPACFLT building is restricted by a steel door [REDACTED]. See Figure 2.4 for a schematic of the RHFSF.



There are [REDACTED] located in the [REDACTED] prevent an accidental release of fuel from flowing down unabated to JBPHH. These doors are normally [REDACTED] if fuel is released in the tunnel. They can also be closed remotely from the control rooms [REDACTED]. Door A is located in [REDACTED]. Door C is [REDACTED]. The third door is [REDACTED]. See Figure 2.4 for the locations of these doors. Two oil and fireproof doors are [REDACTED] from the remainder of the tanks. One other door, Door B, is a steel fire door [REDACTED]. There are also a number of other fire and ventilation doors located throughout the tunnels.

A newly installed “Emergency Oil Pressure Door” (see Section 4, Figure 4.1) at the end of the tank gallery in the LAT is designed to automatically close when oil is detected in its sump (via a high-level float indicating the sump is full) or a nearby push button is activated. Closing of the door activates the fire alarm system which sets off audible and visual alarms throughout the facility and alerts the Federal Fire Department (FFD). The door provides a fuel tight seal once closed and is designed to withhold the contents of one of the facility’s storage tanks.

TABLE 2.1: RHFSF TANK CAPACITY

Tank ID	Type	Material	Diameter (Ft)	Height (Ft)	Barrels	Gallons	Fuel Type	Year Built
<b>Red Hill Storage Tanks</b>								
1/0101	UST	RCLWS <sup>1</sup>	100	238	285,742	12,004,164	Empty	1943
2/0102	UST	RCLWS	100	238	285,387	11,986,254	F-24	1943
3/0103	UST	RCLWS	100	238	285,413	11,987,346	F-24	1943
4/0104	UST	RCLWS	100	238	285,246	11,980,332	F-24	1943
5/0105	UST	RCLWS	100	250	302,333	12,697,986	F-24	1943
6/0106	UST	RCLWS	100	250	302,286	12,696,012	F-24	1943
7/0107	UST	RCLWS	100	250	302,460	12,703,320	JP-5	1943
8/0108	UST	RCLWS	100	250	301,928	12,680,976	JP-5	1943
9/0109	UST	RCLWS	100	250	302,458	12,703,236	JP-5	1943
10/0110	UST	RCLWS	100	250	302,350	12,698,700	JP-5	1943
11/0111	UST	RCLWS	100	250	302,761	12,715,962	JP-5	1943
12/0112	UST	RCLWS	100	250	302,250	12,694,500	JP-5	1943
13/0113	UST	RCLWS	100	250	302,724	12,714,408	JP-5	1943
14/0114	UST	RCLWS	100	250	302,846	12,719,532	JP-5	1943
15/0115	UST	RCLWS	100	250	302,536	12,706,515	F-76	1943
16/0116	UST	RCLWS	100	250	302,450	12,702,900	F-76	1943
17/0117	UST	RCLWS	100	250	302,676	12,712,392	JP-5	1943
18/0118	UST	RCLWS	100	250	302,682	12,712,644	JP-5	1943
19/0119	UST	RCLWS	100	250	302,560	12,707,520	Empty	1943
20/0120	UST	RCLWS	100	250	302,498	12,704,916	JP-5	1943
FOR	AST	Steel	21	16	1,008	42,336	W. Oil	1970

TABLE 2.1: RHFSF TANK CAPACITY								
Tank ID	Type	Material	Diameter (Ft)	Height (Ft)	Barrels	Gallons	Fuel Type	Year Built
<b>Underground Pump House Surge Tanks</b>								
ST1/1224	UST	Steel	60	20	10,042	421,764	F-24	1942
ST2/1225	UST	Steel	60	20	10,050	422,100	JP-5	1942
ST3/1226	UST	Steel	60	20	10,064	422,688	F-76	1942
ST4/1227	UST	Steel	60	20	10,052	422,184	F-76	1942

**Note:** RCLWS<sup>1</sup> = Reinforced concrete lined with steel

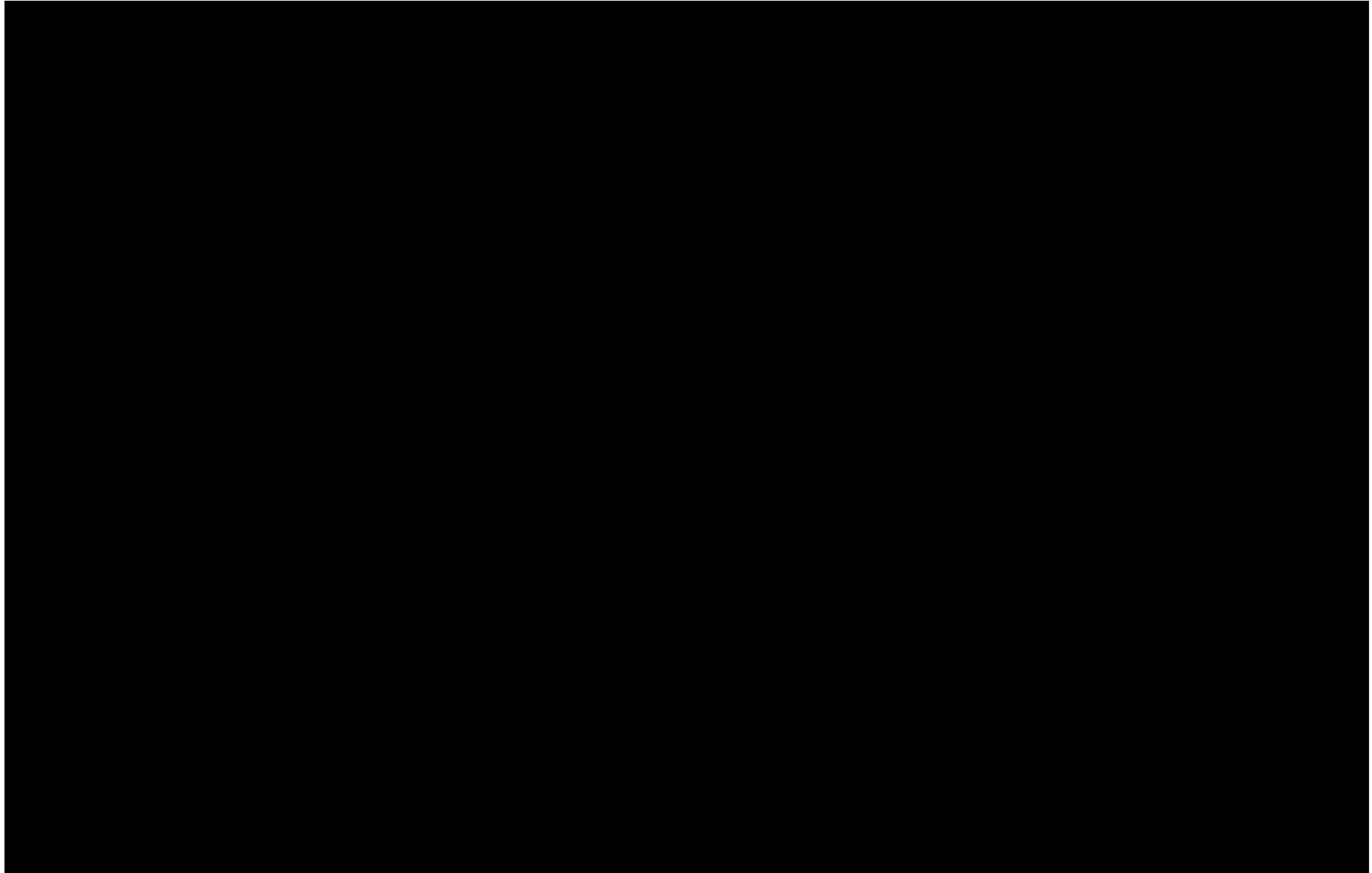

**Figure 2.4: RHFSF Schematic**

### **2.3 Underground Pumphouse**

The UGPH is used to transfer the receipt of fuel from Hotel Pier uphill into the Red Hill storage tanks. There are four underground surge tanks (each with a capacity of 10,000 barrels) located at the UGPH, along with associated pump, manifolds, and pipelines. These surge tanks help regulate the flow of fuel into the Red Hill tanks. Fuel is issued from the Red Hill tanks by gravity flow.

### **2.4 Red Hill Diesel Power Plant (Abandoned)**

The abandoned Red Hill diesel power plant is located off the LAT between the tanks and U.S. Navy Supply Well 2254-01. A narrow steel door in the LAT marks the location and former entrance to the diesel power plant, this steel door has been completely sealed. The power plant can also be accessed from the Red Hill Facility access road. This entrance is secured by a locked gate.

The power plant was used to provide the facility with electricity when it was first built. The plant was abandoned at an unknown date. Today the facility uses power from the public power grid, but also has backup generators for powering key equipment.

### **3.0 FACILITY HISTORY AND CONSTRUCTION**

#### **3.1 Initial Planning**

In a 1938 report, the Navy Shore Development Board at Pearl Harbor expressed a grave concern over the “adequacy and security of the fuel oil storage at Pearl Harbor.” At the time, the entire Navy’s fuel was stored in unprotected aboveground storage tanks at Pearl Harbor, next to the submarine base. The Board’s fears were later echoed by Admiral Chester Nimitz, Commander in Chief of the U.S. Pacific Fleet who was worried about the vulnerability of the Navy’s fuel storage tanks to the Japanese.

In the view of these vulnerabilities, the Navy’s Fuel Storage Board recommended to the Secretary of the Navy “that the present tank farms be removed as rapidly as appropriations can be obtained to place the oil underground at least to the point of concealment.” The board’s recommendation, which came on June 25, 1940, resulted in a plan to construct four 300,000-barrel capacity horizontal storage tanks. The tanks were to be set deep into the earth so that they would be impregnable to assault by enemy aircraft and located at a greater distance from Pearl Harbor. The plan also called for the construction of facilities to unload tankers and refuel ships.

Initial design and construction funds of \$4,000,000 were provided for the classified project known as “Project 16.” An additional \$2,250,000 was appropriated in September 1940.

#### **3.2 Facility Design**

Regarding the facilities design, the Navy was adamant that the fuel be stored underground; other than that stipulation, the on-site engineers were given a free hand in determining the optimal design of the tanks. The initial design that the engineers came up with was to dig a series of tunnels and insert the tanks inside of them. Finding a suitable site proved problematic as the area around Pearl Harbor was underlain by volcanic rock that was full of cavities, cracks, holes, and bubbles. Navy engineers finally settled on Red Hill, about 2.5 miles northeast of Pearl Harbor, as it was mostly homogeneous basalt.

At the time, Red Hill was not owned by the Navy and was under cultivation for sugar cane and pineapple by local plantations, most of it owned by the Damon Estate. The Navy initially leased the land from the plantations, cleared and leveled it, and then began construction of temporary work camps. Eventually the plantation owners were forced to sell out to the Navy through direct condemnation. The Navy purchased 345 acres in the area at an average price of \$242 per acre.

As planning progressed, a consultant engineer named James P. Growden, of the Aluminum Company of America, was brought in to review the plans for the project. He came up with an alternate plan for building the storage tanks. Instead of inserting tanks horizontally in underground tunnels, he suggested excavating large vertical tank chambers. The benefit of this design would be that it would increase the volume of material that could be excavated simultaneously and decrease the amount of heavy equipment needed for hauling muck. It would also decrease the unit cost for rock removal substantially.

### 3.3 Construction

Initial construction began August 19, 1940. To determine the depth necessary to protect the fuel from Japanese aerial attack, the engineers gathered data from the Army, multiplied it four-fold and rounded the figure off to 100 feet of rock cover. The tanks were to be set up in two parallel rows with two main access tunnels, one above the other, bisecting the rows (see Figure 3.1). Smaller tunnels, or adits, would branch from the main axis tunnels to the tank cavities.

#### Access Tunnels

Once the tank invert level and radius of curvature were determined the digging of the access tunnels commenced. Both the upper and lower access tunnels were excavated simultaneously (see Figure 3.2). They were constructed like the horseshoe shape of railroad tunnels, flat floors and walls, with an arching ceiling. The tunnels were roughhewn and lined with gunite (sprayed concrete) for increased strength.

#### Chamber Adits

As the main access tunnels moved past the location of a proposed storage tank, workers began digging the branch lines, or horizontal adits. The adits were smaller, man sized, and were shored with steel H-beams bolted together and sprayed with cement. The lower adit was excavated as far as the center point of the tank and the upper adits were stopped when they reached the outer radius of the proposed tank.

#### Tank Chamber Excavation

In the upper adit, once the outer radius of the tank had been reached, a ring tunnel was dug around the circumference of the tank chamber. Upon completing the ring tunnel, the miners dug upwards in a hemisphere from all points around the ring, narrowing as they reached the central shaft. Meanwhile, a vertical 12-foot by 12-foot shaft was excavated from the ridgeline through the central axis of the chamber, down to the lower adit (see Figure 3.3). Over 3,000 tons of dynamite was used in excavating the tank vaults and tunnels before blasting operations were completed.

#### Construction of Upper Tank Domes

Each section of the dome had to be braced with timber, prefabricated above ground in the exact curvature of the dome. This allowed the miners to dig to a template reducing time of excavation. I-beams were sent down and assembled to form ribs around the dome. Sections of steel plates cut so that they could be pieced together to form the dome were sent down and welded together. The wood shoring had to be shortened and replaced to account for the H-beam steel sets and liner plates. A pipe network extending down the central shaft and radiating around the dome was constructed for pouring concrete that would line the tank chambers. Each chamber dome required 70 hours of continuous pouring for 5,000 cubic yards of concrete.

#### Tank Excavation

As soon as the upper hemisphere concrete had set, workers were lowered down the central shaft to begin excavation of the tank chamber. The miners dug outwards in all directions under the dome, keeping a 30 to 45 degree slope to the center of the shaft, so muck would slide into the

shaft by gravity; greatly reducing labor and transport for the project (see Figure 3.4). At the bottom of the vertical shaft, rock screens (grizzlies) broke up falling rock so it could be transported on conveyors. In the lower adits, an elaborate conveyor belt system was constructed to carry mucked rock one half mile to the surface where it was processed through the crushing plant and batching plant and then sent back into the hill as concrete. The central tank shafts were expanded in a cone under the upper dome until the desired diameter was reached. The miners continued to dig downwards in a cone until they reached the lower hemisphere of the tank chamber. The lining for the lower hemisphere was placed similarly to the top (see Figure 3.5). Any cracks or holes found during excavation were grouted and sealed.

### Constructing the Tank Liners

After excavation, the rock walls were gunited, the specification calling for a minimum thickness of 6 inches and a maximum thickness of 1 foot 6 inches. The gunite surface was coated with asphalt and painted with a red earth slurry. Rings of steel ribs were sent into the tank from the shaft above and assembled in the tank to form the skeleton onto which one-quarter inch steel plates were welded to form the tank's inside liner. Concrete was poured into the space between the tank liner and the gunited rock wall. Once the concrete had set, high-pressure grout was injected into the tension cracks and spaces remaining between the concrete and the tank liner (see Figures 3.6, 3.7, and 3.8). The concrete backing varied in thickness from 8 feet at the spring line of the lower dome to two and a half feet at the top of the cylindrical wall. The lower dome of the tank rested on a huge plug of concrete almost 20 feet thick.

### Testing the Tanks and Fixing Leaks

Once each tank was completed, it was given a leak test. The tanks were filled with water and if there was more than a ½ inch drop in 24 hours, the tank failed the test. In order to locate the leaks, the tanks were filled very slowly with water, as high-pressure air was injected outside the tank. Welders in boats on the slowly rising pool of water would look for the bubbles of air entering the tank's steel lining, once found they would signal for the water level to be lowered and then weld the leaking seam. When each tank was complete, the top was closed and the access shafts above the tank chambers were filled with concrete.

### Completed Project

As the work progressed the number of tanks was increased to fifteen and finally to twenty. As part of the same project, the fuel pier (Hotel Pier) at Pearl Harbor was built and miscellaneous items, such as roads, tunnels, pumps, and emergency work were added until the completed work amounted to more than \$42,000,000. Work on the project was completed on September 30, 1943.

The number of men on the project reached a peak of 3,400 in June 1942 and remained at that level until October of 1942 when the first two tanks were completed and turned over to the Navy for operation. By February 1943, the Navy had assumed operation of ten completed tanks. The remaining ten tanks were completed by July 1943.

### 3.4 Quantities Involved in Building the Red Hill Tanks

*Excavation, cubic yards:* 1,690,000  
*Timber, foot board measure:* 4,618,000  
*Tunnel steel supports, pounds:* 1,000,000  
*Grout, sacks of cement:* 1,200,000  
*Reinforcing steel, pounds:* 21,000,000  
*Wire Mesh, square feet:* 687,000  
*Gunite, sacks cement:* 578,000  
*Concrete, cubic yards:* 413,000  
*Structural steel, pounds:* 4,000,000  
*Shaft excavation, cubic yards:* 50,000  
*Steel liner plate, 1/4 inch:* 45 acres (20,000,000 pounds)

### 3.5 Quick Facts on Red Hill

*Location:* Ridgeline between South Halawa Valley and Moanalua Valley  
*Construction started:* August 19, 1940  
*Construction completed:* September 30, 1943  
*Total construction time:* 2 years, 9 months  
*Cost of construction:* \$43,000,000  
*Primary contractor:* Morrison Knudsen  
*Amount of worker on project:* 3,400 (peak)  
*Fatalities:* 17 workers  
*Number of tanks:* 20  
*Capacity of tanks:* 16 at 302,000 bbls (12.7 million gals); 4 at 285,500 bbls (11.9 million gals)  
*Capacity of all 20 tanks:* 5,974,000 bbls (251 million gals)  
*Tank Height:* 16 at 250 feet; 4 at 238 feet  
*Tank Diameter:* 100 feet  
*Depth of tank tops below surface:* 110 to 175 feet  
*Depth of tank bottoms below surface:* 360 to 425 feet  
*Deepest point:* Lower tunnel beneath Tanks 19 & 20 (approximately 450 feet)  
*Length of upper tunnel:* Approximately 4,350 feet  
*Length of lower tunnel:* Approximately 17,000 feet  
*First oil received:* Diesel in Tank 1 on September 28, 1942 from tanker SS Fairbanks  
*First issue to ship:* Diesel to submarine USS Tarpon in October 27, 1942  
*Facility declassified:* 1995



**Figure 3.1: Red Hill Design Concept**

Figure 3.1 is a sketch of the original design concept for the vertically arrayed storage tanks. At the time, nothing like this had ever been attempted previously, where the contractor would use gravity to “flow” rock muck to the base of each cavity where it would be removed by a conveyer system.

**Figure 3.2: Side Hill Entrance to Tank Excavations**

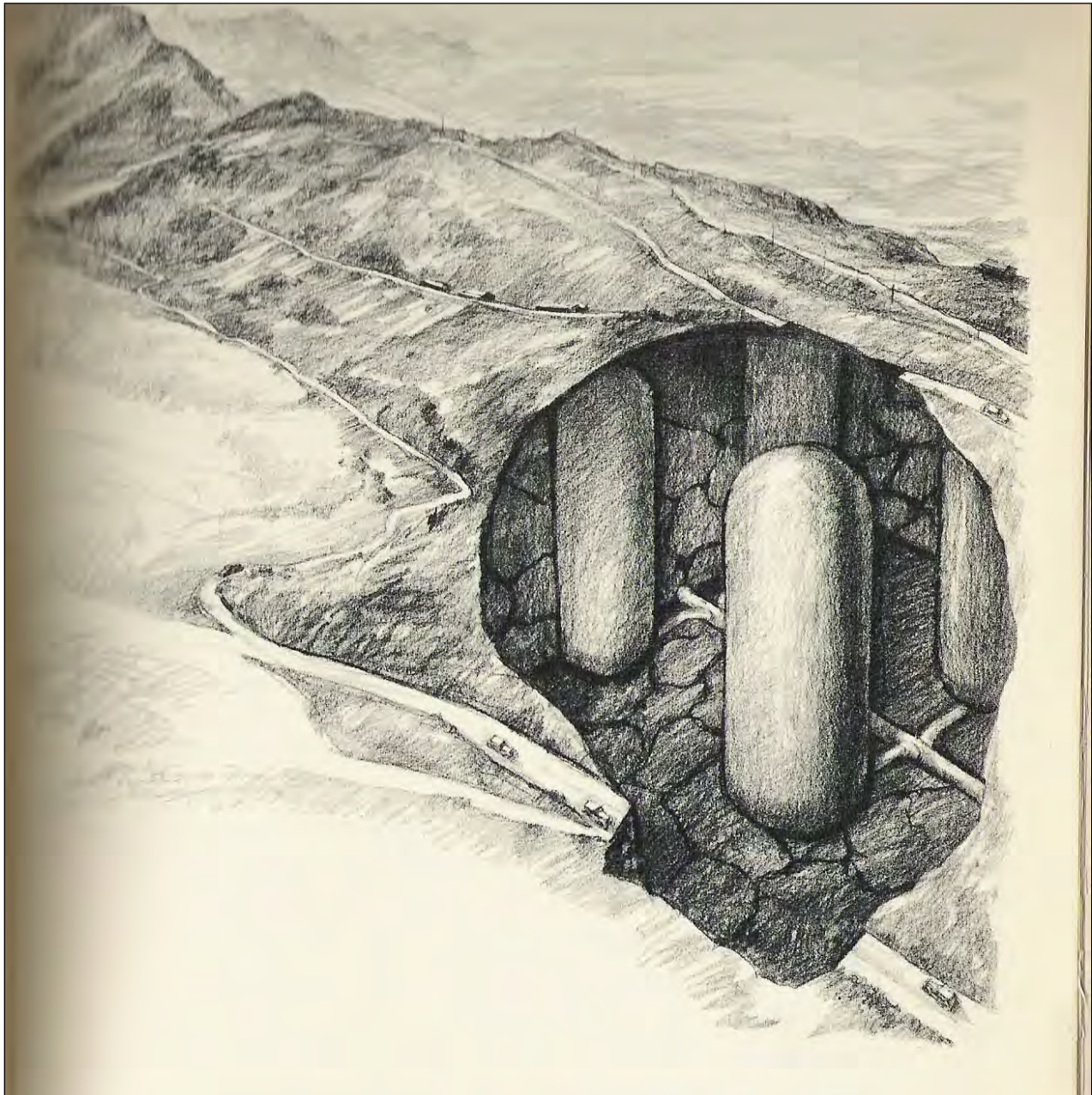

Figure 3.2 is a sketch of the side hill entrance to the tank excavations and lower access tunnel.

Figure 3.3: Chamber Excavation Schematic

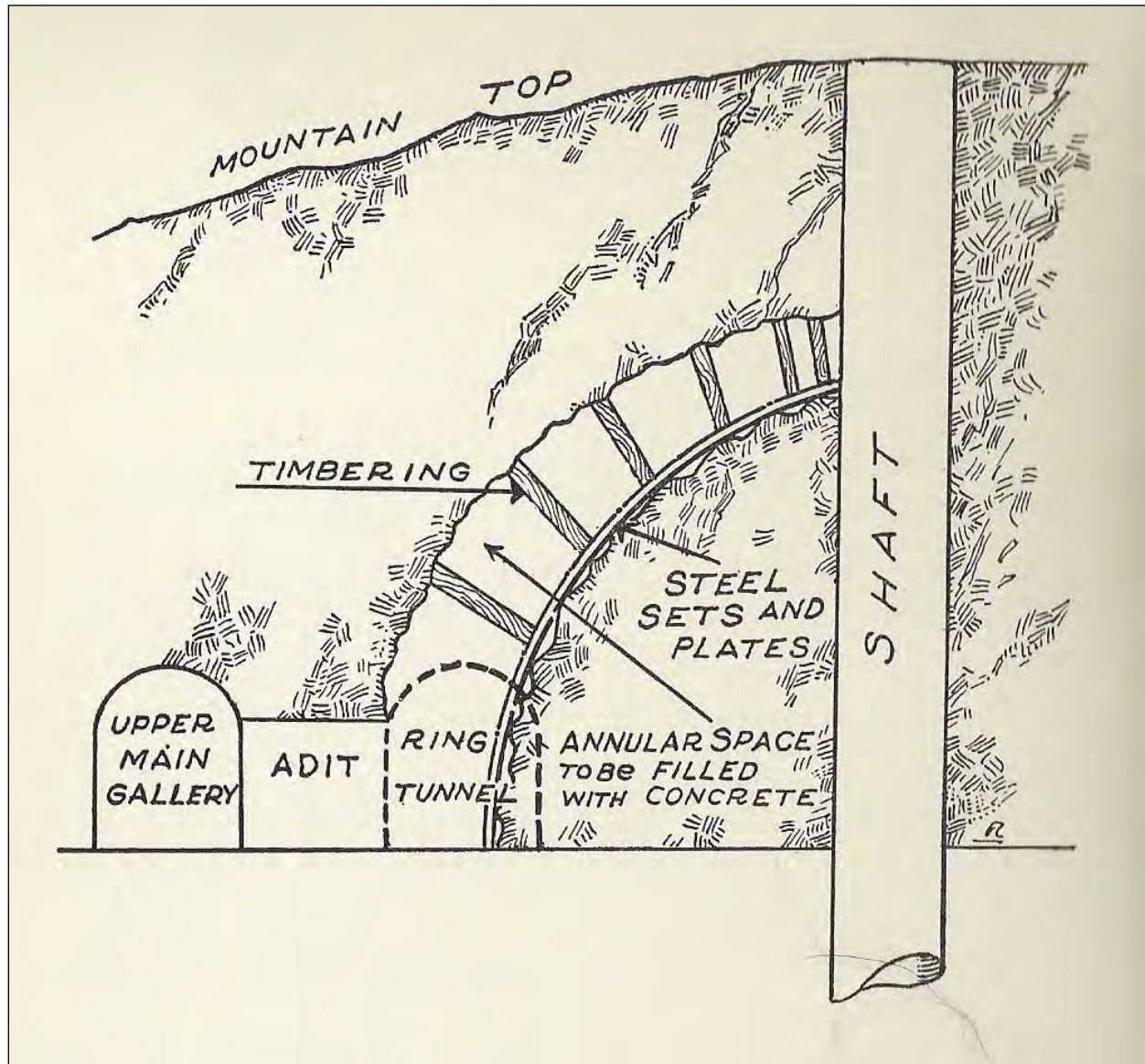

Figure 3.3 displays how each chamber excavation began. The upper dome of each chamber fuel chamber was excavated first, starting with a ring tunnel, and then working upward towards the central shaft.

**Figure 3.4: Tank Excavation Process**

Figure 3.4 displays how the tanks were excavated. After the upper hemisphere dome was concreted, miners began mucking the upper tank chamber, dropping muck by gravity through the central shaft.

**Figure 3.5: Lower Tank Dome under Construction**

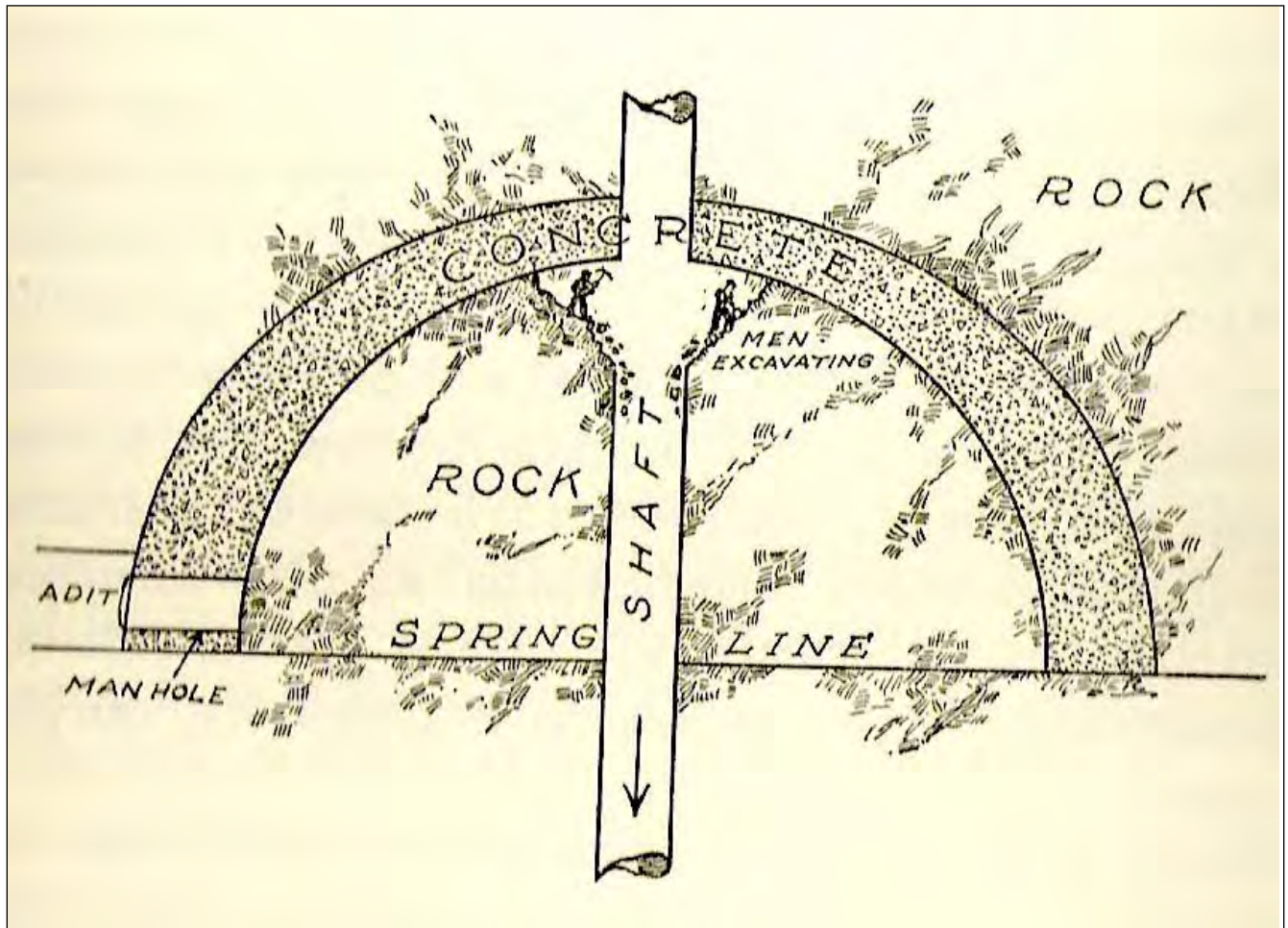
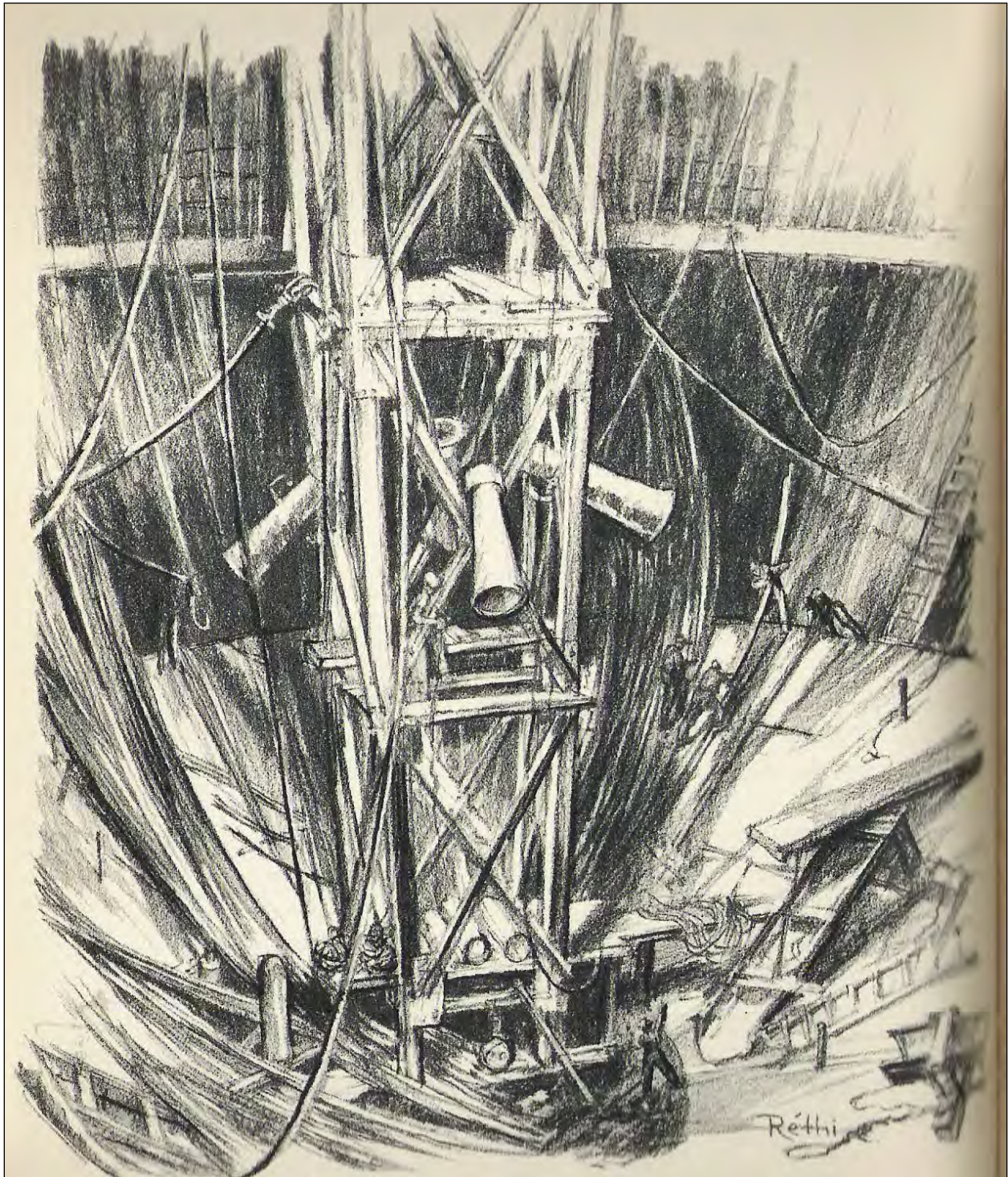

Figure 3.5 shows a sketch of a tank's lower hemisphere under construction and being lined with concrete with an inner steel lining.

**Figure 3.6: Construction of Tank Walls**

Figure 3.6 shows a picture of workers constructing the tank walls. The picture shows the guniting (concrete spray), asphalt, and red earth slurry being applied to the rock face near the bottom of a chamber.

**Figure 3.7: Lining the Walls of the Tank Chamber**

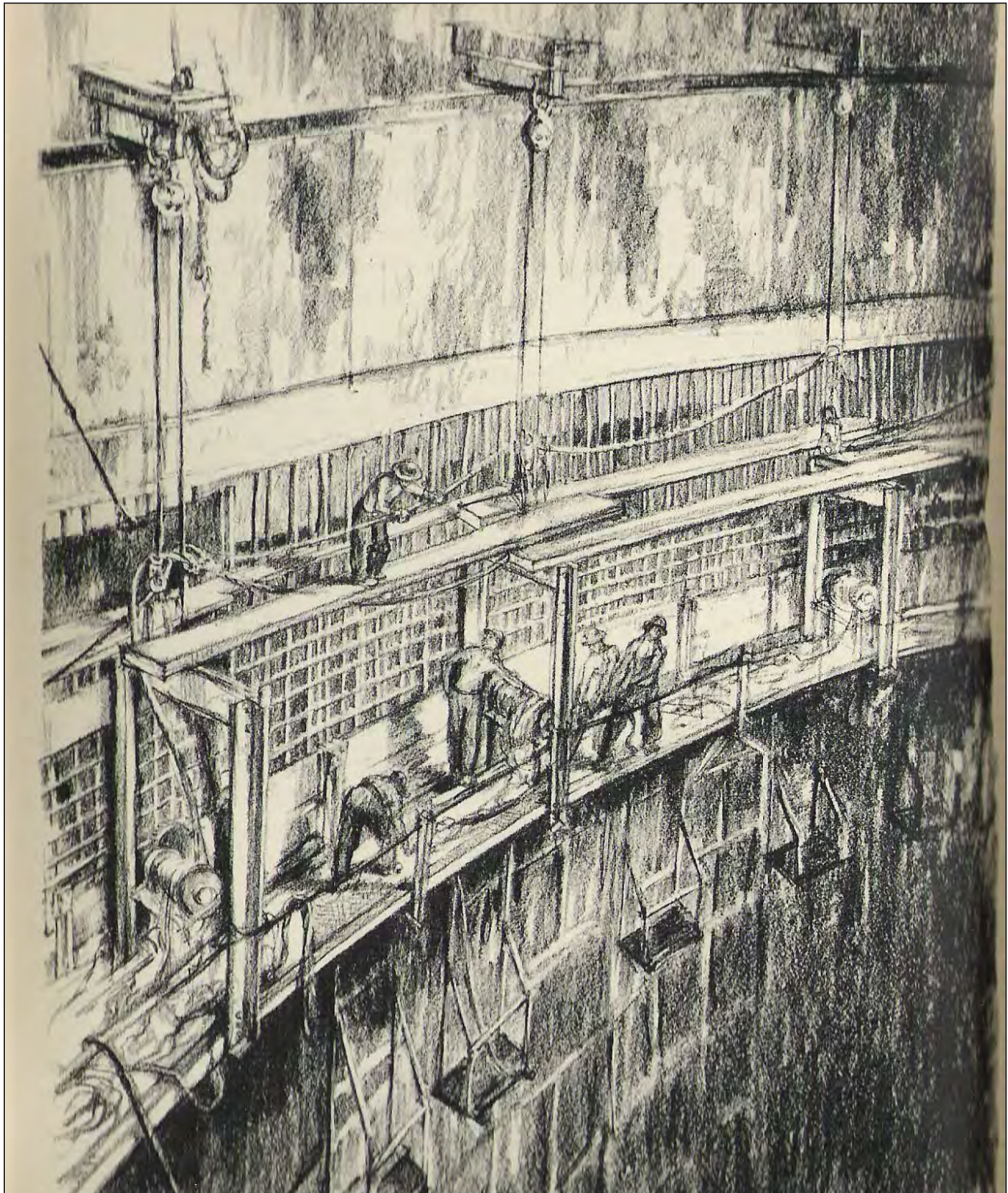
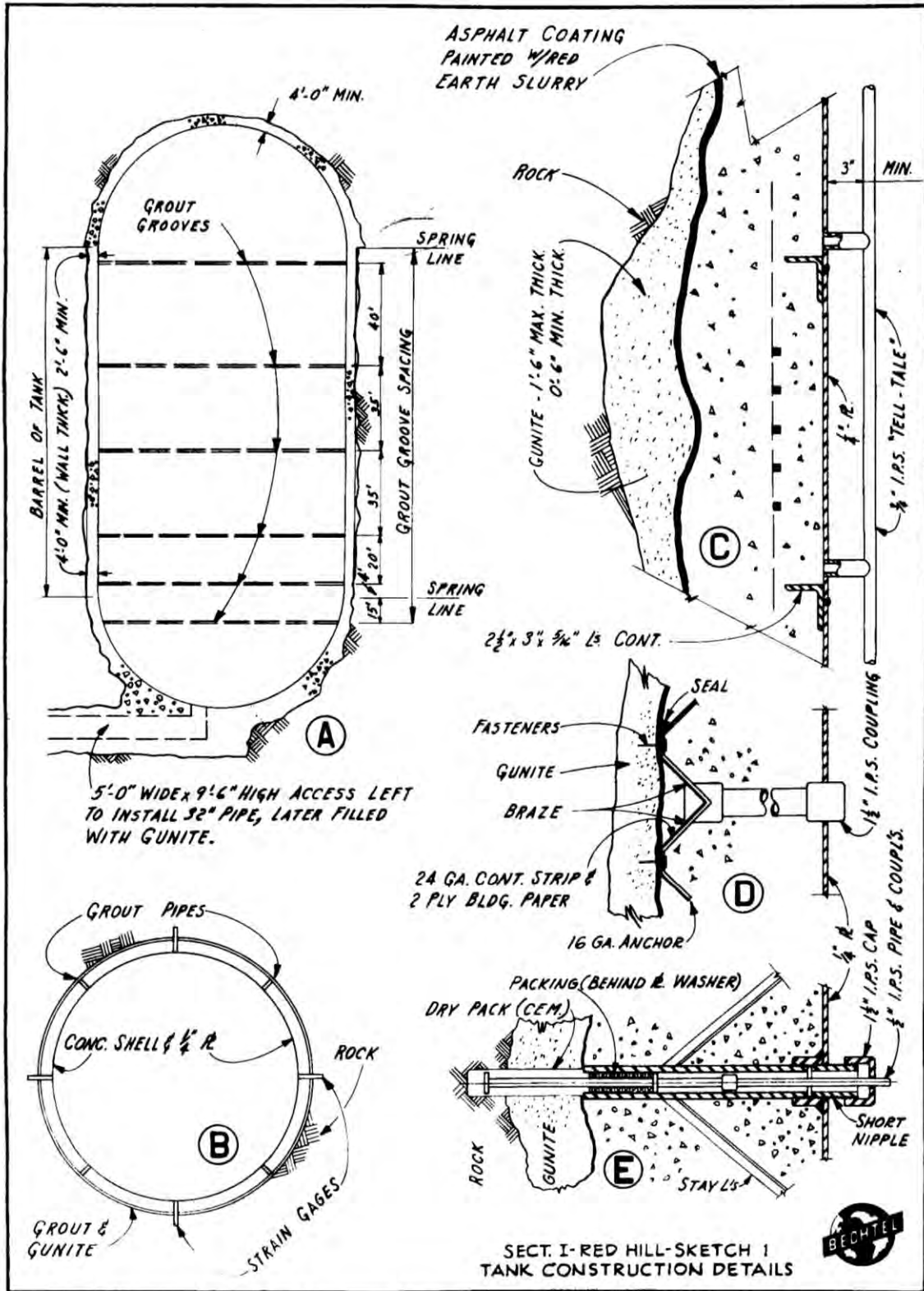

Figure 3.7 is a sketch showing workers lining the walls of the tank chamber. Reinforced concrete was placed against the rock and smoothed continuously; welded steel plate formed the inner liner.

Figure 3.8: Tank Construction Details





### 3.4 References

Bechtel Corporation, 1949, *Engineering Survey of U.S. Navy Petroleum Facilities at Pearl Harbor*, May 1949, 181 pp.

Center Relay, 2009, *The Underground*, Center Relay Special Edition, March 2009, 12 pp.

Rogers, J. D., (Date Unknown), *Red Hill Storage Tanks* (pdf), retrieved from <http://web.mst.edu/~rogers/umrcourses/ge342/Red%20Hill%20Storage%20Tanks-revised.pdf>

Woodbury D., 1946, *Builders for Battle: How the Pacific Naval Air Bases Were Constructed*, Dutton and Company Inc., 1946, 225 pp.

THIS PAGE INTENTIONALLY LEFT BLANK.

## **4.0 FACILITY FIRE AND SAFETY SYSTEMS**

### **4.1 Introduction**

During the period 2015 through 2019, many safety improvements were made to the RHFSF including a new fire protection system. This section provides a summary of the fire and safety improvements made to the facility during this period.

### **4.2 Fire Alarm System**

#### **4.2.1 Overview**

The fire alarm system is a Class A Detection and Mass Notification system that span's the entire facility. The system works with and controls the previously installed fire protection systems located at the UGPH and Buildings 1721 and 1613, which are commonly referred to collectively as the "Cheetha" system. The new system can be controlled from two locations, the UGPH and the Lower Tank Gallery Gauger Station. From these two locations, operators can seek/provide systems checks, updates, alarm logging, mass notifications, and system deactivations. The system consists of the following:

- Fourteen Addressable Nodes that operate initiating devices, notification devices, and auxiliary functions.
- Forty Audio Nodes that control all speakers.
- Five Network Graphic Annunciators (NGAs) that allows user to view events/alarms and acknowledge, silence, and reset the system.
- Six Microphones that allow the operator to make an announcement through a manual page or a prerecorded message.
- Nine Network Stations (NWSs) used for system monitoring and checking of current inputs/alarms. NWSs are located at the entrance to each adit.
- Two King Fisher Panels for monitoring the system and transmitting alarm, supervisory, and trouble event to the Regional Dispatch Center, who dispatches the FFD upon receiving an alarm event.
- One Federal Signal mass notification interface that allows base-side messaging over all speakers.
- Two Direct Digital Control (DDC) interfaces to the fire alarm system that monitors components on the fire protection system.

#### **4.2.2 Description**

This section provides a description of the fire protection system.

- The Fire Pumphouse located outside of Adit 6 provides water for the following:
  - A closed head sprinkler system in the UAT
  - Fire department connection (FDC) points in the UAT
  - An aqueous film forming foam (AFFF) closed head sprinkler system in the LAT
  - FDC points in the Tank Gallery of the LAT
- The fire alarm system monitors the equipment inside of the pumphouse that includes fire pumps, jockey pumps, foam pumps, foam jockey pumps, N2 generator, and all valves. Two 250,000-gallon water tanks on top of the ridge above Adit 6 provide water to the pumphouse.

- The UAT (Upper Tank Gallery) is fully monitored by heat detectors and a closed head sprinkler system. This system once activated will start fire pumps in the Fire Pumphouse while also communicating to the FFD through the King Fisher system.
- The LAT (Lower Tank Gallery) is fully monitored by explosion proof heat detectors (Tank 1 to Adit 3), ultra-violet infrared (UVIRs) detectors (Tank 1 through Tank 20), supervised valves (AFFF Foam Closets 1 through 5), and pressure switches (AFFF Closets 1 through 5) which are used in concert to activate the AFFF closed head sprinkler system. This system once activated will start fire pumps and foam pumps in the Fire Pumphouse while also communicating to the FFD through the King Fisher system. Note: the AFFF system once activated can only be suspended at either the UGPH or Gauger Station. Suspension will not stop water flow, but will close releasing solenoids for AFFF concentrate.
- The Harbor Tunnel is fully monitored by explosion-proof heat detectors, however fire suppression is not provided beyond Tanks 1 and 2.
- The UGPH is the overlap section of the existing FM-200/AFFF systems (Cheetah system) with the new fire alarm system. While both heat detectors and UVIR detectors were installed in the UGPH as part of the recent fire system upgrades these are not the releasing devices for either of these systems. In the main pump room, the original 3 infrared (IR) detectors (tied directly to the Cheetah system) are the release devices for the AFFF in the main pump room. Additionally, in the UGPH Control Room and main 12KV transformer room, the original heat detectors (tied to the Cheetah panel) must be tripped for the FM-200 or the AFFF to be released.

### 4.2.3 Activation

This section discusses how the fire protection system is activated.

- The Fire Pumphouse consists of manual pull stations, thermal heat detectors, and smoke detectors. If one of these devices is tripped, audible and visual alarms activate in the Fire Pumphouse, and the FFD is notified of the alarm.
- The Upper Tunnel and Adit 6 consists of manual pull stations, thermal heat detectors, smoke detectors, and UVIRs detectors. If one of these devices is tripped, audible and visual alarms activate throughout the facility, with the exception of the Fire Pumphouse, and the FFD is notified of the alarm.
- The Lower Tunnel consists of manual pull stations, thermal heat detectors, smoke detectors, and UVIRs detectors. If one of these devices is tripped, audible and visual alarms activate throughout the facility, with the exception of the Fire Pump House, and the FFD is notified of the alarm. If two (2) UVIRs are tripped, or one (1) UVIR and one (1) Nitrogen Low Pressure Switch is activated within the same zone, the AFFF pumps will start, releasing AFFF into the zone. Note: Currently the AFFF system is inactive. Activation of the sprinkler system will release water only.
- For the UGPH the FM-200 system and the Deluge/AFFF system are both controlled by the Cheetah panel located in the UGPH Control Room. Additionally, both systems communicate with FFD from the King Fisher panels located in the front of Adit 1 and in Building 1613. The sequences for activating the FM-200 system is that two (2) existing smoke/heat detectors located in the UGPH Control Room or in the main electrical switchgear room must be activated. Once this occurs the Cheetah system will send the release command to either FM-200 system depending on which area is affected. Additionally, located directly inside of the UGPH Control Room are two emergency release buttons/abort buttons. The first set located

at the corridor entrance to the control room will enable/abort FM-200 in the main fuel control/monitoring room. The second set located at the door between control room and the main switchgear room beyond will work in the same fashion. Should this system be tripped, it will also disable all fueling operations by shutting down pumps and closing valves under the main pump room floor. The sequence for the AFFF release is that two 3IR's (original ones) in the main pump room be activated to release the AFFF foam stored in Building 1613 (located atop Adit 1). The system is an open head deluge system and will flood the entire room.

### **4.3 Emergency Oil Pressure Door**

#### **4.3.1 Description**

The new Emergency Oil Pressure Door (OPD), see Figure 4.1, is located just down the LAT past Tanks 1 and 2, and is designed to contain the contents of one of the Red Hill tanks within the Tank Gallery of the LAT. The components of the OPD consist of a Scissor Lift, Maglock, Door, High Level Float and a Push Button on either side of the door. These components are described below:

- The Scissor Lift is an electrically powered hydraulic lift that lowers the platform and attached tracks, allowing the door to close. Upon activation of the Scissor Lift, the hydraulic cylinders raise the platform, retract the legs, and lower the platform to below the door threshold. On loss of power, the Scissor Lift will remain in its current state.
- The Maglock is an electro-magnetic lock that holds the door open until receiving an activation signal. On loss of power, the Maglock fails in the hold position, keeping the door from closing automatically.
- The Door is a reinforced steel door that closes automatically when the Maglock is released, creating a fuel tight seal.
- The High Level Float is located in the lift sump, and indicates when the sump is full. When the float is activated, a signal is sent to the DDC and Fire Alarm System, activating the OPD and notifying FFD of the event.
- The Push Buttons are wall mounted on side of the OPD, allowing the user to activate the OPD manually.

#### **4.3.2 Activation**

The OPD is activated by pushing one of the manual push buttons or receiving a high level alarm in the OPD sump. The sequence of events is as follows:

- Button is pushed/high level alarm activated
- Signal sent to DDC to begin OPD operations, simultaneously sending a signal to the Fire Alarm System.
- When the signal is received at the fire alarm system, audible and visual alarms activate throughout the facility (with the exception of the Fire Pumphouse) and the FFD is notified of the alarm.
- The DDC will send a signal to the Scissor Lift, starting the lift operations by raising the lift, retracting the legs, and lowering the lift to below the door threshold.
- Once the "lift lowered" signal is received, the Maglock will release, and the Door will automatically close, creating a fuel-tight seal at the OPD.



Figure 4.1: Emergency Oil Pressure Door

#### 4.4 Facility Access

[REDACTED]

[REDACTED]

## **5.0 LEAK DETECTION**

### **5.1 Past Leak Detection Methods**

At the completion of the tanks in the early 1940's leak detection was done using two methods. The first was by conducting hand outage gauging of the tanks. The results were converted to an innage value (fuel level), and the gross volume was determined from the tank strapping tables. The results were then compared to previous static readings for discrepancies.

The second method was by monitoring a configuration of "telltale" piping for evidence of fuel in areas outside the tank walls, between the steel plates and the concrete lining attached to the surrounding rock formation. When functioning properly, the telltale system provided a means of detecting a tank leak in a circumferential segment of the steel lining. The exact location of the leak would be determined by measuring the leakage at several different head pressures and extrapolating to zero rate on a graph of rate versus head. Air would then be introduced behind the steel lining in the suspected area and seams would be tested. The faulty steel lining seam would then be rewelded as necessary.

Over the years, the telltale pipes began to deteriorate and became clogged with fuel residue and other materials picked up between the tank's steel plates and the concrete lining. The system was eventually abandoned as it was determined that it was a major cause of some of the releases. The Asteroid Corporation eventually removed the "telltale" piping from all of the tanks in the 1980's during a cleaning and repair project.

### **5.2 Current Leak Detection Systems**

Currently, NAVSUP FLCPH Fuel Department employs two methods of leak detection: (1) ATG/AFHE and (2) Annual Tank Tightness Testing. In addition, groundwater monitoring and soil vapor monitoring are conducted, but are not considered leak detection system; see Section 8.5 for further details on the Red Hill groundwater-monitoring program.

#### **5.2.1 ATG/AFHE**

ATGs on each of the Red Hill Facility tanks are calibrated at least once per year to an accuracy of 3/16 of an inch. The Navy also verifies ATG measurements after each fuel movement by manually gauging the tanks with a tape measure calibrated annually by the National Institute of Standards and Technology. Any discrepancies between the ATG measurements and manual gauging greater than 3/16 of an inch are investigated to identify potential leaks. In addition, the Navy attempts to detect any UFM's, including leaks, from their UST system by collecting and processing ATG data using the AFHE System. Space and Naval Warfare Systems Command (SPAWAR) administers the AFHE system, and control room operators receive alerts of any potential UFM's. AFHE accounts for volumes that move through the UST system using flow meters, and ATG data combined with strapping charts. Under static conditions (no fuel transfers), AFHE generates a warning alarm any time there is an apparent net loss or gain of more than 1/2 of an inch of fuel in one of the tanks, and a critical alarm for more than 3/4 of an inches. During scheduled fuel transfers, AFHE generates a warning alarm for more than 1 inch, and a critical alarm for more than 1 and 1/2 inches.

The Navy investigates all UFM alarms and documents the results of the investigation in a UFM report. The Navy also conducts a visual trend analysis of ATG data using Excel Graphs that cover time periods ranging from several months to more than one year.

### **5.2.2 Tank Tightness Testing**

Tank tightness testing is conducted semi-annually in accordance with 40 CFR 280 for all in-service storage tanks and surge tanks. The tank tightness testing system is Mass Technology Corporation's Mass Technology Precision Mass Measurement System (MTPMMS). It uses a flexible probe inserted to the bottom of the tank through the gauge port on the top of the tank. The device measures the differential pressure between a point at the bottom of the tank and another point immediately above the surface of the fuel, over a period of 5 days when the tank is closed to any fuel transfer. At the conclusion of the test, the tester conducts a statistical trend analysis of the pressure data to determine whether a leak exists. The test can detect a total leak of as little as 0.5 gph, with a 95 percent confidence level and a 5 percent probability of false alarm.

### **5.2.3 Groundwater Monitoring**

Groundwater samples are collected from 16 monitoring wells, five of which are located within the LAT and eleven of which are located outside the tunnel facility. Samples are analyzed for chemicals of potential concern and free product quarterly. Drinking water from the Navy Supply Well 2254-01 is routinely sampled and tested to safe drinking water standards. See Section 8.5 for further details.

### **5.2.4 Soil Vapor Monitoring**

See Section 8.6 for further details.



## 6.0 ENVIRONMENTAL SETTING

The following information is extracted in part from the Red Hill Bulk Fuel Storage Facility Final Technical Report, Pearl Harbor, Hawaii, August 2007.

### 6.1 Surrounding Population

Oahu is the center of economic activity for the Hawaiian Islands. Honolulu, located in the south-central portion of the island, is heavily urbanized and densely populated. The RHFSF lies at the northern edge of this urbanized area. This urbanized area stretches from the southern coast of Oahu northward, occupying the majority of the coastal plain.

Oahu (Honolulu County) has a population of approximately 953,207 people (2010 census). Populated areas closest to the RHFSF include Pearl City and Aiea to the west and Honolulu to the south and east. The population of this area is approximately 447,774 according to the 2010 census. To the southwest of the RHFSF is a U.S. Coast Guard and Navy housing complex in the Aliamanu Crater and a residential area located in Moanalua Valley. Joint Base Pearl Harbor-Hickam also lies to the southwest of the RHFSF with a population of approximately 66,300 (US Navy, 2014).

### 6.2 Land Use and Zoning

The City and County of Honolulu, Department of Planning and Permitting zoning information, indicates that the RHFSF is located on Federal government land (zoned F-1, Military and Federal) with public land located to the immediate north and northeast (zoned P-1, Restricted Parkland). Halawa Correctional Facility is located in the residential area north of the public land (zoned R-5, Residential). The RHFSF is bordered by an industrial development to the north and northwest (zoned I-2, Intensive Industrial) and a quarry to the north and northwest beyond the Halawa Correctional Facility (zoned Ag-2, General Agricultural). See Figure 6.1 for a zoning map of the area.

The John A. Burns Freeway (Interstate H-3) is located to the northwest. Moanalua Village (a residential development), is located immediately adjacent, and south to east of the RHFSF (zoned R-5, Residential). Moanalua Golf Course (zoned P-2, General Parkland and R-5, Residential), a small section of public land (zoned P-1, Restricted Parkland), and the Tripler Army Medical Center (TAMC) (zoned F-1, Military and Federal) are located further south.

A high cliff face with a 100 to 200 feet elevation difference is present between the Facility, and both Moanalua Village and the Moanalua Golf Course. Northeast of the Facility, is public land, which is mostly forested (zoned P-1, Restricted Parkland), and to the east of the Moanalua Village residential development is Moanalua Valley Park (zoned P-2, General Parkland) followed by additional public land (zoned P-1, Restricted Parkland).

Residences, townhouses and apartment buildings are located to the southwest of the Facility (zoned A-2, Apartment), and a public school (Red Hill Elementary School) is also present in this area. The RHFSF continues to the west, and is adjacent to the U.S. Coast Guard Reservation which borders Highway 78. The closest residential property to the RHFSF is the area zoned for apartment buildings located approximately 305 feet southwest of Tank 2. Red Hill Elementary

School is located approximately 1,080 feet southwest of Tank 2. The Moanalua Village residential development is located approximately 880 feet south of Tank 2. The area zoned for apartment buildings is located approximately 2,113 feet southwest of Tank 20 (the tank farthest to the east), and Red Hill Elementary School is located approximately 2,850 feet from Tank 20. The Moanalua Village residential development is located approximately 875 feet south of Tank 20.

The USDA identified no agricultural lands of importance to the State of Hawaii in the immediate vicinity of the Facility (USDA, 1977).

### **6.3 Soils**

Soils in the vicinity of the RHFSF are mapped as Helemano-Wahiawa association consisting of well-drained, moderately fine textured and fine textured soils. These soils are formed from material weathered from basalt and typically range from nearly level to moderately sloping. These soils typically occur in broad areas dissected by very steep gulches.

In the vicinity of the RHFSF, soils consisting of clays and clayey gravels are common to a depth of 10 feet below ground surface. Along the slopes and over much of the open area south of the Schofield Saddle, the basaltic bedrock is covered with 10 to 30 feet of Koolau residuum. These soils were derived from the weathering of the underlying basalt bedrock or were deposited as alluvium/colluvium. The younger alluvium/colluvium deposits were derived from fractured basalts and tuff. Beneath the surficial soils, alternating layers of clay and fractured basalts are present at depth. The western slope of the Halawa Valley is generally barren of soil and consists of outcropping of basalt lava flows to the valley floor.

### **6.4 Geology**

Red Hill is located on the southern edge of the Koolau Range, approximately 2.5 miles northeast of JBPHH. The Koolau formation consists almost entirely of basaltic lava flows that erupted from a fissure line approaching 30 miles in length and trending in a northwest rift zone. During a volcanic quiet period, valleys approaching 600 meters in depth were cut into the Koolau volcanic range as result of erosion, allowing sediment to accumulate in the valley floors. The erosion of the Koolau volcano resulted in the formation of a delta of sediment consisting of silt and sand. The delta increased in thickness as it approached the sea.

Both pahoehoe and a'a lava flows are present in the Koolau formation. Pahoehoe lava is characterized by relatively thin-bedded basaltic flows. It is smooth, fine-grained lava with a rope-like appearance and is characterized by thin-walled vesicles. A'a lava is a jagged, blocky lava flow that contains clinker (coarse rubble). These clinker beds are the more permeable feature of the a'a lava. The a'a lava is typically found in more abundance in the lower flanks of the Koolau Range.

The Facility lies along a topographic ridge between the Halawa and Moanalua Valleys. The ridge is a remnant of the original Koolau shield volcano flank and it is composed of basaltic lava flows. The valleys on either side of the ridge are a result of fluvial erosion and are filled with alluvium/colluvium. Soil boring at the RHFSF indicates that the area is predominantly underlain by pahoehoe lava. See Figure 6.2 for a geologic map of the area.

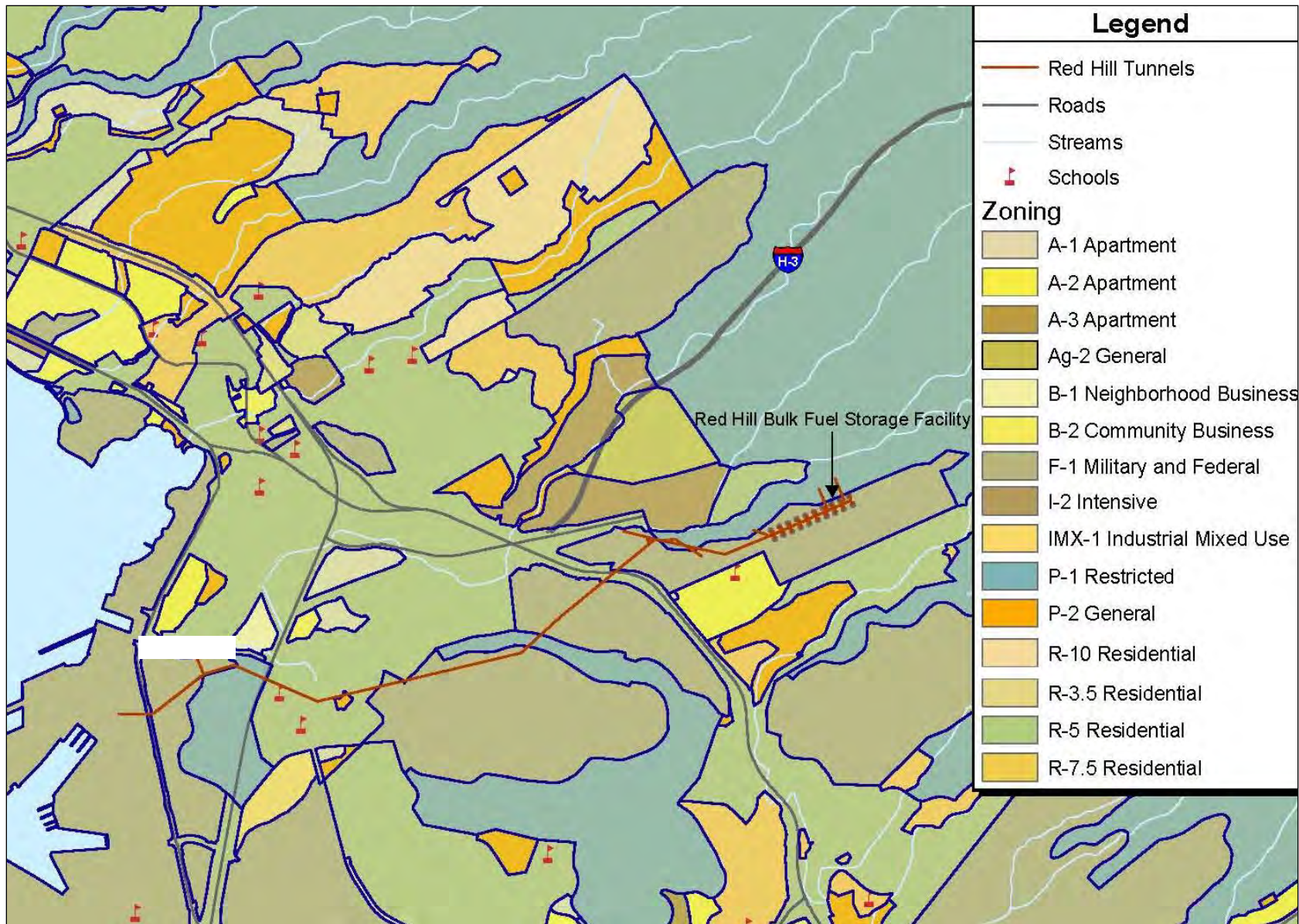

Figure 6.1: Zoning Map

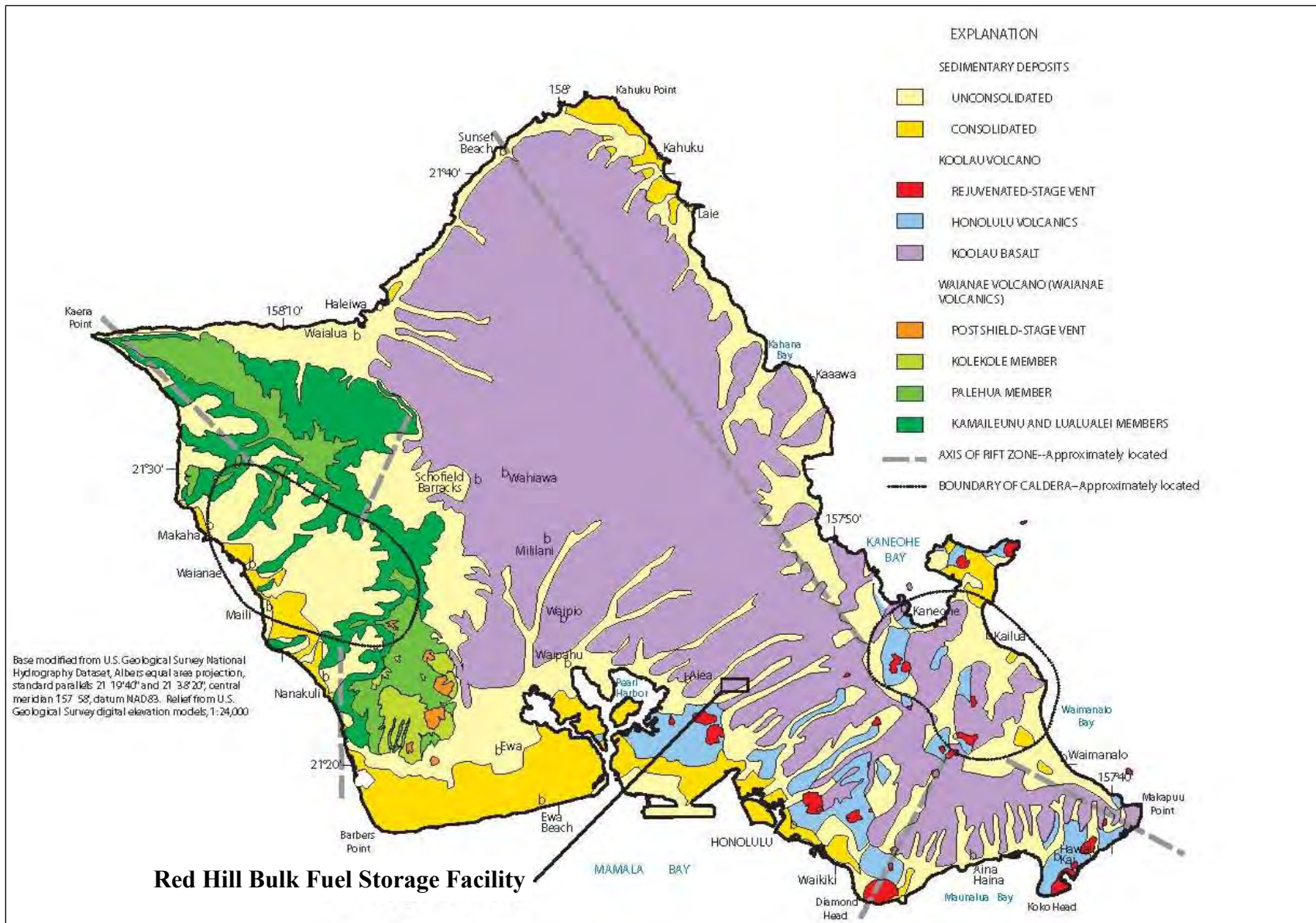

Figure 6.2: Geologic Map of Oahu

## 7.0 ENVIRONMENTALLY SENSITIVE AREAS

The following information is extracted in part from the Red Hill Bulk Fuel Storage Facility Final Technical Report, Pearl Harbor, Hawaii, August 2007.

### 7.1 Local Flora

The RHFSF is covered by the following vegetation types:

- Haole Koa (*Leucaena Leucocephala*) scrub
- Disturbed habitat
- Vegetation communities in developed areas

Haole Koa scrub grows throughout Oahu, primarily in areas that have been disturbed by grazing or human activities. The scrub community on Red Hill is dominated by *Haole Koa*, Guinea Grass (*Panicum Maximum*) and Chinese Violet (*Asystasia Gangetica*). Disturbed habitat is comprised of weedy plant species that can withstand frequent disturbance. The species in this community are similar to those found in nonnative grasslands. These disturbed habitats have a higher amount of non-grass species and sparsely covered areas. The developed habitats are near buildings, roads, or other structures with small amounts of vegetation (i.e., lawns and ornamental bushes). Native and sensitive species were not observed, as the appropriate habitat is not present.

### 7.2 Threatened and Endangered Species and Critical Habitat

No native or sensitive species are located in the area of the RHFSF. Critical habitat that supports the *Elepaio* (a native bird species) is located over 1.2 miles to the northeast and southeast of the RHFSF. Critical habitat that supports native plant species is also located over 1.4 miles to the northeast of the RHFSF. Three segments of the Honolulu Watershed Forest Reserve, a segment of the critical habitat for the *Elepaio* bird, and a portion of a wildlife management area are located over 1.7 miles to the southeast of the RHFSF. It is unlikely that a POL discharge from the RHFSF would impact these species.

The endangered Opeapepe or Hawaiian Hoary Bat (*Lasiurus Cinereus Semotus*) occurs in both the Waianae and Koolau Mountain Ranges on Oahu, but overall the population on Oahu is relatively sparse compared to other main Hawaiian islands such as Hawaii, Maui, and Kauai. Even though they may occur in low numbers, bats on Oahu can cover a significant amount of terrain, ranging from high elevation mountain areas to coastal areas at sea level. Bats have not been detected at Red Hill; however acoustic surveys have detected bats during the fall in areas around Pearl Harbor. Red Hill has very little roosting habitat for the Hawaiian Hoary Bat, but it is probable that occasionally bats are foraging in and around Red Hill. It is unlikely that a POL discharge from the RHFSF would impact bats, unless the discharge resulted in the removal of trees.

No natural area reserves, preserves, seabird sanctuaries, State monuments, State parks, State park reserves, State waysides, wildlife refuges, hunting areas, or trails are located within the vicinity of the RHFSF. Pearl Harbor, Salt Lake, and the streams near the RHFSF are identified as the nearest wetlands. Coastal resources are at least 3 miles from the RHFSF, and are not considered to be areas of concern for the RHFSF.

THIS PAGE INTENTIONALLY LEFT BLANK

**8.0 GROUND WATER AND HYDROLOGY**

**8.1 Surface Water**

Surface water features in the vicinity of the tank farm include South Halawa Stream (approximately 600–800 ft to the north), North Halawa Stream (approximately 4,000–4,500 ft to the northwest), and Moanalua Stream (approximately 1,700–2,000 ft to the south) (Figure 1-1). Potential recharge (runon and operational water use) from the Halawa Quarry north of the tank farm area may also impact groundwater flow in this area. In the area of Halawa Valley, stream flow is isolated from the basal groundwater table and is over deeply weathered rock. These flows may contribute water to perched groundwater within alluvial material (valley fill). Most precipitation percolates to the freshwater-lens aquifer and does not maintain base flows in the streams (Izuka 1992). Groundwater that flows beneath the Facility does not intercept surface water inland of the ocean shoreline (DON 2007). Both South Halawa Stream and Moanalua Stream (to the north and south of Red Hill ridge, respectively) are located approximately 100 ft or more above the groundwater table in the vicinity of the Facility. The bottoms of the Facility’s fuel storage tanks are located at least 50 ft below the bottom of these streams

**8.2 Groundwater Usage**

[REDACTED]

[REDACTED] and provides between 2.4 and 4.4 million gallons of water per day for the JBPHH Water System. The well is [REDACTED]. Water is pumped from a 110-foot deep well shaft with a bottom elevation of -10 feet. Near the bottom of the well [REDACTED]. The water development [REDACTED]. This [REDACTED] heads [REDACTED] toward the storage tanks. It crosses beneath the [REDACTED] then turns [REDACTED] passes [REDACTED]. A lava tube cross cuts the water development tunnel [REDACTED] the end of the tunnel. The length of the lava tube is unknown. There is continuous water flow at the end of the water development tunnel.

The Halawa Shaft Supply Well [REDACTED] is located [REDACTED]. This drinking water well is approximately [REDACTED] of the RHFSF and pumps water from the basal aquifer. On average, the pumping rate is [REDACTED] from this location (NAVFAC 2019). It is highly unlikely that a POL discharge from the RHFSF would impact this well. Figure 8.1 shows the location of both wells in relation to the RHFSF.

**8.3 Aquifers and Groundwater Movement**

The western part of the RHFSF overlies the Waimalu Aquifer system, which is part of the Pearl Harbor Aquifer sector, and the eastern portion overlies the Moanalua Aquifer system, which is part of the Honolulu Aquifer sector. Both the Moanalua Aquifer and Waimalu Aquifer systems

are classified as unconfined, basal, and flank. Their status is listed as a currently used, fresh drinking water source that is irreplaceable and has a high vulnerability to contamination.

On the basis of water table measurements conducted in wells near the RHFSF, the basal groundwater surface is approximately 21 feet above mean sea level. Groundwater flow in the Red Hill area is expected to travel approximately parallel to the ridge, with the valley fills in North Halawa Valley (northwest) and Moanalua Valley (southeast) channeling the flow in the westerly to southwesterly direction toward Aliamanu Crater. It should be noted that the Red Hill Ridge is not a hydrogeologic boundary, and there are no geochemical or physical attributes that separate the two aquifers at this location. The likely physical boundary between the Moanalua and Waimalu Aquifer systems is the North Halawa Valley fill, which extends below the water table in the vicinity of the RHFSF and consists of low permeable sediments.

Figure 8.2 presents Oahu's different aquifer sectors along with their sustainable yields in relation to the RHFSF. Figure 8.3 presents the RHFSF in relation to aquifers and the classification codes and status codes for the aquifer systems in the vicinity. Figure 8.4 presents groundwater areas and generalized directions of groundwater movement on the island of Oahu.

#### **8.4 Groundwater Protection Plan**

The Red Hill Bulk Fuel Storage Groundwater Protection Plan was developed to mitigate the risks associated with inadvertent releases of fuel from the RHFSF. The plan was published in 2008 (revised in 2009) and was reviewed and updated in 2014. The plan presents a strategy designed to ensure that the RHFSF and Navy Supply Well 2254-01 continue to operate at optimum efficiency in the future. The plan focuses on long-term mitigation, and is not an emergency response plan. The plan documents steps to be taken to prevent unacceptable risks associated with releases at the RHFSF. These steps include:

- Implementation of a tank inspection and maintenance program.
- Description of soil vapor monitoring (SVM) program.
- Description of groundwater sampling and risk assessment.
- Implementation of a groundwater monitoring program that will provide warning of potential unacceptable risks to human health.
- Establishment of responsibilities and response actions that will be implemented when groundwater action levels are exceeded.
- Periodic market survey to evaluate best available leak detection technologies for large field-constructed fuel storage facilities, such as the RHFSF.

#### **8.5 Groundwater Monitoring Program**

In accordance with the Red Hill Bulk Fuel Storage Groundwater Protection Plan and Hawaii Administrative Rule 11-280.1, groundwater testing is performed at both the RHFSF and U.S. Navy Supply Well 2254-01. Currently, groundwater samples are collected from 16 monitoring locations both within the RHFSF boundary and at the Halawa Correctional Facility (see Figure 8.5). Samples are analyzed for chemicals of potential concern and free product quarterly. Drinking water from the Navy well is routinely sampled and tested to safe drinking water standards.



Based on the levels of contamination detected at each monitoring location, the monitoring location is assigned to a category, as indicated below. Response actions depend both on the monitoring location at which the contamination was detected and the concentration level indicated in the sampling results.

- Category 1: This category applies to concentration levels for each chemical of potential concern. The detection limit is the smallest concentration that can be detected in the groundwater samples. The Environmental Action Level (EAL) represents the concentration level that could pose a potential adverse threat to human health and the environment. This category requires the least action by the Navy.
- Category 2: This category also applies to concentration levels for each chemical of potential concern. If the sampling events indicate an increasing trend in concentration levels or if the EAL is exceeded, the number of actions to be taken by the Navy increases.
- Category 3: This category only applies to concentration levels of benzene and Total Petroleum Hydrocarbons (TPH). Site-Specific Risk-Based Levels (SSRBLs) for Benzene and TPH were developed because these contaminants are risk drivers for migration of fuel in the groundwater. The SSRBL also represents the concentration level at the RHFSF that could potentially impact the water quality at the Navy well. If the concentration levels fall within this category, the number of required actions increases. Note: SSRBLs for Benzene and TPH are 750 and 4,500 micrograms per liter, respectively.
- Category 4: As above, this category only applies to benzene and TPH contaminants. A monitoring location is placed in this category if the established SSRBL is exceeded. This category requires the highest level of response from the Navy.

Contaminants tested include: benzene, ethylbenzene, methyl tert butyl ether, toluene, xylenes, acenaphthene, benzo(a)pyrene, fluoranthene, naphthalene (volatile organic compounds and polynuclear aromatic hydrocarbons), lead, TPH (diesel range organics and gasoline range organics).

As part of the groundwater-monitoring program, the Navy maintains a complete database of laboratory analytical results from the groundwater sampling events and evaluates concentration trends for chemicals of potential concern over time and with respect to the Hawaii Department of Health (DOH) drinking water EALs. Groundwater is also monitored for concentrations that may indicate that liquid fuel may be in direct contact with groundwater beneath the tanks. The Navy submits concentration trend data and comparisons of sampling results to drinking water EALs to DOH quarterly. See Sections 3, 4, and Appendix C, of the Red Hill Bulk Storage Groundwater Protection Plan for more information on the RHFSF groundwater monitoring program.

## **8.6 Soil Vapor Monitoring System**

The soil vapor monitoring system consists of SVMP beneath each of the 18 active tanks. Tanks 1 and 19 were removed from service in the 1980s and lack SVMPs. Most SVMP are monitored at three different depths (shallow, middle, and beneath each tanks) for Volatile Organic Compounds (VOCs) using a Photo-Ionization Detector (PID). SVMPs were given a SV prefix, followed by the associated tank number, and then the location under the tank: “S” for shallow or front of the UST, “M” for mid depth or middle of the UST, and “D” for deep or outer edge of the UST. Total VOCs are measured down to 1 part per billion and compared to baseline

measurements from the same location. Increasing concentrations over time are a possible indication of fuel leaks at the tested tank. Results are reported monthly to the DOH as required by the Red Hill Bulk Storage Groundwater Protection Plan. The Navy has collected and reported monthly soil vapor for VOCs to the DOH since 2008.

### **8.7 Groundwater Model Simulations**

According to the Red Hill Bulk Storage Groundwater Protection Plan, groundwater model simulations have shown that an extended light non-aqueous-phase liquid (LNAPL) fuel plume of jet propellant (JP-5 or F-24) within 1,099 feet of the Navy Supply Well 2254-01 infiltration gallery resulted in benzene concentrations greater than the Federal maximum contaminant level (MCL) of 5 µg/L in the infiltration gallery. It was estimated that a release as small as 16,000 gallons of JP-5 near Tanks 1 or 2 could result in this condition. The groundwater-monitoring program provides SSRBLs for TPH (4.5 mg/L) and benzene (0.75 mg/L). These are used as indicators that LNAPL may be present.

The Navy/DLA has recently established a Groundwater Modeling Working Group to better collaborate with DOH, EPA, Honolulu Board of Water Supply (BWS), U.S. Geological Survey, University of Hawaii, Engineering firm AECOM, and GSI Environmental in developing a new groundwater model. The working group has developed an interim groundwater model that greatly improves the understanding of the aquifer under the RHFSF. The interim model indicates groundwater flows from the facility to the Navy well.

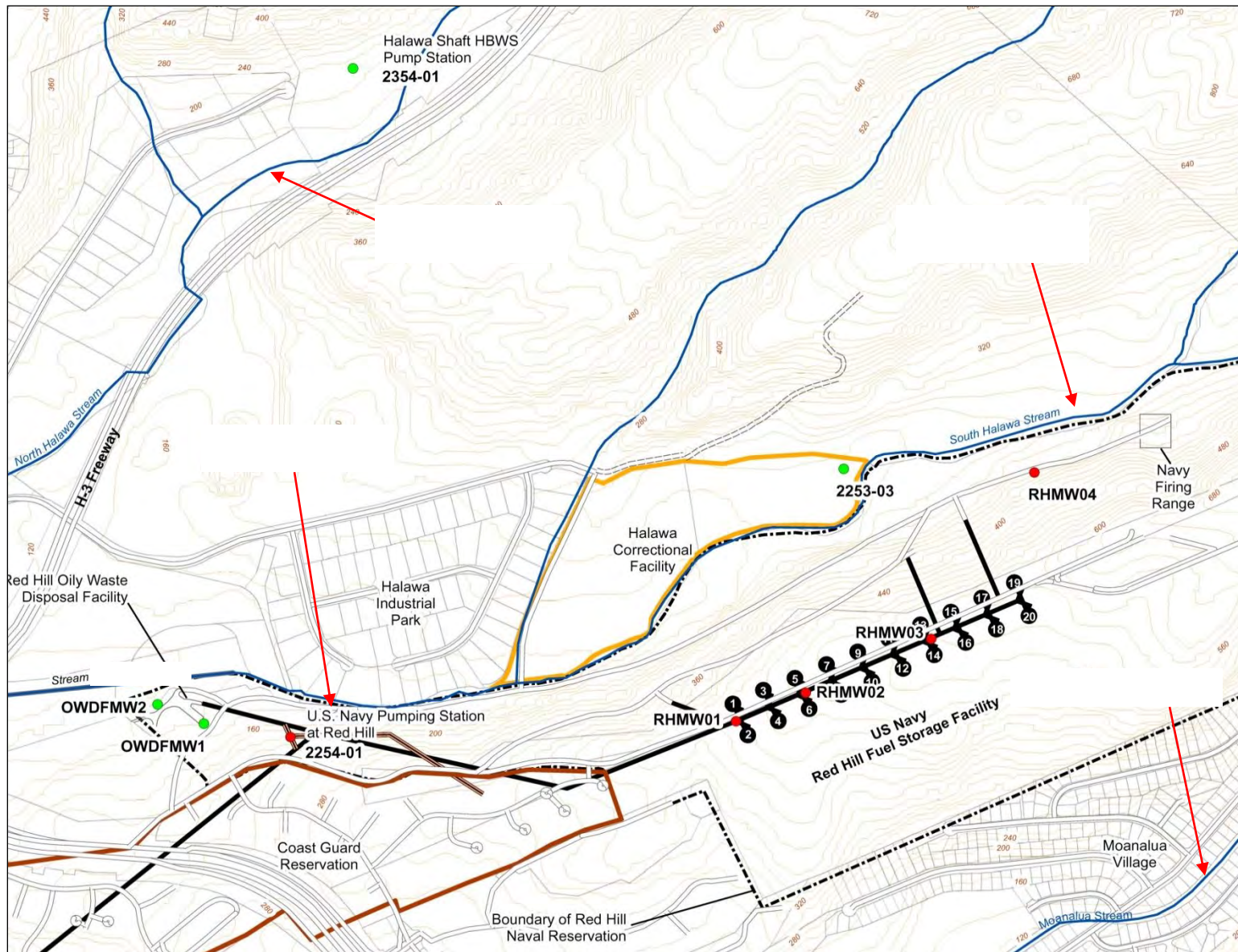

Figure 8.1: Land Use and Stream Locations in Relation to the RHFSF

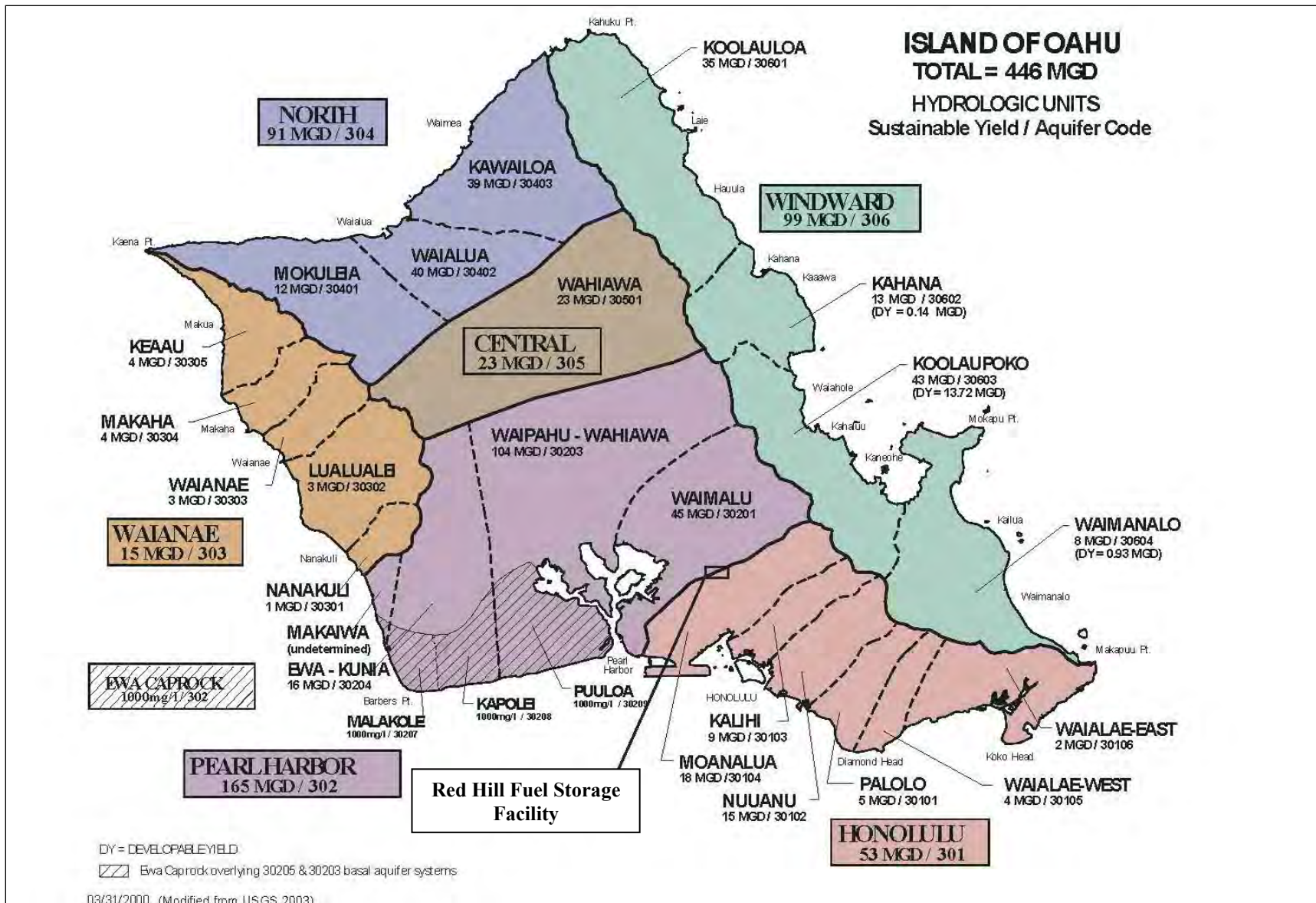
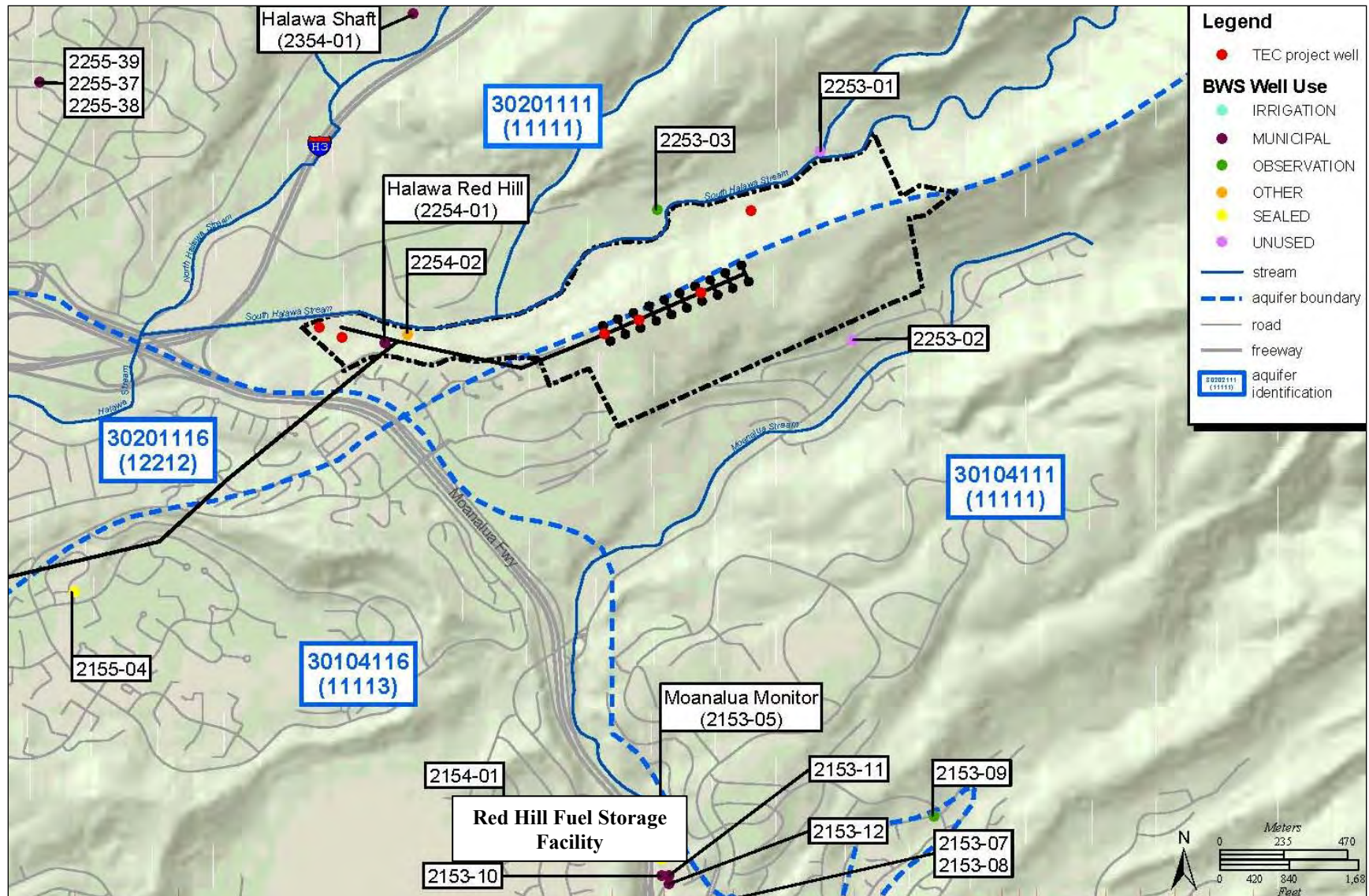
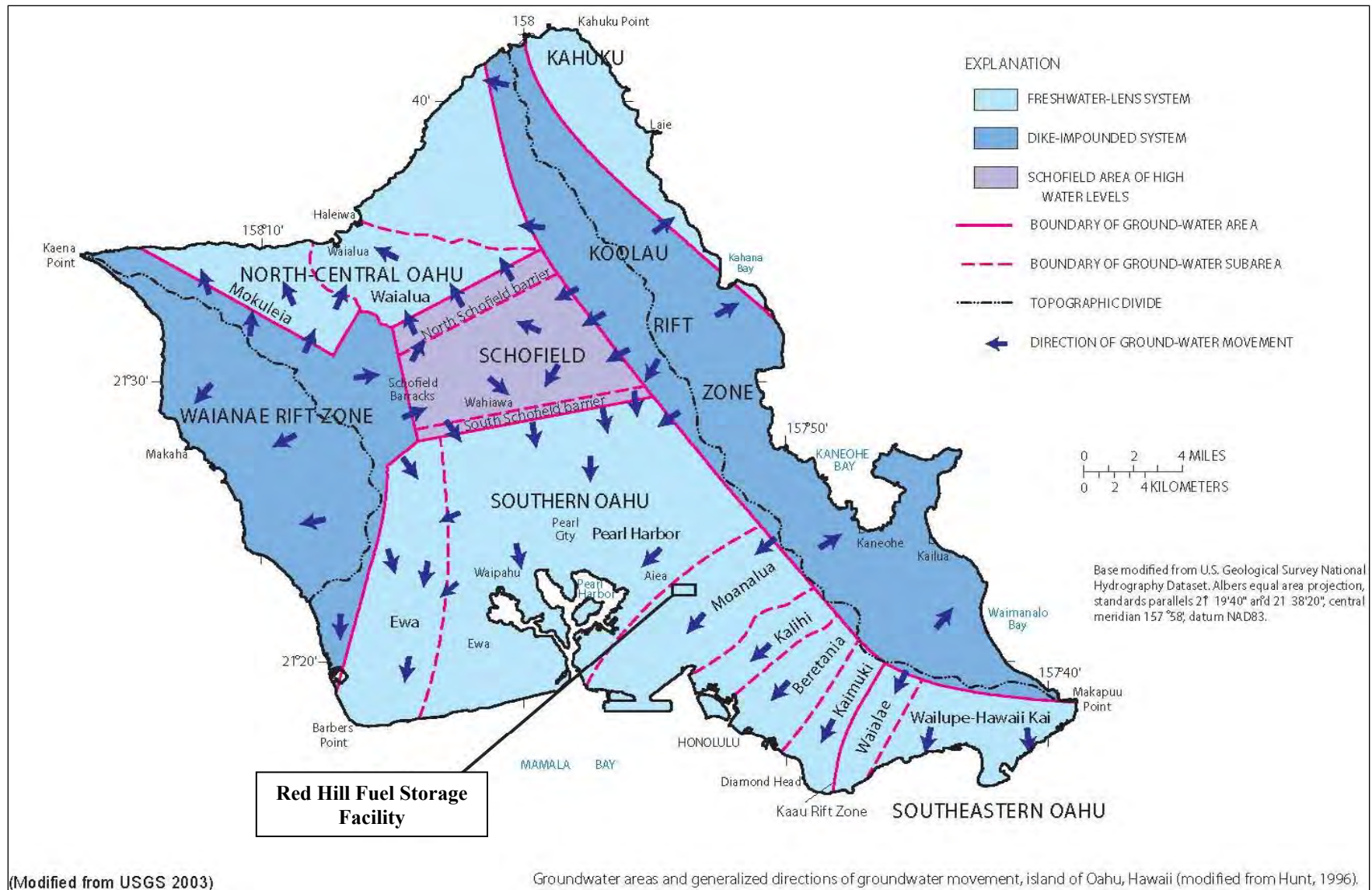

Figure 8.2: Oahu's Aquifer Sectors



Source Data: City and County of Honolulu, GIS base layers DLNR Board of Water Supply, 2005 water supply well IDs.

Figure 8.3: Area Wells and Aquifer Systems



**Figure 8.4: Regional Groundwater Flow by Aquifers**

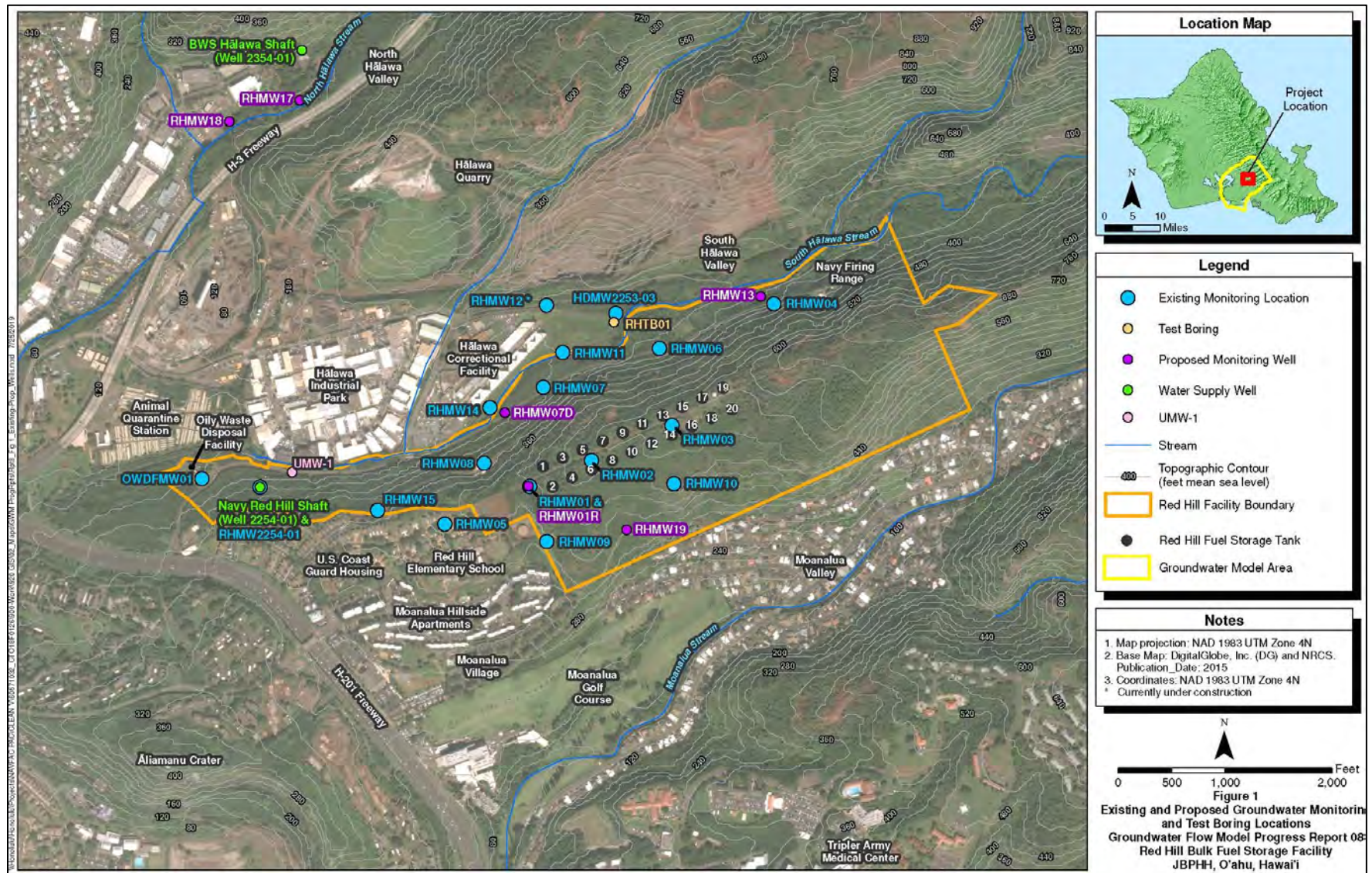

Figure 8.5: Groundwater Monitoring Well Locations

THIS PAGE INTENTIONALLY LEFT BLANK



## 9.0 SITE SAFETY INFORMATION

### 9.1 General Safety Information

The safety and security of response and support personnel and others involved in an emergency response incident is the primary concern. The section on health and safety provides a general framework for the protection of oil spill response workers' health and safety and complies with the requirements of State and Federal laws.

The information contained in the health and safety section should be used as a guide by the Safety Officer for preparing and implementing worker health and safety protection measures in order to maximize safety and allow critical oil spill response activities to proceed. Specific site control and emergency response procedures must be developed using forms provided in this outline or other forms developed for this activity. Other procedures for activities such as confined space entry or hot work will require additional controls in order to fulfill the regulatory requirements. The Safety Officer must identify these and other health and safety and regulatory matters. Once identified, the Safety Officer will need to take appropriate action to address those safety issues or regulatory requirements.

### 9.2 Medical Monitoring

All persons who will be exposed or will have the potential to be exposed to hazardous substances will take part in a medical monitoring program that meets the requirements of 29 CFR 1910.120(f). In general, medical monitoring will be conducted for workers as follows:

- Workers who have the potential to be exposed to hazardous substances at or above the permissible exposure limit (PEL).
- Workers whose duties require them to wear a respirator for more than 30 days/year.
- Workers who are believed to have been exposed to hazardous substances or who exhibit symptoms of exposure.

### 9.3 Primary Chemical Hazards

The following table lists petroleum products stored in bulk in the RHFSF.

<b>Product</b>	<b>TWA<sup>1</sup> (Time-Weighted Average)</b>	<b>STEL<sup>1</sup> (Short Term Exposure Limit)</b>
F-76 (diesel fuel marine)	39 ppm	112 ppm
JP-5 (jet fuel)	42 ppm	120 ppm
F-24 (jet fuel)	44 ppm	125 ppm

Note 1: Values listed are recommendations obtained from "Permissible Exposure Levels for Selected Military Fuel Vapors," National Academy Press, Washington DC, 1996. There are no threshold limit value (TLV) recommendations available from ACGIH or PEL requirements found in 29 CFR 1910.1000.

Safety Data Sheets (SDS) for F-76, JP-5, F-24, and all other products and hazardous chemical substances used at the RHFSF must be on file in each work area where the material is stored or handled. Availability can be through paper copies or electronic access. Example SDSs of the above listed products in Table 9.1 can be found in Appendix E.

### **9.3.1 F-76 (Diesel Fuel Marine)**

Aspiration of liquid into the lungs may cause extensive pulmonary edema (dry land drowning). Prolonged or repeated skin contact will remove skin oils leading to irritation and/or dermatitis. High vapor concentrations are irritating to the eyes and lungs, and may cause headaches, dizziness, and unconsciousness.

### **9.3.2 JP-5 (Jet Fuel)**

JP-5 is a mixture of light hydrocarbons and naphthalene. Naphthalene is a potential irritant to eyes, skin and lungs and may cause changes to the blood, eyes, and kidney after prolonged or repeated exposure. Aspiration of this product into the lungs can cause chemical pneumonia and can be fatal.

### **9.3.3 F-24 (Jet Fuel)**

F-24 is a mixture of hydro-treated light petroleum distillates, antioxidant, anti-static, corrosion inhibitor and metal deactivator. Health studies have shown that petroleum hydrocarbons pose potential human health risks that may vary from person to person. As a precaution, exposure to liquids, vapors, mists, or fumes should be minimized.

Exposures to high concentrations may cause headaches, dizziness, anesthesia, drowsiness, unconsciousness, and other central nervous system effects, including death.

### **9.3.4 Chemical Exposure**

Over-exposure to chemicals can result in significant health issues to the respiratory system, a variety of internal organs, the skin, and the eyes.

The respiratory is the primary route of entry for most toxic substances. Chemicals can irritate the large and medium sized tubes that provide air to the lungs. This irritation can cause an increase in mucus production, which can lead to the development of a continuing cough and a condition called chronic bronchitis. Continued irritation can lead to infections that can either damage the air sacs, leading to emphysema; or cause them to fill with fluid, leading to pulmonary edema. Particulates, such as dusts, may enter the lungs, creating a condition called pulmonary fibrosis. Pulmonary fibrosis occurs when the lungs are not able to remove the dust. This results in the production of scar tissue in the area of the dust impact, which destroys the ability of the air sac to do its job.

Chemical exposure can impact the liver and/or kidneys. Hepatitis (inflammation of the liver) can be caused by exposure to various chemicals. A severe case of hepatitis can lead to cirrhosis of the liver, which can result in liver scarring and reduced liver function. Chemical exposure can affect the ability of the kidneys to do their job. Over-exposure can result in a condition called uremia, which is when the chemicals produced by the body are allowed to build up.

Skin exposure can result in a variety of diseases, including: contact dermatitis – irritation of the skin where the irritant has direct contact with the skin; industrial dermatitis – irritation of the skin resulting from exposure to chemical irritants; and allergic sensitization dermatitis – repeated or frequent chemical contact which results in an allergic reaction. Dermatitis symptoms can range

from a slight reddening of the skin and mild itching to open sores, which may or may not be swollen. Over-exposure to certain chemicals can result in chemical burns. The severity of the burn depends on the chemical, the temperature of the chemical, and the duration of the contact. Like heat burns, chemical exposure can result in first, second, or third degree burns.

Eyes are particularly susceptible to industrial damage. Chemical splashes can damage the cornea, conjunctiva, or lens. Chemical burns to the eye (from exposure to acids or alkalis) can produce scar tissue on the cornea. Foreign objects, including dusts and other solid particulates, can cause irritation, or in some cases, infection and serious damage.

#### 9.4 Secondary Chemical Hazard Identification

Oil and hazardous substance spill responses may require the responder to come into contact with a wide variety of chemicals and materials which may singularly or in conjunction with the site work conditions create various hazards to site workers. Several of these hazards are identified in the following table.

Subjecting response personnel to the hazards identified above can be avoided though the use of the proper Personal Protective Equipment (PPE) and through proper monitoring and supervision by health and safety personnel. The paragraphs following Table 9.2 provide additional information for some of the secondary hazards.

TABLE 9.2: SECONDARY CHEMICAL HAZARDS		
Hazard Description	Recommended Protective Equipment	Conditions Under Which Exposure May Occur
<b>Confined Spaces.</b> Inadequate ventilation coupled with limited egress creates potentially hazardous situations for workers. Oxygen deficient, toxic or flammable atmospheres may exist in these areas. All Occupational Safety and Health Administration (OSHA) procedures regarding confined space entry will be followed.	Monitor CO, O <sub>2</sub> , toxic and flammable gas levels, and ventilate area. Do not enter a confined space without a confined space entry permit and supervision from the Safety Officer. Safe O <sub>2</sub> levels = 19.5% to 23.5%; flammable gas limits = less than 10% LEL; toxic limits = less than ½ PEL or Threshold Limit Value (TLV) - whichever is the lower value.	Confined spaces may be encountered on vessels, inside tanks, inside buildings, in tunnels, in sumps, in ditches, etc. Product vapors or other emissions resulting from response operations may intensify this hazard.
<b>Diesel and Gasoline Engine Exhaust.</b> Exposure to diesel or engine exhaust may promote inhalation of hydrocarbons, carbon monoxide and particulates. Exposure may irritate eyes and mucous membranes.	Monitor CO and O <sub>2</sub> levels, ventilate area, and use half-mask respirator with organic and particulate filters.	Diesel and gasoline exhaust exposure may occur in poorly ventilated areas in the vicinity of internal combustion equipment. It may also occur in sheltered outdoor areas on calm days or during temperature inversion conditions.
<b>Particulates.</b> Particulates may cause irritation to lungs, eyes, and mucous membranes. Particulates may also have toxic effects (e.g., lead, asbestos, cadmium, and silica).	Use half-mask respirator with particulate filter and appropriate cartridges. Use other PPE for eye and skin protection as needed.	Use powdered or granular oil absorbent (diatomaceous earth, vermiculite, etc.) or other specialty products where particles become airborne and enter the breathing zone of personnel. Wind carried silts, and other dusts may also be a factor.

**TABLE 9.2: SECONDARY CHEMICAL HAZARDS**

Hazard Description	Recommended Protective Equipment	Conditions Under Which Exposure May Occur
<p><b>High Carbon Monoxide Levels.</b> Carbon monoxide is a colorless and odorless gas, slightly less dense than air and is toxic by inhalation. Carbon monoxide is also highly flammable. Carbon monoxide will cause chemical asphyxiation because it binds to hemoglobin 300 times faster than oxygen. If high concentrations are present, incapacitation or death can result in a few minutes. Exposure to concentration above 4,000 parts-per-million (ppm) can result in death in less than one hour, and concentrations as low as 1,500 ppm can cause collapse, unconsciousness, and possibly death within two hours. (Lower Explosive Limit (LEL) = 12%; Upper Explosive Limit (UEL) = 75% by volume in air)</p>	<p>Monitor CO, and ventilate area. Use of supplied air PPE is required. Do Not enter high CO atmosphere without a confined space entry permit and supervision from Safety Officer. Safe CO levels are less than 50 ppm TWA.</p>	<p>Poorly ventilated areas in the vicinity of internal combustion engines. Acetylene welding, industrial heating equipment and processes involving incomplete combustion may also create this hazard.</p>
<p><b>Flammable Atmosphere.</b> A flammable gas, vapor, mist, or dust when mixed with air may create a flammable or explosive condition. Volatile vapors or gases will generally be of a sufficient quantity during the initial few hours of a spill to cause a flammable atmosphere.</p>	<p>Conduct flammable gas and oxygen monitoring prior to starting any work. Purge or inert atmospheres when possible. Obtain hot work permits prior to starting any cutting or welding. Safe flammable limits are less than 10% of the Lower Explosive Limit.</p>	<p>Flammable conditions may exist during the initial phase of a spill or at any time in areas where flammable dusts or vapors may concentrate. Holds of vessels and fueling areas are prime locations to find flammable atmospheres.</p>
<p><b>Low Oxygen Levels.</b> Confined or restricted space atmospheres may be dangerous to life and health if O<sub>2</sub> levels are below 19.5% (oxygen deficient) or greater than 23.5% (oxygen enriched).</p>	<p>Monitor O<sub>2</sub> levels and ventilate area. Do not enter O<sub>2</sub> deficient atmosphere without a confined space entry permit and supervision from the Safety Officer. Supplied air Personal Protective Equipment (PPE) is required. Safe O<sub>2</sub> levels are between 19.5%-23.5%.</p>	<p>Poorly ventilated areas in the vicinity of oxygen consuming materials or equipment. This includes waste undergoing biological degradation or fuel powered equipment in confined or restricted spaces (e.g., tanks).</p>
<p><b>Other Spill Response Specialty Agents.</b> Due to the varied nature of oil spill cleanup operations, numerous specialty chemicals in solid, liquid, and gaseous phases may be used or stored in work areas.</p>	<p>Obtain and review SDSs for all products. Verify safety precautions and PPE needs. Obtain any required respirator, skin, eye, and splash protection.</p>	<p>Exposure to these materials in poorly ventilated areas or in open areas may occur if workers are unaware of the chemicals' toxic or physical properties.</p>

#### 9.4.1 Hazardous Conditions

The hazards associated with the contaminants listed in the above table are best controlled through early detection, use of PPE, implementation of engineering controls, or by avoiding the hazard. Using common sense and understanding the Health and Safety Plan can accomplish early detection.

### 9.4.2 Confined Space Entry

Entry into confined spaces (spaces with restricted egress and potentially hazardous atmospheres) will be conducted under the direct supervision of the Safety Officer and through the use of a confined space entry permit. Confined spaces may be oxygen deficient or have flammable or toxic atmospheres. Confined space entry will be permitted only if the parameters listed in the above table are within acceptable limits.

### 9.4.3 Low Oxygen Levels

In addition to the conditions listed in Table 9.2, oxygen deficiency can also be caused by displacement of the oxygen with other gases or vapors. Gases that pose no other hazard beyond oxygen displacement are called asphyxiants.

Physically, the first sign of oxygen deficiency is an increased rate and depth of breathing. Dizziness, rapid heartbeat, and headache may be noticed when the oxygen level is below 16%. Trouble with physical movement, semi-consciousness, and a lack of concern about the possibility of danger indicate serious oxygen deficiency. Immediate loss of consciousness will result from entrance into an area with little or no oxygen (usually 10% or below).

### 9.5 Physical Hazards

Physical hazards associated with oil spill cleanup operations are varied and the associated hazards depend upon the site-specific conditions, cleanup operations, and the type of equipment being used. Severe environmental and weather conditions, complex transportation and logistical requirements, long work hours, and intensive labor needs contribute to the high susceptibility of oil spill workers to physical hazards. Table 9.3 summarizes some of the physical hazards associated with spill cleanup operations.

TABLE 9.3: GENERAL PHYSICAL HAZARDS		
Hazard Description	Hazard Treatment Guidance	Hazard Abatement Technique
<b>Slip, Trip, Fall.</b> Oil spill responders work in places where poor footing and lighting creates slip, trip, and fall hazards.	Survey responders for possible unknown injuries. If injured, treat with first aid and seek medical attention.	Provide proper illumination in work areas. Keep work areas free of excess clutter. Move cautiously in work areas and use non-slip soles on footwear. Attempt to recognize and avoid or control hazards in the work area. Conduct hazard awareness briefings.
<b>Eye Injuries.</b> An oil spill response may expose workers to numerous eye hazards, including those resulting from chemical exposure, equipment hazards, open flames, and impacts from particulates or other foreign bodies.	If chemicals have contacted a worker's eye, flush eye with water immediately. If particulate is in the eye, flush eye with water. If an object is imbedded in the eye, do not attempt to remove it. Cover the affected eye to prevent further irritation and seek medical assistance.	Use appropriate eye protection such as safety glasses, goggles, and face shields. Avoid exposure to vapors, mists, fumes, and dusts.

TABLE 9.3: GENERAL PHYSICAL HAZARDS

Hazard Description	Hazard Treatment Guidance	Hazard Abatement Technique
<b>Back Injuries.</b> The requirement to mobilize and use great quantities of equipment during the oil spill response creates high probability of back injuries. Slips, trips, and falls contribute to back injuries.	Remove worker from the work area to prevent further stress on the worker's back. If necessary, stabilize the victim in a prone position with a backboard to prevent additional injury. Seek medical attention.	Lift objects correctly. Obtain assistance from co-workers. Use mechanical devices to reduce lifting effort. Do back and stretching exercises prior to lifting objects. Bend the legs when lifting instead of bending from the waist.
<b>Handling of Hand Tools and Spill Response Equipment.</b> Tools used in cleanup operations such as shovels, picks, axes, etc. can inflict injury to adjacent workers if adequate distance is not maintained. Improper use of tools may also cause back injuries. Sorbents, containment booms, and waste materials can be heavy and awkward and handling and moving them may cause back injuries.	If injured, treat with first aid and seek medical assistance.	Team leaders must provide orientation for workers to familiarize them with the equipment that is being used. Use hand tools in a manner that will limit physical stress. Take frequent breaks to limit fatigue. Allow water to drain from equipment prior to moving it. Use mechanical devices to handle heavy materials.
<b>Noise Injuries.</b> Sound sources that generate noise greater than 85 decibels include aircraft, outboard engines, generators, compressors, heaters, and heavy equipment. Noises that are greater than 85 decibels may cause permanent damage to hearing.	Monitor noise levels. Remove affected worker from duties that have high noise exposure potential. Provide worker with additional hearing protection equipment. Seek medical assistance as necessary.	Workers should use ear protection equipment or avoid high noise areas.
<b>Site Illumination.</b> Response operations during conditions of poor visibility or darkness may create dangerous or unhealthy conditions for response workers.	Provide substantial amounts of lighting and generator equipment. Personal headlamps and vehicle lighting may be used as supplemental lighting.	Provide adequate lighting. Use headlamps, portable lighting, and equipment lights to illuminate work sites.
<b>Specialty or Heavy Equipment.</b> Mechanical equipment may have exposed moving parts, generate heat capable of causing burns, or generate high pressure liquids or gases which may injure workers. Movement of heavy equipment may cause injuries to personnel.	Perform first aid; seek medical attention immediately.	Read all operating guide manuals. Be aware of any moving parts that may cause injury. Avoid direct exposure to heat or pressure generated by equipment. Wear appropriate PPE to limit possible injury. Install backup alarms on heavy equipment. Ensure all guards are in place.
<b>Vehicle, Aircraft, or Vessel Accidents.</b> Response efforts will in many cases require response personnel to travel by various modes of transportation. The emergency nature of the response may expose worker to marginally safe traveling conditions.	Be aware of your position at all times and know the locations of safe refuges along your intended travel route. Notify the Incident Command Post if an accident occurs and what assistance is required.	During all vehicle, aircraft, or vessel travel, workers will adhere to all established travel safety procedures. This includes fastening seat belts, maintaining communications, and wearing or having easy access to safety equipment such as life vests and survival gear.

**TABLE 9.3: GENERAL PHYSICAL HAZARDS**

<b>Hazard Description</b>	<b>Hazard Treatment Guidance</b>	<b>Hazard Abatement Technique</b>
<b>Heat Stress.</b> Heat stress may occur when a worker is exposed to elevated temperature conditions. Examples of when this may occur include worker suited in protective clothing that limits cooling of the individual and worker subjected to high ambient temperatures.	Move victim to cool, shaded location. Cool victim quickly by wrapping in wet towels. Treat victim for shock. Seek medical assistance immediately.	Taking frequent breaks to cool down and consuming large amounts of liquids may avoid heat stress. PPE can be fitted with cooling equipment. Ventilation may be used to assist with cooling. New site workers must acclimate themselves to the site conditions.
<b>Worker Exhaustion.</b> Spill response activities often involve strenuous tasks and long work hours. Symptoms of exhaustion include loss of concentration, increased frequency of slips, trips, and falls, and worker complaints of cramping and pain. Work exhaustion often manifests itself in other hazards such as accidents and back injuries.	Supervisors must closely observe workers for signs of exhaustion. Once an exhausted worker is identified, he shall be assigned to a less stressful task or removed from labor duties entirely until recovered. Seek medical assistance as necessary.	Close observation by supervisors and use of the buddy system will be used to detect and prevent worker exhaustion. Frequent breaks along with consumption of high-energy foods and liquids will also decrease the likelihood of exhaustion.
<b>Wildlife.</b> Spill workers may encounter a wide variety of wildlife during response activities. Some of the wildlife may be capable of inflicting injuries to or killing response personnel.	Treat injuries with standard first aid methods. Treat victim for shock. Seek medical assistance as necessary.	Wildlife protection procedures will be established for each specific spill event.
<b>Weather.</b> Sudden changes in weather conditions may jeopardize the safety of responders. Ocean storms, high winds, dramatic temperature changes, or fog can all pose a serious threat.	If caught in severe weather, consider options carefully. Evacuation of work site may be necessary.	Obtain daily weather forecasts and updates as available. Preplan work site evacuation plans for worst-case scenarios. Workers should bring extra clothing and emergency survival gear. Communications with the Incident Command Center must be maintained in order to coordinate evacuation or to receive support.
<b>Electric Shock.</b> Electric equipment operated at greater than 12 volts, used inlet or conductive areas, or damaged equipment can produce a severe electrical shock.	Remove victim from contact with energized parts. Administer CPR and first aid as necessary. Obtain medical assistance.	Use intrinsically safe equipment or ground fault interrupter circuits to prevent shock.

### 9.5.1 Noise

Many factors can have an influence on the ultimate effect of noise exposure. The individual's susceptibility, the intensity and frequency (highness or lowness) of the sound, the length of exposure, and the type of exposure (continuous or impact) can affect the amount of damage caused by the over-exposure. Intensity describes the pressure that the sound or noise makes and is measured in decibels. Loud noises have a high intensity (i.e. a jet engine has an intensity of approximately 130 decibels) and soft noises have a low intensity (i.e. conversation is usually measured between 40 to 50 decibels). Extremely loud and sudden noises (i.e. explosions) can actually rupture the eardrum. It is important to note that an increase of 10 decibels means a ten times increase in noise intensity.

Table 9.4 provided additional information on OSHA standards for noise level exposures.

TABLE 9.4: PERMISSIBLE NOISE EXPOSURE <sup>1</sup>	
Duration Per Day (Hours)	Permissible Exposure (Decibels)
8	90
6	92
4	95
3	97
2	100
1.5	102
1	105
0.5	110
0.25 or less	115

Note 1: As per OSHA guidance, noise exposures less than 90 decibels do not contribute to the daily dose.

When the daily noise exposure (D) is composed of two or more periods of noise exposure of different levels, their combined effect should be considered, rather than the individual effect of each. If the sum of the following formula exceeds 1, then the mixed exposure should be considered to exceed the limit and feasible administrative or engineering controls shall be used. This equation is only to be used for continuous exposure. Exposure to impulsive or impact noise should not exceed 140 dB peak sound pressure level.

$$D = C1/T1 + C2/T2 + \dots + Cn/Tn$$

**Where:**

D = Daily noise dose (must not exceed unity)

C = Actual exposure time at given noise level.

T = Permissible exposure time at that level in accordance with the table below.

**Examples:**

1. For an 8-hour workday, constant noise values are estimated to be 100 decibels for 1 hour and 90 decibels for the remaining 7 hours.

$$\text{Therefore, } D = 1/2 + 7/8 = 1.375$$

Since the result is greater than 1, engineering or administrative controls are necessary to reduce noise dose to unity.

2. For an 8-hour workday, constant noise values are estimated to be 100 decibels for 1 hour, 90 decibels for 3 hours and 85 decibels for 4 hours.

$D = 1/2 + 3/8 = 0.875$  (as per OSHA guidance, noise exposures less than 90 decibels do not contribute to the daily dose, so the 4 hours at 85 decibels does not figure into the equation)



Since the result is less than 1, no further engineering or administrative controls are necessary.

Noise monitoring must be conducted during any prolonged response operation.

## **9.6 Heat Stress Information**

Safety problems are common to hot environments, as heat tends to promote accidents due to slippery objects from sweaty palms, dizziness, or the visual distortions from fogged safety glasses.

The frequency of accidents, in general, appears to be higher in hot environments than in more moderate environmental conditions. Working in a hot environment lowers the mental alertness and physical performance of an individual. Increased body temperature and physical discomfort promote irritability, and other emotional states that can cause workers to overlook safety procedures or to divert attention from hazardous tasks.

### **9.6.1 Heat Index**

The heat index combines the effects of heat and humidity. When heat and humidity combine to reduce the amount of evaporation of sweat from the body, outdoor exercise becomes dangerous even for those in good shape. Key rules for coping with heat are to drink plenty of water to avoid dehydration and to slow down and cool off when feeling fatigued or if you develop a headache, a high pulse rate, or shallow breathing. Overheating can cause serious, even life-threatening conditions such as heat stroke. The apparent temperature, which combines the temperature and relative humidity, is a guide to the danger. Figure 9.1 provided at the end of this section to help identify the heat stress index based on the apparent temperature.

### **9.6.2 Effects of Heat Illnesses**

#### ***Transient Heat Fatigue***

Transient heat fatigue refers to the temporary state of discomfort and mental or psychological strain arising from prolonged heat exposure. Workers unaccustomed to the heat are particularly susceptible and can suffer to varying degrees, including a decline in task performance, coordination, alertness, and vigilance. The severity of transient heat fatigue can be lessened by a period of gradual adjustment to the hot environment (heat acclimatization). The use of a program of acclimatization and training for work in hot environments is advisable. The signs and symptoms of heat fatigue include impaired performance of skilled sensorimotor, mental, or vigilance jobs. There is no treatment for heat fatigue except to remove the heat stress before a more serious heat-related condition develops.

#### ***Heat Rash***

Heat rash is likely to occur in hot, humid environments where heat is not readily evaporated from the surface of the skin, leaving the skin wet most of the time. Sweat ducts become clogged, and a skin rash can develop. When the rash is extensive or complicated by infection, heat rash can be very uncomfortable and may reduce a worker's performance. Heat rash (or prickly heat) is manifested as red papules and usually appears in areas where the clothing is restrictive. As sweating increases, these papules give rise to a prickling sensation. Prickly heat occurs in skin

that is persistently wetted by unevaporated sweat, and heat rash papules may become infected if they are not treated. In most cases, the worker can prevent this condition by resting in a cool place part of each day and by regularly bathing and drying the skin.

### ***Heat Collapse (Fainting)***

A worker who is not accustomed to hot environments and who stands immobile in the heat can faint. Due to the body's attempts to control internal temperature, enlarged blood vessels in the skin and lower body may pool blood rather than return it to the heart to be pumped to the brain. As a result, the exposed individual may lose consciousness. This reaction is similar to that of heat exhaustion and does not affect the body's heat balance. Upon lying down, the worker should soon recover. Keeping active and moving around, should prevent blood from pooling, and the patient can avoid further fainting. However, the onset of heat collapse is rapid and unpredictable. To prevent heat collapse, the worker should gradually become acclimatized to the hot environment.

### ***Heat Cramps***

Heat cramps are painful spasms of the muscles that can occur during times of extreme sweating without adequate replacement of the body's salt. They are usually caused by performing hard physical labor in a hot environment. These cramps have been attributed to an electrolyte imbalance caused by sweating. It is important to understand that cramps can be caused by both too much and too little salt. Cramps appear to be caused by the lack of water replenishment. Because sweat is a hypotonic solution ( $\pm 0.3\%$  NaCl), excess salt can build up in the body if the water lost through sweating is not replaced. Thirst cannot be relied on as a guide to the need for water; instead, water must be taken every 15 to 20 minutes in hot environments. The drinking of large quantities of water tends to dilute the body's fluids, while the body continues to lose salt. Shortly thereafter, low salt level in the muscles can cause painful cramps. The affected muscles may be part of the arms, legs, or abdomen, but tired muscles (those used in performing the work) are generally the ones most susceptible. Cramps may occur during or after work hours and may be relieved by ingesting salted liquids.

Under extreme conditions, such as working for 6 to 8 hours in heavy protective gear, a loss of sodium may occur. Recent studies have shown that drinking commercially available carbohydrate-electrolyte replacement liquids is effective in minimizing physiological disturbances during recovery.

**CAUTION - PERSONS WITH HEART PROBLEMS OR THOSE ON A "LOW SODIUM" DIET WHO WORK IN HOT ENVIRONMENTS SHOULD CONSULT A PHYSICIAN ABOUT POTENTIAL HEALTH PROBLEMS.**

### ***Heat Exhaustion***

Heat exhaustion includes several clinical disorders having symptoms that may resemble the early symptoms of heat stroke. Heat exhaustion is caused by the loss of large amounts of fluid by sweating, sometimes with excessive loss of salt. A worker suffering from heat exhaustion still sweats but experiences extreme weakness or fatigue, giddiness, nausea, thirst, vertigo, or headache. Body temperature might rise, but not above 102 degrees. In more serious cases the victim may vomit or lose consciousness. The skin is clammy and moist, the complexion is pale

or flushed, and the body temperature is normal or only slightly elevated. Heat exhaustion is more likely after a few days of a heat wave than when one is just beginning. Heat exhaustion should not be dismissed lightly, however, for several reasons. One is that the fainting associated with heat exhaustion can be dangerous because the victim may be operating machinery or controlling an operation that should not be left unattended; moreover, the victim may be injured when he or she faints. Also, the signs and symptoms seen in heat exhaustion are similar to those of heat stroke, a medical emergency.

Fortunately, this condition responds readily to prompt treatment. In most cases, treatment involves resting the victim in a cool place and administering plenty of liquids. Victims with mild cases of heat exhaustion generally recover quickly. Those with severe cases may require extended care. There are no known permanent effects.

**CAUTION - PERSONS WITH HEART PROBLEMS OR THOSE ON A "LOW SODIUM" DIET WHO WORK IN HOT ENVIRONMENTS SHOULD CONSULT A PHYSICIAN ABOUT POTENTIAL HEALTH PROBLEMS.**

### ***Heat Stroke***

Heatstroke – including sunstroke – is considered to be the most severe of the heat-related illnesses. **HEAT STROKE IS A MEDICAL EMERGENCY.** Heat can have punishing effects on your body. After excessive exercise or physical labor, your body can overheat, and you may suffer heat exhaustion. In some cases, extreme heat can upset the body's thermostat, causing body temperature to rise to 105 degrees or higher. Heat cramps occur after excessive loss of water and salt; usually resulting from excessive sweating, or after strenuous exercise or labor. During heat exhaustion and heat cramps, the heat-controlling system is still intact, but can be overwhelmed. If this happens, heat exhaustion can progress to heatstroke, a life-threatening medical condition. The primary signs and symptoms of heat stroke are confusion or delirium; lethargy; irrational behavior; loss of consciousness; convulsions; a lack of sweating (usually); hot, dry, red, or spotted skin; and an abnormally high body temperature, e.g., a rectal temperature of 105°F or higher.

Heatstroke occurs when your body's thermostat cannot keep your body cool. Your body relies on water evaporation to stay cool. As your temperature rises, your body reacts by sweating. When this sweat evaporates, it cools your body. The amount of moisture in the air (humidity) determines how readily sweat evaporates. In very dry air, sweat evaporates easily, quickly cooling your body; but in very humid air, sweat does not evaporate. It may collect on the skin or run off your body without affecting your body's climbing temperature. Extremely warm and humid temperatures can quickly overwhelm your body's cooling system – particularly when the air is not circulating. When sweating can no longer keep you cool, body temperature quickly rises, causing the symptoms of heat-related illness.

Sunstroke is a type of heatstroke. In sunstroke – also called heat illness, heat injury, hyperthermia, and heat prostration – the source of heat is the sun. Other types of heatstroke occur after exposure to heat from different sources.

Even a suspicion that someone might be suffering from heatstroke requires immediate professional medical treatment. Regardless of the worker's protests, no employee suspected of being ill from heat stroke should be sent home or left unattended unless a physician has specifically approved such an order. In severe cases, heatstroke can even cause organ dysfunction, brain damage, and death. Any person showing symptoms of heat stroke requires immediate hospitalization. First aid, which should be administered immediately, includes moving the victim to a cool area, removing clothing and applying cool or tepid water to the skin, and vigorously fanning the body to promote sweating and evaporation. Give cool beverages by mouth only if the person has a normal mental state and can tolerate it. Further treatment at a medical facility should include the continuation of the cooling process and the monitoring of complications that often accompany heat stroke. The medical outcome of an episode of heat stroke depends on the victim's physical fitness and the timing and effectiveness of first aid treatment. Early recognition and treatment of heat stroke are the only means of preventing permanent brain damage or death.

### ***Preparing For Work in the Heat***

One of the best ways to reduce heat stress in workers is to minimize heat in the work place. However, there are some work environments where heat is difficult to control, such as outdoors where workers exposed to various weather conditions.

Humans, to a large extent, are capable of adjusting to the heat. Adjusting to heat under normal circumstances usually takes five to seven days, during which time the body will undergo a series of changes that will make continued exposure to heat more endurable.

Gradual exposure to heat gives the body time to become accustomed to higher environmental temperatures. Heat disorders in general are more likely to occur among workers who have not been given time to adjust to working in the heat or among workers who have been away from hot environments or who have gotten accustomed to lower temperatures. Hot weather conditions of the summer are likely to affect the worker who is not acclimatized to heat. Likewise, heat in the work environment can affect workers who return to work after a leisurely vacation or extended illness. Under such circumstances, the worker should be allowed to acclimate to the hot environment.

Heat stress depends, in part, on the amount of heat the worker's body produces while a job is being performed. The amount of heat produced during hard, steady work is much higher than that produced during intermittent or light work. One way of reducing the potential for heat stress is to make the job less strenuous or lessen its duration by providing adequate rest time.

### ***Number and Duration of Exposures***

Rather than be exposed to heat for extended periods of time during the course of a job, workers should, wherever possible, be permitted to distribute the workload evenly over the day and incorporate work-rest cycles. Work-rest cycles give the body an opportunity to get rid of excess heat, slow down the production of internal body heat, and provide greater blood flow to the skin. Workers employed outdoors are especially subject to weather changes. A hot spell or a rise in humidity can create overly stressful conditions.

***Rest Areas***

Providing cool rest areas in hot work environments considerably reduces the stress of working in those environments. Rest areas should be as close to the work area as possible and provide shade. Individual work periods should not be lengthened in favor of prolonged rest periods. Shorter but frequent work-rest cycles are the greatest benefit to the worker.

***Drinking Water***

In the course of a day's work in the heat, a worker may produce as much as two to three gallons of sweat. Because so many heat disorders involve excessive dehydration of the body, it is essential that water intake during the workday be about equal to the amount of sweat produced. Most workers exposed to hot conditions drink fewer fluids than needed due to an insufficient thirst drive. A worker, therefore, should not depend on thirst to signal when and how much to drink. Instead, the worker should drink five to seven ounces of fluids every 15 to 20 minutes to replenish the necessary fluids in the body. There is no optimum temperature of drinking water, but most people tend not to drink warm or very cold fluids as readily as they will cool ones. Whatever the temperature of the water, it must be palatable and readily available. Individual drinking cups should be provided. Never use a common drinking cup.

Heat acclimatized workers lose much less salt in their sweat than do workers who are not adjusted to the heat. The average American diet contains sufficient salt for acclimatized workers even when sweat production is high. If, for some reason, salt replacement is required, the best way to compensate for the loss is to add a little extra salt to food. Salt tablets **SHOULD NOT** be used.

**CAUTION - PERSONS WITH HEART PROBLEMS OR THOSE ON A "LOW SODIUM" DIET WHO WORK IN HOT ENVIRONMENTS SHOULD CONSULT A PHYSICIAN ABOUT POTENTIAL HEALTH PROBLEMS.**

***Protective Clothing***

Clothing inhibits the transfer of heat between the body and the surrounding environment. Therefore, in hot jobs where the air temperature is lower than skin temperature, wearing excessive clothing reduces the body's ability to lose heat to the air. When air temperature is higher than skin temperature, however clothing can help to prevent the transfer of heat from the air to the body. The advantage of wearing additional clothes, however, may be nullified if the clothes interfere with the evaporation of sweat (such as rain slickers or chemical protective clothing).

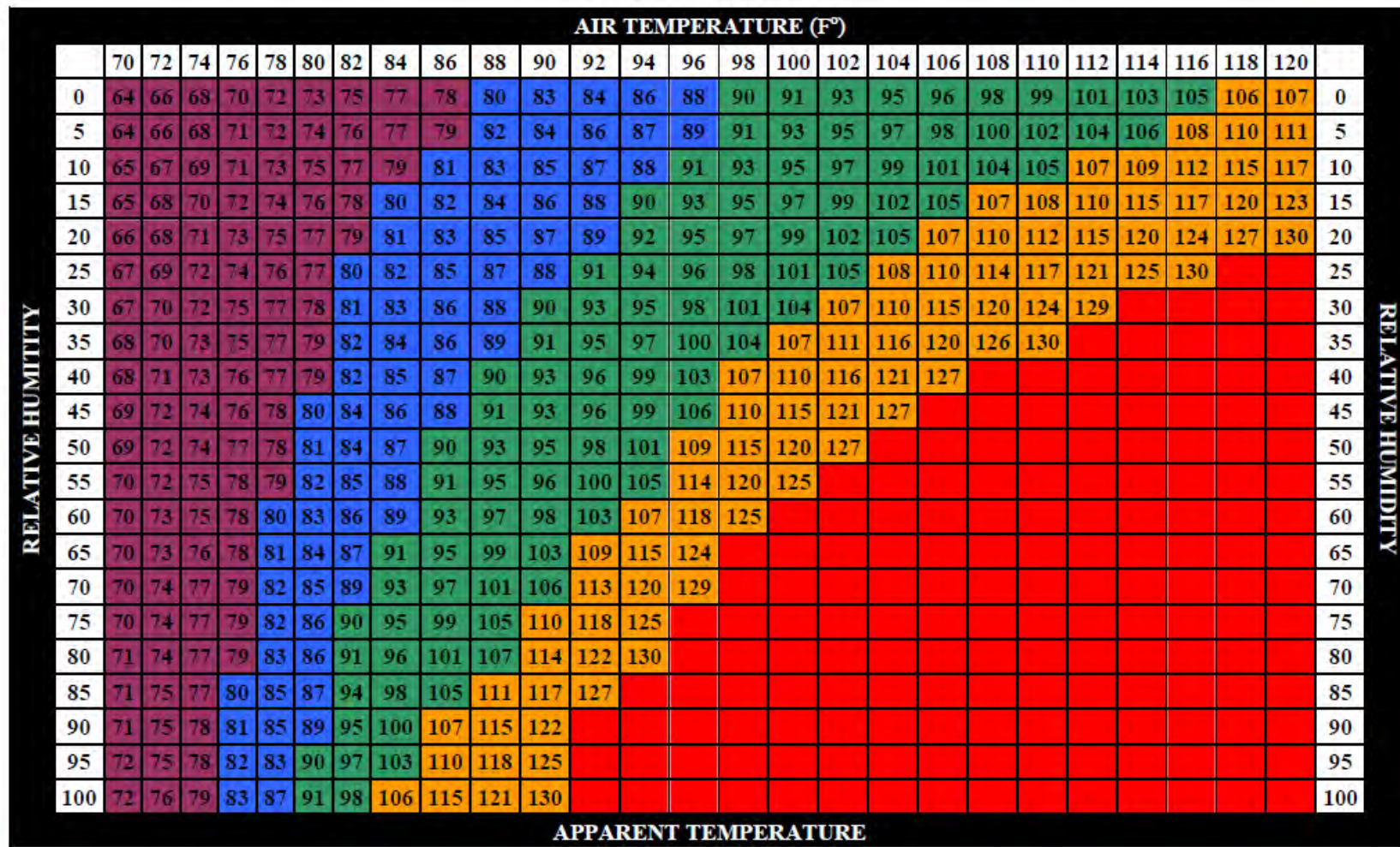

	Very Warm: fatigue possible with prolonged exposure.
	Hot: sunstroke, heat cramps, or heat exhaustion possible with prolonged exposure, exercise more fatiguing than usual
	Very Hot - Danger: sunstroke, heat cramps, or heat exhaustion likely with prolonged exposure
	Extreme Danger: heat/sunstroke, heat exhaustion highly likely with continued exposure
	Heat stroke imminent

Figure 9.1: Heat Stress Index

## 9.7 Site Safety Plan Information

The Site Safety Plan must address the safety and health hazards of each phase of the response operation including the requirements and procedures for employee protection. The Site Safety Plan should include the following:

- A safety and health risk and/or hazard analysis for each response task and operation. The risk/hazard analysis will include the following:
  - Location and approximate size of the response area.
  - Description and duration of the response activities to be performed.
  - Site topography and accessibility by air and roads.
  - Safety and health hazards expected to be encountered.
  - Exposure routes of expected contaminants and other risks, such as potential skin absorption and irritation, potential eye irritation, and concentrations that are immediately dangerous to life and health (IDLH).
  - Present status and capabilities of emergency response teams that would provide assistance to response personnel in the event of an emergency.
  - Health hazards involved or expected from contaminants present and their chemical and physical properties.
- Personal protective equipment to be used by employees during each of the response operations. The requirement for personal protective equipment will be based on the results of the preliminary site evaluation and the guidance provided in the Navy written safety and health program.
- Employee training requirements to assure compliance with the OSHA requirements. The training program section of the Navy written safety and health program should be used as guidance in preparation of this section.
- Medical surveillance requirements to ensure compliance with the OSHA requirements. The medical surveillance program section of the Navy written safety and health program should be used as guidance in preparation of this section.
- A schedule for and the types of air monitoring to be conducted for IDLH conditions, combustible gases, and other conditions that may cause death or serious harm.
- Methods of maintenance and calibration of monitoring and sampling equipment to be used.
- A schedule for and the types of environmental sampling techniques and instruments to be used.
- A site control program for protecting employees involved in response operations. The site control program will include a site map, an indication of the work zones, a description of the "buddy" system, site communications, emergency alert signals, standard operating procedures, or safe work practices, and identification of the nearest medical assistance.
- Standard operating procedures must minimize personnel and equipment contact with spill substances.
- Decontamination procedures that cover all phases of response operations must be developed. These procedures must be communicated to all response personnel and implemented before any response employees or equipment enters areas where they can be potentially exposed.
- An emergency response plan that is a separate section of the Site Safety Plan must be developed that covers:
  - Pre-emergency planning, personnel roles, lines of authority, and communication.

- Emergency recognition and prevention, safe distances, and places of refuge.
  - Site security and control evacuation routes and procedures.
  - Decontamination procedures (procedures that are not covered by the Site Safety Plan).
  - Emergency medical treatment and first aid.
  - Emergency alerting and response procedures.
  - Personal protective equipment and emergency equipment.
  - Response area topography, layout, and prevailing weather conditions.
  - Procedures for reporting incident to local, State, and Federal governmental agencies.
- A section covering the critique of a response and follow-up.
  - Confined space entry procedures.
  - A procedure for handling, labeling, and transporting drums and containers of recovered oil and oil-contaminated debris.

## **9.8 PPE Levels of Protection**

### **9.8.1 Ensemble Level**

PPE ensemble levels will be established by the Safety Officer.

### **9.8.2 General Signs/Symptoms That Indicate Potential Toxic Exposures**

- Sudden weight loss or change in appetite;
- Unusual fatigue or new sleeping difficulties;
- Unusual irritability;
- Skin rashes/allergies/sores;
- Hearing loss;
- Vision loss/problems;
- Changes in sense of smell;
- Shortness of breath/asthma/cough or sputum production;
- Chest pains;
- Nausea/vomiting/diarrhea/constipation;
- Weakness/tremors;
- Headaches;
- Personality changes.

## **9.9 Manifestations of Toxic Effects to Various Target Organs**

TARGET ORGAN: skin

MANIFESTATIONS: dermatitis, chloracne, skin cancer

CHEMICAL/PHYSICAL AGENT(S): Hydrocarbon solvents, chlorinated hydrocarbons (e.g., PCB), soap, dioxane, and alcohols

TARGET ORGAN: respiratory system

MANIFESTATIONS: acute pulmonary edema, pneumonitis, asthma, lung cancer

CHEMICAL/PHYSICAL AGENT(S): many forms of dusts, fumes, and vapors

TARGET ORGAN: cardiovascular system

MANIFESTATIONS: arrhythmias, angina



CHEMICAL/PHYSICAL AGENT(S): carbon monoxide, hydrogen sulfide, organophosphates, glues/glue-solvents, and temperature extremes

TARGET ORGAN: gastrointestinal system

MANIFESTATIONS: abdominal pain, nausea, vomiting, diarrhea, bloody stools, hepatic necrosis, hepatic cancer, hepatic fibrosis

CHEMICAL/PHYSICAL AGENT(S): hydrocarbon solvents, halogenated hydrocarbons, organic solvents, petroleum products, organophosphates, and corrosives

TARGET ORGAN: genitourinary system

MANIFESTATIONS: chronic renal disease, bladder cancer

CHEMICAL/PHYSICAL AGENT(S): halogenated hydrocarbons

TARGET ORGAN: nervous system

MANIFESTATIONS: headache, convulsions, coma, peripheral neuropathy

CHEMICAL/PHYSICAL AGENT(S): carbon monoxide, organophosphates, and organic solvents

TARGET ORGAN: auditory system

MANIFESTATIONS: temporary and permanent hearing loss/shift

CHEMICAL/PHYSICAL AGENT(S): loud noise

TARGET ORGAN: ophthalmic system

MANIFESTATIONS: eye irritation, cataracts

CHEMICAL/PHYSICAL AGENT(S): petroleum products and UV radiation

TARGET ORGAN: hematological system

MANIFESTATIONS: anemia, bleeding disorder, leukemia

CHEMICAL/PHYSICAL AGENT(S): benzene

### **9.10 Safety Data Sheets**

SDSs are provided with each delivery of fuel, specific to the manufacturer and production run of the product. On the absence of that specific data, example SDSs from past deliveries can be found in Appendix E.

THIS PAGE INTENTIONALLY LEFT BLANK

## 10.0 RESPONSE EQUIPMENT RESOURCES

The following sections detail the emergency response equipment that is available to the RHFSF in the event of a major incident from Navy, commercial, and State and Federal sources.

### 10.1 Navy Resources

#### 10.1.1 Firefighting and Crash Fire Rescue Equipment

TABLE 10.1: FIREFIGHTING & CRASH FIRE RESCUE EQUIPMENT					
Station	Call Sign	Year	Make	Type	Location
<b>FIRST LINE APPARATUS INVENTORY</b>					
1	E-101	6/2012	Pierce Saber	Pumper	JBPHH, Shipyard
	Tower 120	2007	Pierce	Tower / Platform	JBPHH, Shipyard
	HazMat-151	2004	Pierce	P-31(HazMat)	JBPHH, Shipyard
	Support 154	1996	Mercedes	Class"C"	JBPHH, Shipyard
2	E-102	6/2012	Pierce Saber	Pumper	JBPHH, Subase
	Medic-2	2011	Whl Coach	F-450/Type 1	JBPHH, Subase
3	E-103	6/2012	Pierce Saber	Pumper	Tripler AMC
4	E-104	2006	Pierce	Pumper	Ford Island
5	E-105	6/2012	Pierce Saber	Pumper	Manana, Pearl City
	Tanker-142	2006	Pierce	Tanker	Manana, Pearl City
6	E-106	2010	Pierce	Pumper	JBPHH
	Reserve-136	1994	KME	Pumper	JBPHH
	Medic 6	2011	Whl Coach	F-450/Type 1	JBPHH
	Tanker 143	1994	International	P-26(Water-Dist)	JBPHH
	New Tanker 143	2013	Pierce	Tanker	JBPHH
	ARFF-171	2005	OshKosh	T-1500	JBPHH
	ARFF-172	2006	OshKosh	T-1500	JBPHH
	Crash 175	1986	Oshkosh	P-19(FFGT)	JBPHH
	Crash 176	1994	Teledyne	P-23(FFGT)	JBPHH
	Crash 177	2006	Oshkosh	P-23(Striker)	JBPHH
7	Crash 178	1998	Oshkosh	Crash 3TK(FFGT)	JBPHH
	E-107	2006	Pierce	Pumper	NCTAMS, Wahiawa
8	Medic 7	2011	Whl Coach	F-450/Type 1	NCTAMS, Wahiawa
	E-108	2008	Pierce	Pumper	MCAS, Kaneohe
	New E-108	2013	Pierce	Pumper	MCAS, Kaneohe
	E-112	2010	Pierce	Pumper	MCAS, Kaneohe
	Medic-8	2008	Whl Coach	F-350/Type 1	MCAS, Kaneohe
	Brush 148	2011	Pierce	Large Wildland	MCAS, Kaneohe
	Hazmat 156	2002	Pierce	P-30(Med-Rescue)	JBPHH
	HazMat Trailer	2007	Wells Fargo	HazMat Response	MCAS, Kaneohe
9	E-109	2010	Pierce	Pumper	West Loch Annex
	Brush 145	2009	Ford	Medium Wildland	West Loch Annex
	E-110	2006	Pierce	Pumper	Helemano Mil Resv

<b>TABLE 10.1: FIREFIGHTING &amp; CRASH FIRE RESCUE EQUIPMENT</b>					
<b>Station</b>	<b>Call Sign</b>	<b>Year</b>	<b>Make</b>	<b>Type</b>	<b>Location</b>
<b>FIRST LINE APPARATUS INVENTORY (Cont.)</b>					
10	Brush 147	2009	Pierce	Large Wildland	Helemano Mil Resv
	E-114	2005	Pierce	Pumper	Wheeler AAF
14	Brush 144	2009	Ford	Medium Wildland	Wheeler AAF
	ARFF-173	2007	Oshkosh	T-1500	Wheeler AAF
	ARFF-174	2005	OshKosh	T-1500	Wheeler AAF
	Medic-14	2011	Whl Coach	F-450/Type 1	Wheeler AAF
15	E-115	2008	Pierce	Pumper	Schofield Barracks
	New E-115	2013	Pierce	Pumper	MCAS, Kaneohe
	Truck 119	2005	Pierce	105"	Schofield Barracks
	Tanker 141	2009	Pierce	Tanker	Schofield Barracks
	HazMat-152	1995	International	Medium HAZMAT	Schofield Barracks
	New HazMat-152	10/2013	Pierce	Heavy HAZMAT	Schofield Barracks
	HazMat-153	1994	Pierce	Small HAZMAT	Schofield Barracks
16	Brush 146	2009	Pierce	Large Wildland	Schofield Barracks
	E-116	2003	Pierce	Pumper	Camp H.M. Smith
	TAU-155	2009	Ford F-550	Twin Agent Unit	Camp H.M. Smith
<b>SPECIAL OPERATIONS/RESERVE/SUPPORT/GSA VEHICLES</b>					
1	Storage Trailer	2005	-	Equipment stowage	-
	Storage Trailer	-	-	Equipment stowage	-
	Storage Trailer	2004	Haulmark	Equipment stowage	-
	Special Ops 1	2003	MD288	Mass Decon trailer	-
6	MCI Trailer	-	Wells Fargo	-	-
	Foam Trailer	-	Stanly Emerg	-	-
	Mobile Air Trailer	-	Bauer	-	-
	Pump Test Trailer	2009	Wells Cargo	Pump Test	-
8	HazMat Trailer	-	Wells Fargo	-	-
	HazMat Trailer	2007	Wells Fargo	HazMat Response	-
4	Liberty 1	2006	-	Air Cart	-
WAAF	MAFT (cab)	2000	International	Trainer	-
	MAFT (trailer)	2000	-	Trainer	-
14	Liberty 2	2006	-	Air Cart	-
15	Special Ops 2	2003	-	Mass Decon Trailer	-
	Storage Trailer	2009	Wells Cargo	Equipment stowage	-
<b>RESERVE APPARATUS FLEET</b>					
15	Reserve 131 (101)	2003	Pierce	Pumper	-
10	Reserve 132 (110)	2003	Pierce	Pumper	-
8	Reserve 133 (103)	1997	KME	Pumper	-
6	Reserve 136 (107)	1994	KME	Pumper	-
NAVFAC	Truck 118	1994	Pierce	Tele-Squirt	-

TABLE 10.1: FIREFIGHTING & CRASH FIRE RESCUE EQUIPMENT					
Station	Call Sign	Year	Make	Type	Location
<b>COMMAND VEHICLES</b>					
HQ	District Chief- 1	2005	Ford	Sport Trac/Command	-
HQ	District Chief- 2	2005	Ford	Sport Trac/Command	-
1	Battalion Chief-4	2007	Chevy	Suburban/Command	-
8	Battalion Chief- 1	2012	Cherokee	SUV/Command	-
14	Battalion Chief- 2	2012	Cherokee	SUV/Command	-
HQTR	Battalion Chief Extra Vehicle	2012	Cherokee	SUV/Command	-
6	Battalion Chief- 3	-	Chevy	Suburban/Command	-
6	Fire Marshall	2006	Chevy	Trail Blazer	-
<b>GSA VEHICLES</b>					
-	FIRE 1	-	-	-	-
-	FIRE 2/3	-	-	-	-
-	Fire Marshal	-	-	-	-
-	SQUAD 161	2006	Ford	F-350	-
-	Supply	-	-	-	-
-	Supply F-350 (Blue)	2003	Dodge Ram	Pick up 7K LB	-
-	Training	-	-	-	-
-	Prevention 9	2003	Silverado	-	-
-	Prevention	2013	Ford Focus (Red)	-	-
-	Prevention	2013	Ford Focus (Red)	-	-
-	Prevention	2012	Chevy Malibu (Gray)	-	-
-	Prevention	2013	Ford Focus (Silver)	-	-
-	Prevention	2012	Chevy Malibu (Gray)	-	-
-	Prevention	2013	Ford Focus (Black)	-	-
-	Prevention	2012	Chevy Malibu (White)	-	-
-	Prevention	2012	Chevy Malibu (Silver)	-	-
-	Prevention	2013	Ford Focus (Red)	-	-
-	Prevention	2013	Ford Focus (Red)	-	-

**10.1.2 Heavy Equipment**

TABLE 10.2: HEAVY EQUIPMENT*			
Vehicle/Equipment Type	Year	ID #	Assignment Name
TRUCK CARGO PICKUP UP TO 8500 GVWR REGULAR CAB	2006	27766	NFH OPC741
TRUCK CARGO PICKUP UP TO 8500 GVWR REGULAR CAB	2014	29004	NFH OPC741
TRUCK CARGO PICKUP UP TO 8500 GVWR REGULAR CAB	2009	29005	NFH OPC741
TRUCK CARGO PICKUP COMPACT 4X2 UP TO 6100 GVWR EXTENDED CAB	2012	27771	NFH OPC741
TRUCK CARGO PICKUP COMPACT 4X2 UP TO 6100 GVWR EXTENDED CAB	2009	28174	NFH OPC741

<b>TABLE 10.2: HEAVY EQUIPMENT*</b>			
<b>Vehicle/Equipment Type</b>	<b>Year</b>	<b>ID #</b>	<b>Assignment Name</b>
TRUCK CARGO PICKUP COMPACT 4X2 UP TO 6100 GVWR EXTENDED CAB	2009	28175	NFH OPC741
TRUCK MULTISTOP STEP VAN 8501 - 13999 GVWR DUALY	2016	28176	NFH OPC741
TRUCK STAKE 21000 GVWR AND UP 12-22 FT BED EXTENDED CAB	2015	60034	NFH OPC741
TRUCK STAKE 21000 GVWR AND UP 12 - 22 FT BED REGULAR CAB HTG	2008	28177	NFH OPC741
TRUCK DUMP 5 CY 28000 GVWR	2009	28179	NFH OPC741
TRUCK DUMP 5 CY 28000 GVWR	1997	28180	NFH OPC741
TRUCK DUMP 10 CY 6X4 52000 GVWR	2000	28178	NFH OPC741
TRUCK DUMP 10 CY 6X4 52000 GVWR	1996	60028	NFH OPC741
TRUCK TRACTOR 6X4 43000 GVWR 70000 GCVWR	2016	29069	NFH OPC741
TRUCK TRACTOR 6 X 4 62000 GVWR 100000 GCVWR	1999	29075	NFH OPC741
TRUCK TRACTOR 6 X 4 62000 GVWR	2016	29068	NFH OPC741
TRUCK TRACTOR 6 X 4 62000 GVWR	2016	29070	NFH OPC741
TRUCK TRACTOR 6 X 4 62000 GVWR	2016	29071	NFH OPC741
TRUCK TRACTOR 6 X 4 62000 GVWR	2016	29073	NFH OPC741
TRUCK TRACTOR 6 X 4 62000 GVWR 100000 GCVWR	1990	29067	NFH OPC741
TRUCK TRACTOR 6 X 4 62000 GVWR 100000 GCVWR	2002	28950	NFH OPC741
TRUCK TRACTOR 6 X 4 62000 GVWR 100000 GCVWR	2002	28951	NFH OPC741
TRUCK TRACTOR 6 X 4 62000 GVWR 100000 GCVWR	2002	29076	NFH OPC741
TRUCK TRACTOR 6 X 4 62000 GVWR 100000 GCVWR	2002	29077	NFH OPC741
TRUCK MOUNTED OVERHEAD AERIAL SERVICE ARTICULATING NON OVER-CENTER TO 60 FT WORKING HEIGHT	2011	28953	NFH OPC741
TRUCK MOUNTED OVERHEAD AERIAL SERVICE ARTICULATING NON OVER-CENTER TO 60 FT WORKING HEIGHT	2016	28954	NFH OPC741
TRUCK WRECKER ROLLBACK	2016	29055	NFH OPC741
TRUCK TANK FUEL SERVICING 1 SYSTEM 1 TANK	2011	28956	NFH OPC741
TRUCK TANK FUEL SERVICING 1 SYSTEM 1 TANK	2014	28982	NFH OPC741
TRUCK TANK FUEL SERVICING 1 SYSTEM 1 TANK	2014	28983	NFH OPC741
SEMITRAILER STAKE 2-3 AXLE 20 TON 40-55 FT W/O STAKES	2006	27375	NFH OPC741
SEMITRAILER STAKE 2-3 AXLE 20 TON 40-55 FT W/O STAKES	2006	27992	NFH OPC741
SEMITRAILER STAKE 2-3 AXLE 20 TON 40-55 FT W/O STAKES	2002	28055	NFH OPC741
SEMITRAILER STAKE 2-3 AXLE 20 TON 40-55 FT W/O STAKES	2002	28181	NFH OPC741
SEMITRAILER STAKE 2-3 AXLE 20 TON 40-55 FT W/O STAKES	2006	29046	NFH OPC741
SEMITRAILER STAKE 2-3 AXLE 20 TON 40-55 FT W/O STAKES	2002	29047	NFH OPC741
SEMITRAILER DROP DECK 2 AXLE 20 TON	1988	29006	NFH OPC741
SEMITRAILER DROP DECK 2 AXLE 20 TON	1993	29050	NFH OPC741

<b>TABLE 10.2: HEAVY EQUIPMENT*</b>			
<b>Vehicle/Equipment Type</b>	<b>Year</b>	<b>ID #</b>	<b>Assignment Name</b>
SEMITRAILER LOWBED 2 AXLE 35 TON NONSTANDARD	1997	29052	NFH OPC741
SEMITRAILER LOWBED 3 AXLE 35 TON	2010	27769	NFH OPC741
SEMITRAILER LOWBED 3 AXLE 35 TON	2010	27770	NFH OPC741
SEMITRAILER LOWBED 3 AXLE 35 TON	1988	29053	NFH OPC741
SEMITRAILER LOWBED 3 AXLE 60 TON AND UP NONSTANDARD	2016	27767	NFH OPC741
SEMITRAILER LOWBED 3 AXLE 60 TON AND UP NONSTANDARD	1999	29054	NFH OPC741
TRAILER HYDRAULIC ELEVATING BODY NONSTANDARD	1992	29056	NFH OPC741
TRAILER LOWBED TRANSPORTER 18001 GVWR AND UP TRAVELING AXLE	2016	29051	NFH OPC741
TRAILER LOWBED TRANSPORTER 18001 GVWR AND UP TRAVELING AXLE	2016	29057	NFH OPC741
SEMITRAILER DEMOLITION REAR DUMP 34 CY	2010	27768	NFH OPC741
SEMITRAILER DEMOLITION REAR DUMP 34 CY	2017	29007	NFH OPC741
SEMITRAILER DEMOLITION REAR DUMP 34 CY	1992	29009	NFH OPC741
SEMITRAILER DEMOLITION REAR DUMP 34 CY	2001	29059	NFH OPC741
SEMITRAILER DEMOLITION REAR DUMP 34 CY	2002	29060	NFH OPC741
SEMITRAILER DEMOLITION REAR DUMP 34 CY	2002	29061	NFH OPC741
SEMITRAILER DEMOLITION REAR DUMP 34 CY	2001	29063	NFH OPC741
SEMITRAILER DEMOLITION REAR DUMP 34 CY	1995	29064	NFH OPC741
SEMITRAILER DEMOLITION REAR DUMP 34 CY	2017	29065	NFH OPC741
TRAILER LOWBED TILT DECK TANDEM AXLE UP TO 60 TON	2015	29010	NFH OPC741
DISTRIBUTER WATER TRUCK/TRAILER COMMERCIAL NONSTANDARD	2015	27990	NFH OPC741
DISTRIBUTER WATER TRUCK/TRAILER COMMERCIAL NONSTANDARD	2015	28171	NFH OPC741
EXCAVATOR CRAWLER MOUNTED HYDRAULIC OPERATED NONSTANDARD	1998	28984	NFH OPC741
EXCAVATOR CRAWLER MOUNTED HYDRAULIC OPERATED NONSTANDARD	2002	28985	NFH OPC741
EXCAVATOR CRAWLER MOUNTED HYDRAULIC OPERATED NONSTANDARD	2002	28986	NFH OPC741
LOADER SCOOP TRACK 1.75 CY BUCKET W/ TEETH	1998	28987	NFH OPC741
LOADER SCOOP TRACK 1.75 CY BUCKET W/ TEETH	2002	28988	NFH OPC741
LOADER SCOOP WHEEL MOUNTED 4X4 NONSTANDARD	2010	27492	NFH OPC741
LOADER SKID STEER NONSTANDARD	1987	27493	NFH OPC741
LOADER SCOOP WHEEL MOUNTED 1.5 CY GP 85 HP CAB	1991	28990	NFH OPC741
ROLLER ROAD 2 AXLE TANDEM 3 - 6 TON	1988	28991	NFH OPC741
ROLLER ROAD 2 AXLE TANDEM 3 - 6 TON	2013	28992	NFH OPC741
TRACTOR WHEELED INDUSTRIAL 4 X 2 60 HP MIN LDR 1 BUCKET BACKHOE	1993	28993	NFH OPC741
TRACTOR WHEELED INDUSTRIAL 4 X 2 60 HP MIN LDR 1 BUCKET BACKHOE	1993	28994	NFH OPC741
TRACTOR WHEELED INDUSTRIAL 4 X 2 60 HP MIN LDR 1 BUCKET BACKHOE	2017	28995	NFH OPC741

<b>TABLE 10.2: HEAVY EQUIPMENT*</b>			
<b>Vehicle/Equipment Type</b>	<b>Year</b>	<b>ID #</b>	<b>Assignment Name</b>
TRACTOR WHEELED INDUSTRIAL 4 X 2 60 HP MIN LDR 1 BUCKET BACKHOE	2017	28996	NFH OPC741
TRACTOR WHEELED INDUSTRIAL 4 X 4 90 HP MIN LDR 1.5 BUCKET BACKHOE	2017	28997	NFH OPC741
TRACTOR WHEELED INDUSTRIAL 4 X 4 90 HP MIN LDR 1.5 BUCKET BACKHOE	1995	28998	NFH OPC741
CLEANER SEWAGE/WASTE COLLECTION 1300 GALLON	2016	29001	NFH OPC741
CLEANER SEWAGE/WASTE COLLECTION 1300 GALLON	2016	29002	NFH OPC741
CLEANER SEWAGE/WASTE COLLECTION 1300 GALLON	2011	29003	NFH OPC741
SWEeper ROTARY SELF-PROPELLED WHEEL MOUNTED NONSTANDARD	2007	28999	NFH OPC741
SWEeper ROTARY SELF-PROPELLED WHEEL MOUNTED NONSTANDARD	2010	29000	NFH OPC741

\*NAVFAC HI Transportation

### 10.1.3 Sorbents and Spill Kits

<b>TABLE 10.3: SORBENTS AND SPILL KITS</b>			
<b>Item</b>	<b>Location</b>	<b>Unit</b>	<b>In Stock</b>
<b>PORT OPERATIONS/FRT</b>			
Absorbent Pads	Ford Island Building 3	100 Pads per Bale	30
Absorbent Sweeps (19' x 100')	“ “	1 Sweep per Bale	62
Absorbent Boom (8" x 10")	“ “	4 Per Bag	32
Various Spill Kits	“ “	Kit	Multiple
Organic Absorbent Beads	“ “	Box	Multiple
Particulate Absorbent	“ “	Bag	Multiple
Dragnet Pom Poms	“ “	Unknown	Multiple
Filter Belts for Skimmer (Fine Foam)	“ “	Unknown	Multiple
<b>FEDERAL FIRE DEPARTMENT</b>			
Granular Absorbent Floor Dri Brand, Size 24qts.	Station 1	Bag	15
Absorbent Pads, Size 15" x 15"	“ “	50/Box	8
2.5 Rolls Absorbent Boom	Station 6	-	-
500 Absorbent Pads	“ “	-	-
Granular Absorbent, Size 20 Gallons	Station 8	Overpack	1
Spill Kits For Oils, Coolants, Solvents	Various Stations and Vehicles	Kit	Multiple
Spill Kits for Acids, Caustics, Strong Solvents	“ “	Kit	Multiple
Spill Kits for Acid and Caustics	“ “	Kit	Multiple
Spill Kit for Non-Aggressive Fluids	“ “	Kit	Multiple
Spill Kit for Aggressive Fluids	“ “	Kit	Multiple



<b>TABLE 10.3: SORBENTS AND SPILL KITS</b>			
<b>Item</b>	<b>Location</b>	<b>Unit</b>	<b>In Stock</b>
<b>FLCPH FUEL DEPARTMENT</b>			
Absorbent Diapers	Building 1757	Bale	14
Absorbent Diapers	“ “	Box	2
Large Sausage Boom (Orange)	“ “	Boom	13
Medium Sausage Boom (White)	“ “	Boom	11
Small Sausage Boom (Blue)	“ “	Boom	35
Small Sausage Boom (Blue)	“ “	Box	1
Absorbent Diapers	“ “	100 per Bale	4
Small Napkin Oil Absorbents	“ “	Pack	3
Sausage Boom	“ “	Boom	4
Absorbent Diapers	“ “	100 per Pack	5
10” Sausage Boom	“ “	Boom	6
Oil Pig Socks	Bldg 2125	Bundle	2
Medium Sausage Boom (White)	“ “	Bag	2
Various Spill Kits	Various Locations	Kit	Multiple
<b>NAVFAC HI</b>			
“Speedy Dry” Absorbent	Waste Treatment Plant	Bag	Multiple
Sorbent Pillows	“ “	Bag	Multiple
Various Spill Kits	“ “	Kit	Multiple

10.1.4 Vacuum Trucks

TABLE 10.4: VACUUM TRUCKS							
Topic		Truck Type	Truck Type	Truck Type	Truck Type	Truck Type	Truck Type
NUMBER	ON HAND	1	1	3	1	3	1
MANUFACTURER	BRAND	Isometrics	Isometrics	International	Freightliner	Freightliner	Freightliner
	MODEL	Unk	Unk	Unk	Unk	Unk	Unk
	YEAR	2009	2006	Unk	Unk	Unk	Unk
PICK-UP HEAD TYPE (Manta, weir, etc.)		Weir/Hose Nozzles	Weir/Hose Nozzles	Weir/Hose Nozzles	Weir/Hose Nozzles	Weir/Hose Nozzles	Weir/Hose Nozzles
RECOVERY RATES	NOMINAL (gals/min)	80	80	100	80	80	80
	DE-RATED DAILY (gals/day)	23,040	23,040	3 @ 28,800 Each 86,400 Total	23,040	3 @ 23,040 69,120	23,040
	“ “ (bbls/day)	549	549	3 @ 686 Each 2,058 Total	549	3 @ 549 1,647	549
	TANK SIZE (gals)	2,000	2,000	2,000 Each	2,000	2,000 Each	4,000
MOBILIZATION	POINT OF CONTACT	Port Operations FRT 474-6262 (24 hr.)	Port Operations FRT 474-6262 (24 hr.)	NAVSUP FLCPH 473-7801	NAVFAC HI Emerg. Service Desk 449-3100	NAVFAC HI Emerg. Service Desk 449-3100	NAVFAC HI Emerg. Service Desk 449-3100
	STORAGE LOCATION	Building 3, Ford Island	Building 3, Ford Island	Fuel Department, Bldg 1757	Hickam Air Field Bldg 2125	BOWTS Facility Bldg 1910	BOWTS Facility Bldg 1910
	CREW NEEDED	1	1	1	1	1	1
	TIME (hrs) (Request on the road)	10 mins	10 mins	10 mins	10 mins	10 mins	10 mins
TOTAL DE-RATED DAILY RECOVERY AVAILBALE ON-SITE FROM VACUUM TRUCKS: 247,680 gals/day (5,897 bbls/day)							

## 10.1.5 Skimmers

<b>TABLE 10.5: SKIMMERS</b>			
<b>VESSELS SKIMMERS</b>			
	<b>Topic</b>	<b>Type</b>	<b>Type</b>
NUMBER	ON HAND	1	1
MANUFACTURER	BRAND	Kvichak Marine	Kvichak Marine
	MODEL	30' Skimmer Boat	28' Skimmer Boat
	BOAT ID	SK-1	SK-2
	YEAR	2012	2005
TYPE	OPERATING PRINCIPLE	KVICHAK 1 foot wide filterbelt module	KVICHAK 1 foot wide filterbelt module
	MANNED OR UNMANNED	Manned	Manned
RECOVERY RATES	NOMINAL (gals/min)	80	80
	DE-RATED DAILY (gals/day)	23,040	23,040
	“ “ (bbls/day)	549	549
	BUILT-IN STORAGE (gals)	1,000	1,000
	BLADDER STORAGE (gals)	0	0
MOBILIZATION	POINT OF CONTACT	Port Operations FRT 474-6262 (24 hr.)	Port Operations FRT 474-6262 (24 hr.)
	STORAGE LOCATIONS	Building 3, Ford Island	Building 3, Ford Island
	TRANSPORTATION NEEDED	Skimmer has Trailer	Skimmer has Trailer
	LAUNCH SITE (S)	Building 3, Ford Island	Building 3, Ford Island
	CREW NEEDED	2	2
	TIME (hrs) (Request on water)	<1	<1
TOTAL DE-RATED DAILY RECOVERY AVAILBALE ON-SITE FROM SKIMMERS: 46,080 gals/day (954 bbls/day)			
<b>PORTABLE SKIMMERS</b>			
<b>Manufacturer</b>	<b>Brand</b>	<b>Location</b>	<b>On Hand</b>
Douglas Environmental	Skim-Pac Skimmer	Building 3, Ford Island	2
Douglas Environmental	Skim-Pac Skimmer	Building 3, Ford Island	1
Douglas Environmental	Skim-Pac Skimmer	Building 3, Ford Island	1
Applied Fabric	Harbor Buster Towable Skimmer	Building 3, Ford Island	1
Unknown	Duckbill Skimmer	Fuel Department, Bldg 1757	2
Unknown	Skimmer	Fuel Department, Bldg 1757	2
Unknown	Duckbill Skimmer	Hickam Spill Cart, Bldg 2125	1
Douglas Environmental	Skim-Pac Skimmer	Hickam Spill Cart, Bldg 2125	1

## 10.1.6 Response Vessels

TABLE 10.6: RESPONSE VESSELS				
Equipment	How Many	Type	Location	Op. Status
BOOM-DEPLOYING BOATS	1	2006 Northwind 21' Utility Boat (FRT-1)	FRT Dock, Ford Island	Functional
	1	2007 Workskiff 21' Utility Boat (FRT-2)	“ “	“ “
	1	2006 Northwind 21' Utility Boat (FRT-3)	“ “	“ “
	1	2007 Workskiff 21' Utility Boat (FRT-4)	“ “	“ “
	1	1996 Searc Marine 30' Platform Boat (RRP-1)	“ “	“ “
	1	2006 Almar 30' Platform Boat (RRP-3)	“ “	“ “
	1	30' Platform Boat (RRP-4)	“ “	“ “
OTHER BOATS	4	Work Boats	Port Operations	Functional
	4	Tugs	“ “	“ “
	1	Pilot Boat	“ “	“ “
	1	Personnel Boat	“ “	“ “
	1	12' Boat	“ “	“ “

## 10.1.7 Boom

TABLE 10.7: BOOM				
Class	Skirt Size	Point of Contacty	Amount (ft)	Location
RESPONSE BOOM (STORAGE AND IN-WATER)				
Class II	24 inch	Port Operations FRT 474-6262 (24 hr.)	29,200	Varies
RESPONSE BOOM ON REELS				
Class II	24 inch	Port Operations FRT 474-6262 (24 hr.)	5,000	5 Reels at: Kilo 1, Kilo 9, Sierra 4, Lima Landing, and Hickam Harbor (1,000 ft / reel)
<b>Total Response Boom: 34,200 Feet</b>				
PERMANENT (HARD) BOOM IN WATER				
Perma-Boom	24 inch	Port Operations FRT 474-6262 (24 hr.)	31,500	Varies
PERMANENT (HARD) BOOM ON REELS				
Perma-Boom	24 inch	Port Operations FRT 474-6262 (24 hr.)	400	Arizona Visitor Center where Halawa Stream empties into Pearl Harbor
PERMANENT (HARD) BOOM IN STORAGE				
Perma-Boom	24 inch	Port Operations FRT 474-6262 (24 hr.)	4,600	Building 174
<b>Total Perma-Boom: 36,500 Feet</b>				

### 10.1.8 Temporary Waste Oil Storage

TABLE 10.8: TEMPORARY WASTE OIL STORAGE		
Equipment	Capacity	Location / POC / Telephone
<b>BULK STORAGE EQUIPMENT FOR RECOVERED OIL</b>		
Ship Waste Off-Loading Barge (SWOB) # 12 and 48	2 @ 70,000 gals	Waterfront Operations Officer 474-6262
Yard Oiler Navy (YON) Barge # 328, 335, 336	#328 @ 500,000 gals #335 @ 300,000 gals #336 @ 300,000 gals	Fuel Department 473-7833 or 690-0115 (24 hours)
YON Barge # 281	300,000 gals	Waterfront Operations Officer 474-6262
NAVSUP FLCPH Upper Tank Farm Bulk Storage Tanks	Approximately 6,300,000 gals each	Fuel Deptment 473-7833 or 690-0115 (24 hours)
NAVSUP FLCPH FORFAC Bulk Storage Tanks B-1 and B-2	378,000 gals each	Fuel Deptment 473-7833 or 690-0115 (24 hours)
Oil Storage Bladders	1 @ 290,000 gals 2 @ 136,000 gals 2 @ 26,000 gals 1 @ 21,000 gals 6 @ 500 gals	Navy SUPSALV Hawaii ESSM Base (As of November 2017) (202) 781-1731, Option #2 (during work hours) (202) 781-3889 (Duty Officer, after hours)
<b>STORAGE EQUIPMENT FOR CONTAMINATED WASTE/HAZARDOUS WASTES/RESPONSE WASTES AND DEBRIS</b>		
Drums	Multiple @ 55 gal	NAVFAC HI Environmental Services 471-1171
Dumpsters	Multiple @ Variable	NAVFAC HI Environmental Services 471-1171

\*Storage capacity if empty and available. Storage systems may not be available.

## 10.2 Response Personnel

### 10.2.1 Immediate Response Teams

The Immediate Response Team for OHS spills on land is the FFD. For oil spills on water, the Immediate Response Team is the FRT, which is a contractor run, on-water spill response team based on Ford Island. The Immediate Response Teams are the first responders to OHS spills. Table 10.9 lists the key personnel and contact information for the FRT.

TABLE 10.9: FACILITY RESPONSE TEAM						
Name	Day Phone	24 Hr Phone	Response Time (Min)	Response Job	Training Type	Training Date
Operations Manager	472-9942	472-9942	< 30 min	Operations Leader	ICS/ 40-HOUR HAZWOPER	See training records
23 Personnel	Same	Same	< 30 min	Skimmer/ Boat Operator	40-HOUR HAZWOPER	See training records
5 Personnel	Same	Same	< 30 min	Decontamination	40-HOUR HAZWOPER	See training records
4 Personnel	Same	Same	< 30 min	Vacuum Truck	40-HOUR HAZWOPER	See training records
12 Personnel	Same	Same	< 30 min	As Directed	40-HOUR HAZWOPER	See training records
NOTE: The FRT is manned 24-hours/day and operates out of Building 3 on Ford Island.						

### 10.2.2 Spill Management Team

The Navy policy is to use the Incident Command System (ICS)/Unified Command (UC) for structuring Navy spill response management organizations. These are effective command and control systems specifically designed to be flexible in order to accommodate small to worst-case spills and the changing conditions and dynamics that often occur in a spill response. In addition, the ICS and UCS structures facilitate coordination with regulatory agency personnel, contractors, and public organizations or groups.

The CNRH SMT takes over control from the Fire Department once the emergency phase of the spill is over. The composition of the team, using the ICS structure, will vary depending on the circumstances and scope of the spill as noted earlier. The SMT's structure and positions are discussed in Appendix B of the CNRH Integrated Contingency Plan (ICP).

### 10.3 Navy Supervisor of Salvage (SUPSALV)

Naval Sea Systems Command (NAVSEA), through the SUPSALV, Code 00C, maintains the largest inventory of pollution response equipment anywhere in the Navy. This equipment is suitable for offshore and salvage-related pollution incidents and is located at four Emergency Ship Salvage Material (ESSM) Warehouses around the country for rapid deployment to pollution sites. Table 10.10 provides an inventory of SUPSALV pollution control equipment along with its location. Along with the equipment, SUPSALV provides trained contractor personnel to operate equipment, and experienced staff operations personnel to assist the NOSC in key decision-making.

TABLE 10.10: NAVY SUPSALV OIL SPILL RESPONSE EQUIPMENT						
SKIMMER SYSTEMS						
System ID	System	EDRC	ESSM VA	ESSM CA	ESSM AK	ESSM HI
		bbls/day	#	#	#	#
P16100	Modular Vessel Skimmer	3,929	3	4	2	2
P16200	Salvage Support Skimmer	1,056	2	3	0	2
P16300	High Speed Skimmer VOSS	1,510	10	1	1	1
P16310	Class XI VOSS	3,929	1	0	1	0
P16400	Vessel Skimmer	3,929	5	4	1	1
P16500	Heavy Debris Recovery System	2,757	1	1	2	0
P16700	Inland Support Skimmer	651	0	0	2	0
P18100	Vacuum Pump Skimmer	2,400	1	0	0	0
<b>Total EDRC bbls/day</b>			57,730	38,867	24,042	15,409
BOOM SYSTEMS						
System ID	System	Boom (ft)	ESSM VA	ESSM CA	ESSM AK	ESSM HI
			#	#	#	#
P16200	Salvage Skim Van	1,000	2	3	0	2
P19070	Oil Containment Boom System, 18" Harbor Boom	2,000	9	8	3	0
P19080	Oil Containment Boom System, USS-18 " IFL Boom	4,000	3	2	5	2

<b>TABLE 10.10: SUPSALV OIL SPILL RESPONSE EQUIPMENT</b>						
<b>BOOM SYSTEMS (Cont.)</b>						
System ID	System	Boom (ft)	ESSM VA	ESSM CA	ESSM AK	ESSM HI
			#	#	#	#
P19090	Oil Containment Boom System, USS-26" Boom	3,200	5	3	3	4
P19100	Oil Containment Boom System (42")	2,000	16	10	7	8
<b>Total Booming (ft)</b>			80,000	56,600	49,600	38,800
<b>TEMPORARY STORAGE</b>						
System ID	System	TSC (bbls)	ESSM VA	ESSM CA	ESSM AK	ESSM HI
			#	#	#	#
P14200	290K Gallon Bladder	6,905	0	0	1	1
P14100	136K Gallon Bladder	3,238	5	4	2	2
P14300	50K Gallon Bladder	1,190	1	2	0	0
P14300	26K Gallon Bladder	619	1	0	0	0
P16100	26K Gallon Bladder	619	1	2	2	2
P14300	21K Gallon Bladder	500	14	0	1	1
P16100	21K Gallon Bladder	500	2	2	0	0
P16400	21K Gallon Bladder	500	5	4	2	0
P16700	1,500 Gallon Bladder	36	0	0	2	0
P16200	500 Gallon Bladder	12	6	9	0	6
P16500	500 Gallon Bladder	12	1	1	2	0
<b>Total TSC bbls</b>			29,202	19,690	16,215	15,191

### 10.3.1 Contact Information

For spills exceeding CNRH's response capabilities (Tier 2 & 3 spills) SUPSALV can be contacted at 202-781-1731, extension 2. The numbers will connect to NAVSEA personnel who will in turn notify SUPSALV. SUPSALV can respond from their ESSM base at Bishop Point in JBPHH within 6 hours and within 36 and 60 hours from their West Coast and East Coast locations, respectively.

Equipment requests should be initiated from SUPSALV's CAC enabled website - <https://secure.supsalv.org>. The ESSM Equipment Request link can be found on the left side menu. If commands are unable to access the CAC enabled site, they may use the following PDF. [[Request Form PDF](#)] (preferred method) or by naval message, official e-mail, or by FAX using sample format provided below. Additional U.S. Navy guidance is available on the instructions section of the 00C2 Salvage Publications section of SUPSALV's CAC enabled website.

Requests should be forwarded to:

Email: [essmmanager@supsalv.org](mailto:essmmanager@supsalv.org)

Phone: 202-781-1731 extension 2, or

Fax: 202-781-4588

**Navy Request for ESSM Equipment - Required Content**

-----  
From:

To: Naval Sea Systems Command (SEA00C) (ESSMManager@supsalv.org)

Subj: REQUEST FOR ESSM EQUIPMENT

Requesting Activity:

Equipment Required:

Justification for Request:

Required Delivery Date:

Anticipated Return Date:

Shipping Instructions:

Provide Shipping TAC or TCN number or appropriate line of accounting.

Provide appropriate line of accounting to cover repair or replacement of lost or damaged equipment/components.

Requestor, Technical P.O.C. Name: Command: Title: Telephone: Fax: Email:

Financial P.O.C. Name: Command: Title: Telephone: Fax: Email:

Additional Information:  
-----

**10.3.2 Authority to Utilize U.S. Navy SUPSALV**

The below letter from the Department of Navy, dated January 10, 2014, authorizes any DOD facility to list in its FRP/ICP the spill response resources owned and managed by U.S. Navy SUPSALV in order to meet their OPA 90 requirements.





DEPARTMENT OF THE NAVY  
NAVAL SEA SYSTEMS COMMAND  
1333 ISAAC HULL AVENUE SE  
WASHINGTON NAVY YARD DC 20376

IN REPLY TO:

5090  
Ser 00C25/2002  
10 JAN 2014

From: Commander, Naval Sea Systems Command (00C)

Subj: AUTHORITY TO UTILIZE U.S. NAVY SUPERVISOR OF SALVAGE (SUPSALV) OIL SPILL RESPONSE EQUIPMENT

Ref: (a) SUPSALV Ltr Ser 00C25/2016 of 23 May 2008  
(b) Oil Pollution Act of 1990 (OPA 90),  
(c) OPNAVINST 5090.1(series), Environmental Readiness Program Manual  
(d) 40CFR300, National Oil and Hazardous Substances Pollution Contingency Plan

Encl: (1) USCG Tiered Response Requirements, excerpts from 33CFR154, 33CFR155, and 40CFR112  
(2) SUPSALV Equipment Capabilities

1. This letter replaces and updates reference (a), including the addition of contract aerial surveillance and dispersant capabilities newly required by reference (b). Pursuant to reference (b), facilities handling threshold quantities of oil are required to maintain Facility Response Plans (FRPs), addressing a full range of spill response scenarios. For each scenario, response equipment and trained personnel are required to respond with a defined capability and within certain time requirements. This letter authorizes any DoD facility to list in its FRP the spill response resources owned and managed by the U.S. Navy Supervisor of Salvage (SUPSALV) to the extent they meet the time and capability requirements of the mandated scenarios.

2. In accordance with reference (c), the Office of the Supervisor of Salvage (SUPSALV) of the Naval Sea Systems Command (NAVSEA Code 00C) is responsible for providing technical support and resources to the Navy Fleet and shore establishment under the oil and hazardous substance (OHS) spill response program. Reference (d) discusses SUPSALV capability to provide spill response assistance, upon request of the On Scene Coordinator (OSC), to other federal agencies. Under its Emergency Ship Salvage Material (ESSM) System, SUPSALV maintains an extensive inventory of centrally-located, open-ocean and catastrophic (on land or afloat) spill response equipment that is strategically

Subj: AUTHORITY TO UTILIZE U.S. NAVY SUPERVISOR OF SALVAGE  
(SUPSALV) OIL SPILL RESPONSE EQUIPMENT

pre-positioned to provide rapid response to Navy spills. This equipment, with operating personnel, is available for response to any DoD component (and any other federal agency, if requested by the OSC) in the event of large oil spills beyond the capabilities of the facility's locally available spill response assets. Access to this equipment is on an actual cost-reimbursable basis for deployment - there is no retainer charge. SUPSALV spill response assets in the United States are located in Williamsburg, VA, Port Hueneme, CA, Pearl Harbor, HI, and Anchorage, AK. SUPSALV military and civilian technical specialists are available around-the-clock to provide further information on available resources and to assist with on-scene emergency response by providing technical assistance and/or coordinating the deployment and management of SUPSALV contractor and ESSM resources as required by the Navy/Federal customer.

3. SUPSALV's equipment inventory is capable of rapid deployment by either air or truck. The gear has been specifically designed to be self-supporting and capable of operating in remote locations if need be. This capability allows SUPSALV to operate in both inland and at-sea environments. SUPSALV personnel, equipment, and technical specialists have extensive operational experience and meet US Coast Guard Oil Spill Removal Organization (OSRO) maintenance, exercise and training requirements.

4. Regulatory agencies have established a combination of required response resources and the times within which the resources must arrive on scene for various spill scenarios, including Worst Case Discharges (WCD). Enclosure (1) provides a summary of WCD Tiered requirements as described in 40CFR112, 33CFR154, and 33CFR155. The geographic dispersion of SUPSALV's Emergency Ship Salvage Material (ESSM) bases allows SUPSALV flexibility in pulling equipment from the closest ESSM site or support contractor site, or by cascading equipment from other bases. This can greatly expedite response times and increase the amount of available assets. Response from the ESSM base in Williamsburg generally meets WCD Tiers 2 and 3 time requirements for the Gulf Coast, East Coast, and Great Lakes, and Tier 3 requirements on the West Coast (except for the Puget Sound area). Response from the ESSM base in Port Hueneme generally meets the WCD Tiers 2 and 3 time requirements for the West Coast and Tier 3 requirements on the Gulf Coast, East Coast, and Great Lakes. This response capability allows most DOD facilities and afloat entities to list SUPSALV as an appropriate responder in their spill contingency plans (such as Facility Response Plans,

Subj: AUTHORITY TO UTILIZE U.S. NAVY SUPERVISOR OF SALVAGE  
(SUPSALV) OIL SPILL RESPONSE EQUIPMENT

Spill Contingency Plans, and Vessel Response Plans) in order to meet government mandated response requirements (facilities) or voluntary compliance (public vessels). To determine a predicted response time for any specific facility, please call the point of contact at SUPSALV listed below.

5. The SUPSALV web link, [www.supsalv.org](http://www.supsalv.org), may be useful during updates of Oil and Hazardous Substances (OHS) spill contingency plans for Navy and other Department of Defense facilities that cite SUPSALV as a spill response organization. Planning information can be found under the "00C25 Environmental" tab of this website and specifically under "Equipment." General information and equipment descriptions are available as well as the following resources:

- "ESSM Pollution Response Equipment Inventory (By location)" offers users an updated table listing the equipment available at each ESSM location.
- "SUPSALV Contingency Planning" offers users pre-calculated Effective Daily Recovery Capacity (EDRC), Temporary Storage Capacity (TSC) and Feet of Boom for all SUPSALV equipment.
- "ESSM Equipment Request Procedures" provide guidelines for requesting SUPSALV assistance (such as request procedures, funding requirements, and a sample request message).

Enclosure (2) lists equipment capabilities using OPA 90 calculations. These figures may be used in determining equipment requirements necessary to meet worst case discharge (WCD) scenarios. Further descriptions of the equipment capabilities can be provided upon request. Each command remains responsible to ensure that they can meet the tiered response requirement criteria outlined in the regulations as applied to their facility.

6. Addressees desiring to include SUPSALV response assets in their contingency planning, or desiring further information, should coordinate with the points of contact listed in this paragraph. Addressees are further requested to distribute information regarding SUPSALV's response resources to their subordinate commands. Questions concerning access to SUPSALV resources can be addressed to the SUPSALV Operations and Ocean Engineering Division at (202) 781-1731, extension 2. Points of contact are Mr. Mike Herb for salvage matters and Mr. Kemp Skudin for pollution response matters.

Subj: AUTHORITY TO UTILIZE U.S. NAVY SUPERVISOR OF SALVAGE  
(SUPSALV) OIL SPILL RESPONSE EQUIPMENT

For after-hours emergencies, contact the NAVSEA Duty Officer at  
(202) 781-3889.



Mark M Matthews  
Supervisor of Salvage and Diving,  
Director of Ocean Engineering, USN

DISTRIBUTION:

National Response Team  
Regional Response Teams  
National Air and Space Administration  
National Oceanic and Atmospheric Administration  
National Science Foundation  
USCG District Offices (dr)  
USCG Sector Commands  
U.S. Maritime Administration (MAR-610.1)  
USNORTHCOM (J3, J5)  
Deputy Commandant of the Marine Corps (Installations and  
Logistics)  
HQ USAF (AF/A7C, AF/A7CV)  
HQ Air Force Civil Engineer Support Agency (AFCESA)  
Air Force Petroleum Agency (AFPA)  
HQ Air National Guard (ANG)  
Army Corps of Engineers  
ATZF-CSS Marine Safety Office (Dept of the Army Watercraft  
Fleet)  
ASAR 63<sup>rd</sup> RSC/99<sup>th</sup> RRC (Dept of the Army Reserve Watercraft Fleet)  
COMSC (N732)  
COMSUBFOR (N451A))  
NAVFAC LANT (EV12)  
NAVFAC PAC (EV1)  
NAVFAC EXWCNAVFAC MIDLANT (N45, EV1)  
NAVFAC SOUTHEAST (N45, EV1)  
NAVFAC MIDWEST (N45, EV1)  
NAVFAC SOUTHWEST (N45, EV1)  
NAVFAC NORTHWEST (N45, EV1)  
NAVFAC WASH (N45, EV1)  
NAVFAC HAWAII (N45, EV1))  
NAVFAC MARIANAS (N40, EV1)

Copy to:

USCG Headquarters (CG-533)  
USCG Marine Safety Center  
Federal Emergency Management Agency

Subj: AUTHORITY TO UTILIZE U.S. NAVY SUPERVISOR OF SALVAGE  
(SUPSALV) OIL SPILL RESPONSE EQUIPMENT

Environmental Protection Agency  
Office of the Secretary of Defense (Joint Director of Military  
Support (JDOMS))  
Missile Defense Agency (SBX-1 Program)  
Defense Logistics Agency- Energy  
OPNAV (N452)  
COMPACFLT (N01CE15, N3, N4, N4655)  
CUSFFC (N3, N43, N7)  
COMUSNAVCENT (N3, N44, N5)  
COMUSNAVEUR, COMUSNAVAF (N3, N5)CNIC (N45)  
NAVFACHQ (CWA Program Administrator)  
NAVFAC FAREAST (EV1)  
COMNAVREG MIDLANT (N451)  
COMNAVREG SOUTHEAST (N45)  
COMNAVREG MIDWEST (N45)  
COMNAVREG SOUTHWEST (N45)  
COMNAVREG NORTHWEST (N45G)  
COMNAVREG HAWAII (N45)  
COMJTFREG MARIANAS (N40)  
COMNAVFOR JAPAN (N45)  
COMNAVFOR KOREA (N91)  
COMNAVREG EURAFSWA (N45)  
CCOMNAVREG EURAFSWA, Det Bahrain (EVSWA, N45)  
NAVFAC EURAFSWA (EV1)  
COMTHIRDFLT  
COMFOURTHFLT  
COMFIFTHFLT  
COMSIXTHFLT  
COMSEVENTHFLT  
NSWCCD-SSES

**TIERED RESPONSE REQUIREMENTS****RESPONSE TIMES:**

33 CFR 154 Required Response Times for Marine-Transportation- Related Facilities	Tier 1 Time Hrs.	Tier 2 Time Hrs.	Tier 3 Time Hrs.
<b>High Volume Port Areas (except for a TAPAA facility located in Prince William Sound, see 33 CFR 154.1135)</b>	<b>6</b>	<b>30</b>	<b>54</b>
<b>Great Lakes</b>	<b>12</b>	<b>36</b>	<b>60</b>
<b>All other river and canal, inland, and nearshore areas</b>	<b>12</b>	<b>36</b>	<b>60</b>

33 CFR 155 Required Response Times for Vessels	Tier 1 Time Hrs.	Tier 2 Time Hrs.	Tier 3 Time Hrs.
<b>High Volume Port Areas</b>	<b>12</b>	<b>N/A</b>	<b>N/A</b>
<b>Great Lakes</b>	<b>18</b>	<b>N/A</b>	<b>N/A</b>
<b>All other river and canal, inland, and nearshore areas</b>	<b>24</b>	<b>N/A</b>	<b>N/A</b>
<b>Open ocean (plus travel time from shore)</b>	<b>24</b>	<b>N/A</b>	<b>N/A</b>

40 CFR 112 Required Response Times for Non-Transportation-related Onshore and Offshore Facilities	Tier 1 Time Hrs.	Tier 2 Time Hrs.	Tier 3 Time Hrs.
<b>High Volume Port Areas</b>	<b>6</b>	<b>30</b>	<b>54</b>
<b>Great Lakes</b>	<b>12</b>	<b>36</b>	<b>60</b>
<b>All other river and canal, inland, and nearshore areas</b>	<b>12</b>	<b>36</b>	<b>60</b>

**RESPONSE CAPABILITY REQUIREMENTS CAPS BY OPERATING AREA:**

February 18, 1998 (40 CFR 112, 33 CFR 154 & 33 CFR 155)	Tier 1	Tier 2	Tier 3
<b>All except Rivers and Canals, Great Lakes</b>	<b>12.5K bbls/day</b>	<b>25K bbls/day</b>	<b>50K bbls/day</b>
<b>Great Lakes</b>	<b>6.25K bbls/day</b>	<b>12.3K bbls/day</b>	<b>25K bbls/day</b>
<b>Rivers and Canals</b>	<b>1.875K bbls/day</b>	<b>3.75K bbls/day</b>	<b>7.5K bbls/day</b>

*Note: 1) The caps show cumulative overall effective daily recovery capacity requirements, not incremental increases. Also, requirements for a given facility may be less.*

Enclosure (1)

## 10.4 Commercial Resources

### 10.4.1 Spill Response Contractors

A number of commercial response organizations exist within CNRH NOSC's AOR that can be contracted by using a United States Coast Guard (USCG) Basic Ordering Agreement (BOA). These commercial organizations, listed in Table 10.11, may be considered for response efforts as a supplement to the Navy facility equipment that already exists in the local area.

TABLE 10.11: SPILL RESPONSE CONTRACTORS				
Name	Day Phone	Other Phone	Response Time	Capability
PENCO	545-5195	524-2307 (fax)	< 12 hours	Can provide on-water containment and recovery, and on-land cleanup capabilities.
NRC <sup>1</sup>	631-224-9141	-	< 12 hours	Can provide on-water containment and recovery, on-land cleanup capabilities, and dispersant coverage (including dispersant aircraft).

NOTES  
<sup>1</sup>The CNRH NOSC Representative can also access the services of the NRC by going through U.S. Navy SUPSALV.

ADDRESSES:

- PENCO, 65 N. Nimitz Hwy, Pier 14, Honolulu, HI 96817
- NRC, 3500 Sunrise Highway, Suite 200, Building 200, Great River, NY 11739

### 10.4.2 Commercial Barge Services

Table 10.12 lists commercial barge services for the State of Hawaii and may have barges available for use as temporary storage of recovered oil.

TABLE 10.12: COMMERCIAL BARGE SERVICES		
Company Name	Address	Phone Number
American Marine Corporation	65 N. Nimitz Hwy, Pier 14 Honolulu, HI 96817	545-5190
Matson Navigation Company	1411 Sand Island Parkway Honolulu, HI 96819	462-8766
Kirby Offshore Marine, LLC	Pier 21, Honolulu, HI 96813	522-1000
Aloha Marine Lines	709 N. Nimitz Hwy, Pier 29, Honolulu, HI 96817	536-7033
Young Brothers	1331 N. Nimitz Hwy Honolulu, Hawaii 96817	543-9311
Sause Bros.	705 N Nimitz Hwy, Honolulu, HI 96817	521-5082
Healy Tibbits Builders	99-994 Iwaena St., Ste. A Aiea, HI 96701	487-3664

## 10.5 State Resources

The Hawaii Area Contingency Plan details the resources that are available around the State.

## 10.6 Federal Response Resources

Table 10.13 provides a matrix of Federal response resources that have expertise in OHS spill response.

<b>TABLE 10.13: FEDERAL SPECIAL TEAMS</b>				
<b>Expertise</b>		<b>Resources</b>	<b>Locations</b>	<b>Contact Information</b>
<b>NSFCC</b> National Strike Force Coordination Center	International case coordination Response equipment location Spill management; logistics; PREP exercises	Coordination of all NSF resources, including coordination of combined strike team responses; National Spill Response Resources Inventory; Logistical coordination and spill management staff. PIAT (element of NSFCC)	Elizabeth City, NC	Contact direct at: (252) 331-6000 or via NRC at: (800) 424-8802 ACTIVATION BY NOSC REP
<b>Navy SUPSALV</b> Supervisor of Salvage	Ocean oil spill abatement Shipboard damage control; Diving/ROV expertise; U/W search/recovery; U/W ship husbandry; Ship salvage plans and operations	Specialized pumping and skimming equipmt; Open ocean boom; Boom mooring equipment & fireboom; ROVs; Shipboard damage control equipment; Ship salvage equipment repair, rigging, command and control; Boats, decon vans; Salvage contracts.	Equipment locations are: JBPHH, HI Port Hueneme, CA Anchorage, AK Williamsburg, VA Worldwide salvage contracts	Contact direct: Day: (202) 781-1731 Press option #2 Night: (202) 781-3889 or via NRC at: (800) 424-8802 ACTIVATION BY NOSC REP
<b>NSF</b> USCG Strike Teams Atlantic Strike Team Gulf Strike Team Pacific Strike Team	Lightering; Pumping; Boom; Skimming; Air monitoring; Site safety; Site security In-Situ burning; Dispersant application; Operational & technical expertise; Damage assessment	Cargo lightering pumps; Dewatering/deballasting pumps; Command posts; Chemical response (Level "A"); Open water oil Containment & recovery systems (OWOCRS); Air monitoring equipment; Temporary storage devises; Communications equipment	Atlantic - Ft Dix, NJ Gulf - Mobile, AL Pacific – Navato, CA	Contact direct at: (609) 724-0008 (Atlantic) (251) 441-6601(Gulf) (415) 883-3311(Pacific) or via NRC at: (800) 424-8802 ACTIVATION BY NOSC REP
<b>NOAA SSC</b> Scientific Support Coordinator	Resources at risk; Chemistry; Liaison with scientific community; Dispersant and bioremediation; Trajectories	CAMEO; Air plume modeling equipment; Oil trajectory modeling equipment; Chemical sampling analysis; Biological and water sampling equipment	USCG District Offices: Seattle, WA RTC Yorktown, VA Governors Island, NY	Contact specific SSC: Day: 725-5903 ACTIVATION BY NOSC REP
<b>PIAT</b> Public Information Assist Team	Public affairs and media management assistance; Public affairs training	Press office equipment; Photodocumentation equipment	Elizabeth City, NC	(252) 331-6000 ACTIVATION BY NOSC REP
<b>Oceana Regional Response Team (ORRT)</b>	Provides technical assistance to OSC's during spill responses	Technical assistance	Hawaii and Pacific Island	541-2710 EPA 535-3307 USCG ACTIVATION BY NOSC REP



**TABLE 10.13: FEDERAL SPECIAL TEAMS**

<b>TABLE 10.13: FEDERAL SPECIAL TEAMS</b>				
<b>Expertise</b>		<b>Resources</b>	<b>Locations</b>	<b>Contact Information</b>
<b>EPA ERT</b> Environmental Response Team	Treatment technology Hydrology; engineering; geology; chemistry; Biology; How <i>clean</i> is <i>clean</i> issue? Health and safety	Sampling equipment to conduct investigations related to the release of oil or hazardous substances; Analytical laboratory available  Air monitoring; Underwater ROV	EPA Headquarters, Emergency Response Division Washington DC Edison, NJ Cincinnati, OH	Email: Powell.greg@epa.gov ACTIVATION BY NOSC REP
<b>EPA Region IX Environmental Emergencies</b>	Technical assistance	Technical assistance		(800) 300-2193 ACTIVATION BY NOSC REP
<b>CDC</b> Center for Disease Control	Health hazard info. and assessment of exposure and dosage to individuals; Medical monitoring associated with oil etiologic agents.	Environmental health laboratory services	Atlanta, GA	(404) 639-3311 ACTIVATION BY NOSC REP
<b>ATSDR</b> Agency for Toxic Substance and Disease Registry	Chemical spill response; scientific consultation; medical; toxicological and chemical safety and information; support in evaluating and abating human health hazards	Health hazard and treatment information Medical consultation for exposed individuals and areas Limited air modeling Toxicologic, chemistry and medical officer staff	Atlanta, GA	(800) 232-4636 ACTIVATION BY NOSC REP

THIS PAGE INTENTIONALLY LEFT BLANK

## 11.0 WASTE MANAGEMENT AND DISPOSAL PROCEDURES

This section provides information on the requirements and procedures to properly collect, store, manage, and dispose of waste resulting from a spill response at the RHFSF.

The types of waste expected from a spill response include:

- Recovered oil
- Oil and water emulsions
- Oil-contaminated wastes such as:
  - Spent sorbents
  - Oil-contaminated debris and materials such as disposable personal protection equipment, rags, plastic bags or sheets, etc.
  - Oiled vegetation, soil and gravel
- Waste decontamination solutions and effluents from equipment and personnel decontamination operations
- Non-contaminated wastes from response operations

In the case of a large spill, where an Incident Command (IC) or UC has been set up, the Planning Section should prepare an incident specific Waste Management and Disposal Plan. This plan provides specific procedures to be used by the Disposal Group to ensure that all oil contaminated wastes generated by the incident are properly managed, containerized, marked and disposed. A template for the Waste Management and Disposal Plan is provided in Appendix D of this plan. This plan is prepared by the Environmental Unit in collaboration with the Disposal Group and shall be reviewed by the Operations Section Chief and the Planning Section Chief. The plan shall be approved by the IC or UC and made part of the Incident Action Plan. The execution of the plan by the Disposal Group shall be monitored by the Environmental Unit for its effectiveness. The plan shall be updated and modified as necessary. Any changes to the plan shall be approved by the IC or UC. It is recommended that a copy of this section be provided with the plan to the Disposal Group as a reference document.

### 11.1 Responsibility

The IC shall ensure that waste management and disposal operations comply with regulatory requirements and prevent risk to health and safety of response personnel and the public. Management and disposal of oil and wastes generated during cleanup operations is the responsibility of the Disposal Group. During the spill cleanup, the Disposal Group shall:

- Collect spill residue, other contaminated material, and all non-reusable cleanup materials, including disposable clothing, sorbents, brushes, rags, brooms, and containers. Package material in Department of Transportation (DOT) approved containers. Mark and label containers in accordance with DOT and EPA requirements.
- Thoroughly ventilate affected areas, especially if it is within an enclosed area, such as the Red Hill tunnel. Comply with all safety, health and fire protection requirements.

If necessary and requested by the IC, the NOSC shall activate the appropriate contracts or agreements for the cleanup. In the event of cleanup by outside contractor or agency, the NOSC shall maintain on-scene command and support cleanup as needed.

After the spill cleanup, the IC shall ensure that all waste and contaminated items generated by the incident are properly identified, containerized, stored, manifested, and disposed, recycled or reclaimed.

## **11.2 Waste Collection, Management, and Disposal Process**

Wastes shall be collected in drums, tanks, dumpsters or other appropriate containers that are compatible with the contents to avoid leaks, corrosion or adverse chemical reactions. All containers that hold liquids shall be stored on spill pallets or within impervious berms to prevent any leaks from entering streams, storm drains or other waterways. Large containers shall be placed on plastic sheets. Dumpsters that hold oil-contaminated debris shall be lined with plastic to prevent leaks. Containers that hold flammable or combustible materials shall be stored per fire prevention regulations and National Fire Protection Association (NFPA) 30.

Waste disposal shall comply with all Federal and State regulations. Prior to disposal, waste profiles, laboratory analyses, waste manifests and other documents shall be reviewed and approved by the Environmental Unit. Where possible, disposal of non-hazardous waste at H-Power, such as oil-contaminated absorbents, is preferred. Non-hazardous wastes that are to be disposed at local permitted landfills must meet all requirements of the destination facility. The request for clearance number from the landfill facility shall be signed by the Disposal Group Supervisor or the Environmental Unit Leader on behalf of the Region. When ready for transport, non-hazardous waste manifests shall be signed by the Disposal Group Supervisor. As part of the incident demobilization, all areas used to store waste containers shall be inspected for signs of leaks or spills. Clean up any spills and dispose of the wastes per this disposal plan.

The final step in executing the disposal plan is to submit all documents to the Documentation Unit related to waste identification, management and disposal. This includes laboratory analyses necessary to characterize the waste, photographs, manifests, waste profiles, etc. This is necessary to confirm that all wastes were properly managed in accordance with applicable Federal and State regulations and with Navy instructions.

### **11.2.1 Fuel to be Reclaimed and Sold**

In a major fuel release in the tunnel, it is anticipated that this will generate large quantities of fuel that has been contaminated by dirt, debris, water, etc. It is possible that this fuel can be reclaimed and sold by the government. If so, then this is not considered waste, including JP-5. Storage of this fuel while awaiting sale will likely be within existing storage tanks as directed by NAVSUP FLCPH Fuel Director. Transfer of the fuel from these storage facilities to the buyer is not part of the disposal plan procedures.

### **11.2.2 Waste Characterization**

Each waste stream must be characterized to determine if it is a regulated hazardous waste (HW) per Hawaii Administrative Rule (HAR) 11-261. This can be done through user's knowledge of the materials or the process by which these materials became wastes. For example, SDSs can provide data on certain characteristics such as flash point or pH that can be used to make the HW determination.

Table 11.1 provides general guidance on waste material classification and the appropriate disposal strategy. This is a general guide only and it is essential that the classification be verified for each specific incident. If necessary, samples should be analyzed to determine whether the waste meets the criteria of a hazardous waste or whether other disposal or recycling options exist. Laboratory analysis may also be necessary for disposal in permitted industrial landfills.

<b>TABLE 11.1: MATERIAL CLASSIFICATION AND DISPOSAL STRATEGY</b>			
<b>Material</b>	<b>Classification</b>	<b>Disposal Strategy</b>	<b>Disposal Facility</b>
Recovered Oil	Reclaimable	Process through NAVSUP FLCPH Fuel Oil Reclamation Facility (FORFAC) as off-specification petroleum for reclamation.	NAVSUP FLCPH FORFAC or permitted used oil processor
	HW	Containerize, label and dispose as HW according to regulatory requirements.	Permitted Treatment, Storage, and Disposal Facility (TSDF)
Oil-Contaminated Wastes	Nonhazardous Waste	Dispose as ordinary solid waste.	Permitted solid waste landfill
	HW	Containerize, label as HW according to regulatory requirements.	Permitted TSDF
Contaminated Soil	Nonhazardous Waste	Consult with Hawaii Dept. of Health to determine disposal or treatment method.	To be determined
	HW	Containerize, label as HW according to regulatory requirements.	Permitted TSDF
Contaminated Equipment	Nonhazardous Waste	Clean according to section maintenance procedures.	N/A
	HW	Decontaminate.	N/A
Waste Chemicals to Include DECON Solutions	Nonhazardous Waste	Process through NAVFAC HI Industrial Waste Treatment Center (IWTC) or contractor	NAVFAC HI IWTC or contractor
	HW	Containerize, label as HW according to regulatory requirements.	Permitted TSDF
Dead Wildlife	Protected Species	Consult with Fish and Wildlife Service.	To be determined
	Other Species	Consult with Fish and Wildlife Service.	To be determined
Personal Protection Equipment	Nonhazardous Waste	Clean and reuse where possible; dispose of as ordinary solid waste if unable to reuse.	Permitted solid waste landfill
	HW	Containerize, label as HW according to regulatory requirements.	Permitted TSDF
Sorbents	Nonhazardous Waste	Dispose of as ordinary solid waste.	Permitted solid waste landfill
	HW	Containerize, label as HW according to regulatory requirements.	Permitted TSDF
Other Response Wastes	Nonhazardous Waste	Dispose of as ordinary solid waste.	Permitted solid waste landfill
	HW	Containerize, label as HW according to regulatory requirements.	Permitted TSDF
Nickel-cadmium Batteries, Mercury Containing Lamps	HW or Universal Waste	Containerize, label as HW or universal waste according to regulatory requirements.	Permitted TSDF or universal waste destination facility
Lead-acid Batteries	Lead-Acid Batteries Being Reclaimed	Turn in to lead-acid battery reclaimer	Permitted battery reclaimer
Recyclable Materials	Nonhazardous	Recycle at the Region Recycling Center Bldg. 159 (474-9207) or private sector recycler	Recycling Center Bldg. 159 or private sector recycler

In some cases, laboratory analysis may be necessary to determine treatability or disposal options, such as possible disposal in the sewer system, at a bioremediation land farm facility, at the City's H-Power facility where it would be burned for energy recovery or disposal at a permitted industrial landfill. Analysis may also be necessary to determine if the wastes are regulated by the EPA as a HW. Sampling methods shall follow EPA SW-846. Use proper sample preparation and storage protocols as required by the analytical laboratory, e.g., sample preservatives, proper containers, cooling, QC blanks, etc. The chain of custody document shall include the waste container identifier. The waste management log shall also use this same identifier and the sample number for tracking purposes.

### 11.2.3 Waste Accumulation Areas

Wastes shall be stored in areas as determined by the IC or the SMT. If possible, waste storage areas shall be at or near the point where the waste is initially generated. This reduces the distance that the waste is transported from the immediate response site. This also reduces the chances of spills or leaks while the wastes are moved. However, if the quantity of non-HW is large and the storage area interferes with the response or cleanup activities, it may be necessary to store the wastes farther from the incident site. For non-HW, a paved area at NAVSUP FLCPH adjacent to Building 550 to store containers, tanks, etc. could be identified in the plan as a possible non-HW storage area.

Whenever possible, waste accumulation areas should be located away from storm drains, ditches, swales or any drainage system that leads to streams, rivers or Pearl Harbor. Existing paved areas in the area should be considered for use as a waste accumulation area. Where liquids or sludges are stored, consider placing plastic sheets on the ground to prevent any spills from being absorbed into the dirt or gravel. This would contaminate the environment as well as significantly increase the cost of demobilization. Also, storage areas for liquids or sludges should be bermed. Spill kits should be placed in close proximity to these storage areas and personnel should be trained in the proper use of these kits.

### 11.3 Temporary Storage for Collected Oil and Response Waste

Table 11.2 is an overview of the Navy-owned temporary storage available to CNRH for collected oil and response waste.

TABLE 11.2: TEMPORARY STORAGE FOR COLLECTED OIL AND RESPONSE WASTE		
EQUIPMENT	CAPACITY	LOCATION / POC / TELEPHONE
<b>Bulk Storage Equipment for Recovered Oil</b>		
SWOB Barge # 12 and 48	2 @ 70,000 gals.	Waterfront Operations Officer 474-6262
YON Barge # 328, 335, 336	# 328 @ 500,000 gals. # 335 @ 300,000 gals. # 336 @ 300,000 gals.	Fuel Department 473-7833 or 690-0115 (24 hours)
YON Barge # 281	300,000 gals.	Waterfront Operations Officer 474-6262

TABLE 11.2: TEMPORARY STORAGE FOR COLLECTED OIL AND RESPONSE WASTE		
EQUIPMENT	CAPACITY	LOCATION / POC / TELEPHONE
<b>Bulk Storage Equipment for Recovered Oil</b>		
NAVSUP FLCPH Upper Tank Farm Bulk Storage Tanks	Approximately 6,300,000 gals. each	Fuel Department 473-7833 or 690-0115 (24 hours)
NAVSUP FLCPH FORFAC Bulk Storage Tanks B-1 and B-2	2 @ 378,000 gals. each	Fuel Department 473-7833 or 690-0115 (24 hours)
Oil Storage Bladders	2 @ 136,000 gals. 4 @ 500 gals. 2 @ 26,000 gals. 2 @ 21,000 gals. 1 @ 290,000 gals.	Navy SUPSALV Hawaii ESSM Base (As of 12/2015) (202) 781-1731, Option #2 (during work hours) (202) 781-3889 (Duty Officer, after hours)
<b>Storage Equipment for Contaminated Wastes, Hazardous Wastes, and Other Response Wastes and Debris</b>		
Drums	Multiple @ 55 gals.	NAVFAC HI Environmental Services 471-1171
Dumpsters	Multiple @ Varies	NAVFAC HI Environmental Services 471-1171

Other storage equipment or containers are available from commercial sources. This includes oil-water separators, fractionalization (frac) tanks, intermodal portable tanks (IMO), intermediate bulk containers (IBC), tri-wall boxes, etc. Submit requests to obtain containers or storage equipment to the Logistics Section.

### 11.4 Waste Container Management

Collection, storage, management and disposal procedures for contaminated wastes generated during the response must be followed closely. Properly handle, label, store, transport, and dispose of oil, oil contaminated debris and other wastes in accordance with Federal, State and local environmental, safety, fire prevention and transportation regulations. Refer to the incident site safety plan for specific safety and health hazard mitigation measures, including PPE requirements. Use heavy duty plastic trash bags and plastic sheets to prevent leaks of liquids from contaminating the ground.

All waste containers shall be labeled when required by applicable Federal and State regulations. Figure 11.1 shows samples of the various labels that shall be applied to containers with waste. Other labels may be used if approved by the Environmental Unit.

FIGURE 11.1: WASTE CONTAINER LABELS

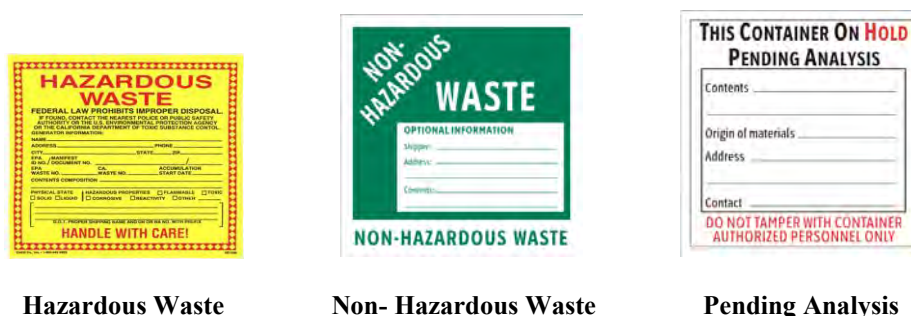

Hazardous Waste

Non- Hazardous Waste

Pending Analysis

In addition, if the waste requires a DOT hazardous material label based on its proper shipping name per 49 CFR 172.101, the HM label shall also be placed on the container next to the waste label while the container is in a storage area. Although not required by law when the container is not being transported, the DOT label alerts others on the hazardous contents of the container. If DOT regulated materials are stored in IMO's, tanker trucks, or other bulk container, placards should be placed per DOT regulations.

Containers must in good condition with no signs of holes, tears, leaks, excessive corrosion, bulging, etc. Containers must be compatible with the materials stored within them. They must be kept closed at all times except when adding or removing materials. All bungs, vents or drum lids must have gaskets that are in good condition to ensure that the container is liquid and vapor tight. Secure all container closures (bungs, vents, retaining bolts, etc.) with a wrench, i.e., not just “finger” tight. Containers to be transported on public roads must meet DOT requirements, including the appropriate performance oriented packaging packing group for that waste per 49 CFR 172.101.

Comply with fire prevention regulations when storing containers that hold flammable or combustible materials or wastes. Segregate containers holding incompatible materials. If required, fire extinguishers of the proper size and type must be placed near the containers with these flammable or combustible materials. If required, store flammable liquids in approved flammable liquid storage cabinets per NFPA 30.

All wastes shall be tracked in a waste log spreadsheet that is managed by the Disposal Group. Each container shall have a unique identifier consisting of the container code, date on which waste was first added into it followed by a sequential number. Use the container code as shown in Table 11.3. The date shall be in “yyyymmdd” format. For example, DM-20150218-1 is the identifier for the first metal drum that received waste on February 18, 2015.

<b>TABLE 11.3: WASTE CONTAINER CODES</b>			
<b>Container Type</b>	<b>Container Code</b>	<b>Container Type</b>	<b>Container Code</b>
Burlap, cloth, paper, or plastic bags	BA	Dump truck	DT
Fiber or plastic boxes, cartons, cases	CF	Wooden drums, barrels, kegs	DW
Metal boxes, cartons, cases (including roll-offs)	CM	Hopper or gondola cars	HG
Wooden boxes, cartons, cases	CW	Tank cars	TC
Cylinders	CY	Portable tanks	TP
Fiberboard or plastic drums, barrels, kegs	DF	Cargo tanks (tank trucks)	TT
Metal drums, barrels, kegs	DM	-	-

### **11.5 Disposal Conditions and Criteria**

Table 11.4 provides information on the conditions and criteria for the acceptance and disposal of waste material.



<b>TABLE 11.4: DISPOSAL STRATEGY, DISPOSAL CRITERIA, AND CONDITIONS</b>		
<b>Disposal Strategy</b>	<b>Disposal Facility and Location/ POC Information</b>	<b>Conditions and Criteria for Acceptance and Disposal</b>
Reclaim oil	NAVSUP FLCPH Fuel Department Director 473-7833 or 690-0115 (cell)	See NAVSUP FLCPH Instruction 4020.1, Fuel Reclamation at Fuel Oil Reclamation Facility
Nonhazardous waste disposal. Seal in drums or in lined dumpsters. Dispose of via contractor or NAVFAC HI	Contractor or NAVFAC HI/ Environmental 471-3858	Contact permitted landfill
Hazardous waste disposal	Permitted TSDF	Pertinent HW Management Plan
Incineration	H-Power, Covanta 682-2099	Only oil-contaminated debris, booms and sorbents approved for incineration by the city and county.
In-situ burning	Oceania RRT 541-2114	Hawaii ACP recommends in-situ burning for an ocean response but must seek RRT approval.
On-shore waste burning for response debris disposal	State On-Scene Coordinator, Elizabeth Galvez, 586-4249	Normally not recommended as a method for disposal.

## 11.6 General Waste Handling and Disposal Methods

The following briefly describes general disposal methods for various types of response-generated wastes and is provided for guidance only. The specific methods and procedures will be described in the incident specific Waste Management and Disposal Plan. If the collected materials are suspected to be mixed with hazardous wastes (examples: gasoline, halogenated solvents, acid, etc.), keep drummed wastes separate from non-contaminated wastes and notify the Environmental Unit immediately.

### 11.6.1 Solid Materials / Wastes (non-hazardous waste)

#### Oiled Natural Inorganic Materials (Oily Soil, Gravel)

1. Place into visqueen-lined dumpsters.
2. Decontaminate equipment used to excavate soil.
3. Sample soil and test if able to dispose at permitted landfill or at bioremediation facility.

#### Oiled Natural Organic Materials (Vegetation, Leaves, Branches, etc.)

1. Collect in translucent heavy-duty plastic bags, and then double bag to ensure that no leakage occurs.
2. Avoid collecting too much liquid (water or oil) in the bags. Drain excess liquids from bag or place absorbents in the bag before closing. Collect liquids and dispose per below. If only a small amount of liquid is present, add granular absorbents or pads to the bags. Place all bagged wastes into dumpsters or visqueen-lined roll-offs.
3. Transport to the on-site storage area or to central storage area adjacent to Bldg. 550.

Oiled Man-Made Materials (Oily Booms and Absorbent Pads, Oil-Contaminated Debris)

1. Collect in translucent heavy-duty plastic bags, and then double bag to ensure that no leakage occurs.
2. Avoid collecting too much liquid (water or oil) in the bags. Drain excess liquids from bag or place absorbents in the bag before closing. Collect liquids and dispose as oil or oily liquid wastes per below.
3. Place all bagged wastes into dumpsters or visqueen-lined roll-offs at the designated storage area.
4. Transport filled dumpsters to permitted landfill for disposal. If allowed by Covanta, H-Power can accept for incineration.

Oil Saturated Sorbents and Debris

1. The primary method of storage should be in roll off dumpsters. These dumpsters should be lined and covered as is the standard industry practice.
2. If sufficient dumpsters cannot be obtained, then an alternative method is to prepare an area by lining it with two layers of 6 mil plastic. Raise the edge of the plastic to serve as an impermeable berm. If there is a significant amount of oil that may drip from the material, then the plastic should be covered with a sorbent rug.
3. The area must be secured and access must be restricted.
4. Ingress and egress areas for heavy equipment must be maintained in a fashion which does not compromise the integrity of the liner.
5. Consideration must be given to covering the material to prevent excessive rain water from accumulation in the bermed area. This may also be required if the debris may be blown away by strong winds.

Solid Waste from Decontamination (Decon) Operations:

1. Collect dirt, debris, soiled PPE to be disposed, plastic sheeting, etc. in 55-gallon drums at each decon station. Other containers, such as IBCs or tri-walls with plastic sheet liners, may be used if specified in the Waste Management and Disposal Plan.
2. Label as “pending analysis”.
3. When all decon operations completed, collect samples, analyze and determine whether it is hazardous waste or if it can be disposed at a local industrial landfill.
4. Dispose based on laboratory analysis and per Environmental Unit.

Waste from Wildlife Rehab Operations:

1. Wastes from rehab operations will be collected in plastic bags. Filled bags will be placed in visqueen-lined roll-off bins and will be managed the same as solid oily debris.
2. Uncontaminated waste, such as paper towels, can be disposed as ordinary trash.

Oiled Animal Carcasses:

The disposal of dead oiled wildlife is the responsibility of the Wildlife Branch of the Operations Section. Before removing oiled wildlife carcasses, get specific guidance from the Wildlife Branch. The general handling methods are:

1. Collect in plastic bags.
2. Label with date and time animal found, location found, and person finding animal (name and phone number).
3. Put on ice (chill) but do not freeze.
4. Transport to location designated by Wildlife Branch.

### **11.6.2 Liquid Materials / Waste (non-hazardous waste)**

#### Oil and Oily Waste:

1. Collect material with pumps or vacuum trucks.
2. Transport to location of temporary storage and empty into collection equipment or tanks.
3. Collect sample, analyze and determine whether or not it can be reclaimed and if it is a HW.
4. If acceptable, reclaim recovered oil through the NAVSUP FLCPH FORFAC. If the oil is unacceptable by the NAVSUP FLCPH FORFAC, dispose per the incident Waste Management and Disposal Plan.

#### Rinse Water Waste from Decon Operations:

1. Collect rinse water in 55-gallon drums or tote at each decon station.
2. Label container as “pending analysis”.
3. When all decon operations completed, collect samples, analyze and determine whether it is HW, if it can be processed as industrial waste water via a contractor or discharged into the sewer system.
4. Dispose based on laboratory analysis and as directed by the Environmental Unit.

#### Waste from Wildlife Rehab Operations:

1. All oily water recovered from rehab operations will be stored in a portable tank for further analysis / waste characterization.
2. Dispose based on analysis.

### **11.6.3 Oil in Pearl Harbor or Contributing Streams:**

#### Recovered Product from Skimmer Boats

The On-Water Recovery Group will recover petroleum product from within the harbor using skimmer boats. Minimize the use of absorbent sweeps or pads if possible. When the skimmer tanks are full, the boats shall return to Ford Island or another site designated by the Recovery Group Supervisor and remove the oil with vacuum trucks. The vacuum trucks shall transfer the product to a SWOB or directly into the FORFAC after first tested and approved by the NAVSUP FLCPH Fuel Lab at Building 1685 for acceptance. The recovered product will be transferred from the SWOB via vacuum trucks and taken to the FORFAC for reclamation.

#### Recovered Product for Shore Side Skimmers

If the oil is near a pier or wharf and accessible to vacuum trucks, the Shore Side Recovery Group will use skimmers and vacuum trucks from dockside and remove the oil. The vacuum trucks will then empty the oil into a SWOB or directly into the FORFAC. Minimize the use of absorbent sweeps or pads if possible.

### **11.7 Non-Hazardous Waste Disposal Methods**

There are several options for disposal of non-hazardous wastes. Each will require review of all documentation by the Environmental Unit. Once approved, the Disposal Group Supervisor can sign the shipping papers. In some cases, disposal at a permitted solid waste landfill will require submitting a request for clearance by the landfill operator. The Environmental Unit will prepare the request and sign the application on behalf of the landowner.

Ordinary trash from the incident command post, rest areas, etc., can be disposed in dumpsters without complying with the requirements stated above. However, ensure that no regulated wastes are disposed as ordinary trash.

### **11.8 Recyclable Materials**

Wherever possible, items should be recycled instead of disposed. These include corrugated cardboard boxes, uncontaminated steel or non-ferrous metals, clean plastic (type 1 or 2), aluminum and glass beverage cans, etc. The Environmental Unit will coordinate with the Region Recycling Center for specific recyclable items that they will accept. Private sector recyclers can also be used.

### **11.9 Annual Solid Waste Disposal Documentation**

At the end of each fiscal year, the amount of wastes disposed, reclaimed or recycled from response and cleanup related to the spill incident for that FY shall be recorded and submitted to NAVFAC HI Code EV13. The Environmental Unit will be responsible for completing this form. This is to comply with the CNO annual solid waste reporting requirements.

## 12.0 EVACUATIONS

The following evacuation procedures are based on information provided by the FFD. Evacuation routes maps are posted throughout the Red Hill facility.

### 12.1 Notification of Serious or Facility-Wide Emergency Situation

A serious or facility-wide emergency situation such as a major fuel leak, fire, smoke, or explosion, will require that all or the majority of the RHFSF be notified and evacuated. The preferred means of notification is the activation of the fire alarm pull station, which will activate flashing lights, repeated horn blasts, and recorded verbal announcements throughout the facility.

Fire alarm pull stations, thermal heat detectors, smoke detectors, and ultra violet infrared detectors are located at strategic locations throughout the facility. If one of these devices is tripped, audible and visual alarms will activate throughout the facility and the FFD is notified of the alarm.

Emergency phones (blue boxes) are located throughout the facility and a “giant voice” system enables messages to be broadcast through speakers facility-wide. See Appendix F for the “frame foot mark” location of every emergency phone in the RHFSF.

### 12.2 Emergency Evacuation Zones, Escape Routes, and Assembly Areas

The RHFSF is divided up into 6 emergency evacuation zones; each zone has a primary and alternate escape route and a designated assembly area as shown in Figure 12.1. Evacuation route maps are located throughout the facility and will glow in the dark in the case of a power failure. Note that for emergency evacuation zones 5L and 6L, in the LAT, that you must take one of the elevators, located on either side of Tanks 17 and 18, up to the UAT to reach your primary escape route exit. In the case of a power failure, there are escape ladders adjacent to each elevator that provide access to the UAT.

In the event of an emergency requiring evacuation of the RHFSF, all employees, visitors, and contractors are to leave the facility by the designated primary escape route for their emergency evacuation zone. Once out of the RHFSF personnel shall gather in their designated assembly areas and remain there until receiving further instructions. Should the primary escape route be in a hazardous area, employees will then use the alternate escape route and assemble outside the nearest adit that is deemed to be safe. Employees will report to their supervisor. Supervisors will notify the Control Room Operator at 471-8081 as to the status of personnel assigned to them. The Control Room Operator tracks all personnel (employees, contractors, and visitors) that scan in and out of the RHFSF using the “Identipass Plus” system. The operator will check his system count against the “Head Count” provided by supervisors to account for all personnel.

Depending on the emergency, the COMPACFLT Building (Building 250) may need to be evacuated due to its proximity to the Adit 2 Spur Tunnel. The Regional Dispatch Center will notify the COMPACFLT Command Duty Officer at 471-3201 of any serious or facility-wide emergency within the RHFSF.

### 12.3 General Emergency Evacuation Procedures

ALL PERSONNEL SHALL BE FAMILIAR WITH THESE PROCEDURES BEFORE THE NEED TO EVACUATE THE RHFSF EVER ARISES.

- All personnel must be familiar with the emergency evacuation zones at the RHFSF and the associated primary and alternate escape routes (see Figure 12.1).
- When an evacuation is announced, STOP WORK. Keep calm and avoid panic, and move to the designated assembly area for your zone.
- When evacuating the RHFSF, WALK to your designated exit. DO NOT RUN, nor linger.
- Leave the RHFSF and report to your designated assembly area (if safe), or to a safe area away from the adit. REPORT to your supervisor once outside the adit or building and follow his/her instructions. Stay in your assigned safe area until instructed otherwise.
- Emergency escape Self-Contained Self-Rescue (SCSR) breathing apparatuses are available for use by trained NAVSUP FLCPH employees and accompanied guest, to escape or shelter in place in hazardous atmospheric conditions. Emergency escape SCSR breathing apparatuses are located in storage lockers located near Tanks 1 and 19 in the upper and lower tunnels, and also outside the Control Room at Adit 1.
- Supervisor must conduct a “Head Count” and report to the Control Room Operator at 471-8081 when his/her employees have cleared the facility, and if anyone is missing. Contractors will be responsible for accounting for all of their employees and reporting to the Control Room Operator.
- Determine the need for evacuation of residential and commercial areas near the incident site. Evacuation distances and directions will be defined based on consultation of the appropriate technical references (e.g., DOT Emergency Response Guidebook), expert advice (e.g., Fire Department Chief in case of actual potential fire or explosion), actual conditions (e.g., confined spaces, movement of toxic fumes), and response plans.
- If nearby residential and commercial areas or base residents need to be evacuated, initiate and coordinate the evacuation procedure in accordance with the CNRH Emergency Management (EM) Plan and contact the CNRH Navy On-Scene Coordinator (NOSC) for assistance (473-4689 work, 864-2463 cellular, ROC 473-3215).

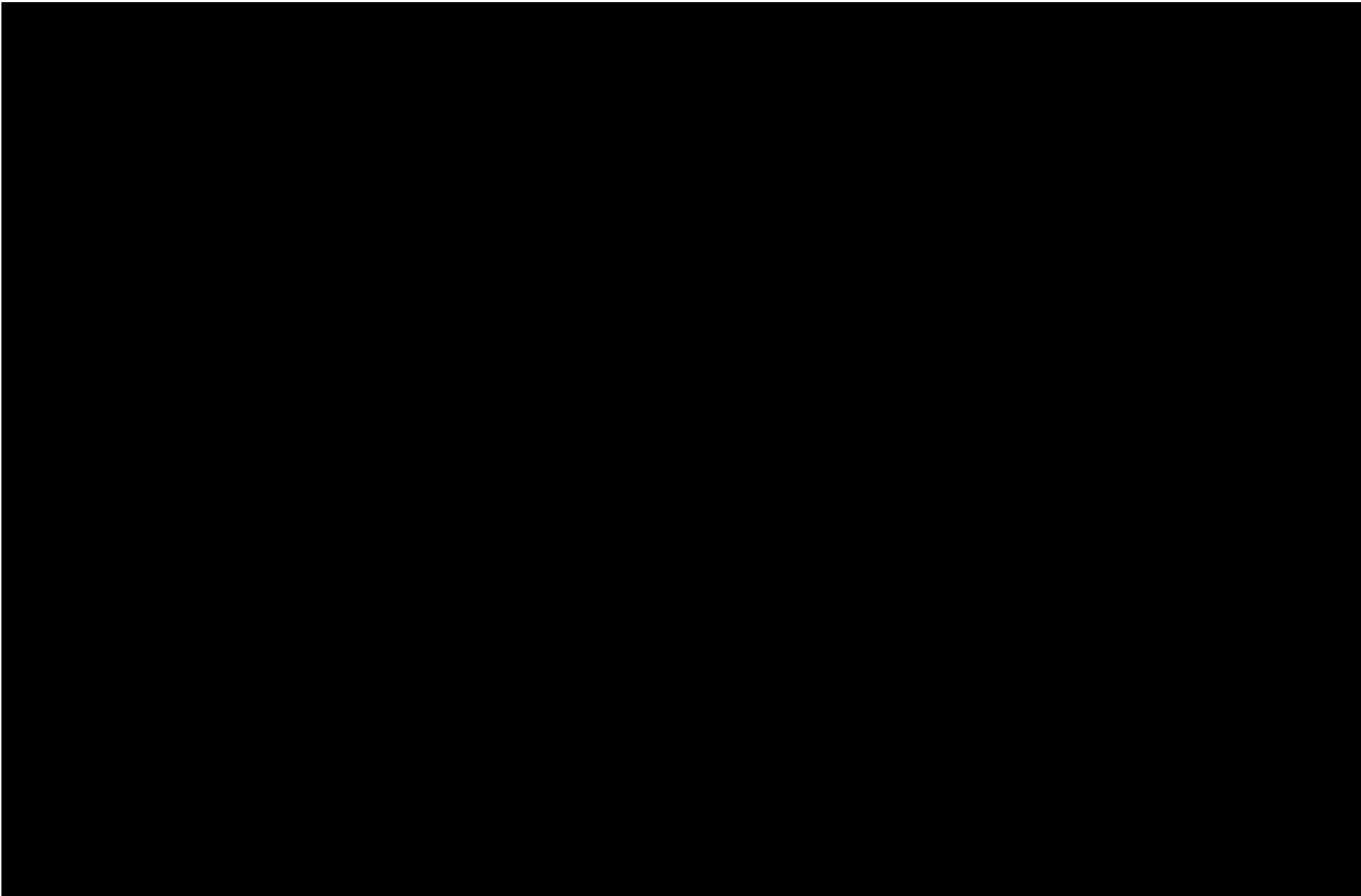

THIS PAGE INTENTIONALLY LEFT BLANK



### 13.0 REFERENCES

The following references were used in the development of this plan:

Bechtel Corporation, 1949, *Engineering Survey of U.S. Navy Petroleum Facilities at Pearl Harbor*, May 1949, 181 pp.

Center Relay, 2009, *The Underground*, Center Relay Special Edition, March 2009, 12 pp.

Commander Navy Region Hawaii, 2018, *Commander Navy Region Hawaii Integrated Contingency Plan*, Prepared for NAVFAC HI, Prepared by PCCI, Inc., August 2018, ~500 pp.

Commander Navy Region Hawaii, 2010, *Final Summary Report Red Hill Fuel Storage Facility*, Prepared for Commander Navy Region Hawaii, Prepared by TEC Inc., August 2010, 92 pp.

Commander Navy Region Hawaii, 2008, *Red Hill Tunnel Fuel Storage Facility Emergency Response Plan*, Prepared for Commander Navy Region Hawaii, Prepared by the Federal Fire Department and NAVSUP FLCPH, March 2008, 51 pp.

Defense Fuel Support Point Pearl Harbor, 2018, *Operation and Maintenance Manual Defense Fuel Support Point Pearl Harbor Bulk Terminal, Pearl Harbor, Hawaii*, Prepared for U.S. Army Corps of Engineers, Prepared by Trinity/Bhate JV, LLC, August 2018, 882 pp.

NAVFAC, 2007, *Red Hill Bulk Fuel Storage Facility Technical Report*, Prepared for NAVFAC, Prepared by TEC Inc., August 2007, 174 pp.

NAVFAC, 2008, *Red Hill Bulk Fuel Storage Facility Final Groundwater Protection Plan*, Prepared for NAVFAC, Prepared by TEC Inc., January 2008, 359 pp.

NAVFAC, 2019, *Conceptual Site Model, Investigation and Remediation of Releases and Groundwater Protection and Evaluation*, Prepared for Defense Logistics Agency Energy, Prepared by AECOM Technical Services, Inc., June 2019

Rogers, J. D., (Date Unknown), *Red Hill Storage Tanks* (pdf), Retrieved from: <http://web.mst.edu/~rogers/umrcourses/ge342/Red%20Hill%20Storage%20Tanks-revised.pdf>

Woodbury D., 1946, *Builders for Battle: How the Pacific Naval Air Bases Were Constructed*, Dutton and Company Inc., 1946, 225 pp.

THIS PAGE INTENTIONALLY LEFT BLANK.

**APPENDIX A - NOTIFICATIONS**

THIS PAGE INTENTIONALLY LEFT BLANK

<b>TABLE A.1: SPILLER NOTIFICATION CHECK-OFF LIST</b>		
<b>Agency Or Department</b>	<b>Phone No.</b>	<b>Notified</b>
Qualified Individual / NOSC Representative	473-4689 (Office) 864-2463 (24-hour)	Person Notified: _____ Date / Time Notified: _____
National Response Center (NRC)	800-424-8802 (24-hour) 202-267-2675 (Direct #)	Person Notified _____ Date / Time Notified: _____ Report No (as applicable): _____
Hawaii State Emergency Response Commission (HSERC)  Provide follow-up written notification within 30 days of initial notification	586-4249 (Days) 247-2191 (After Hours)	Person Notified: _____ Date Notified: _____ Time Notified: _____ Report No. (as applicable): _____
Honolulu Local Emergency Planning Committee (LEPC)  Provide follow-up written notification within 30 days of initial notification.	723-8960 (24-hour) 911 (Emergencies)	Person Notified: _____ Date / Time Notified: _____ Report No. (as applicable): _____
Honolulu Board of Water Supply  If Navy well at Red Hill Facility is threatened.	748-5000, Ext. 1	Person Notified: _____ Date / Time Notified: _____
Provide follow-up navy message within 24-hours of discovery	See OPNAVINST 5090.1(Series) Message Reports Format	NA

<b>TABLE A.2: INTERNAL NOTIFICATIONS</b>		
<b>Contacts</b>	<b>Day Telephone</b>	<b>24-Hour Telephone</b>
NOSC (Admiral - CNRH)	473-2200	473-3215/3216 Regional Operations Center (ROC)
NOSC Representative	473-4689	864-2463 (24-hour)
Alternate NOSC Representative	471-1171 x 210	864-2463 (24-hour)
COMPACFLT Area Environmental Coordinator (AEC)	471-0632	471-3201 (CDO)
Regional Dispatch (Fire Dept., Security, Medical)	911 471-7114	911 471-7114
JBPHH Quarterdeck	473-1222	473-1222

<b>TABLE A.2: INTERNAL NOTIFICATIONS</b>		
<b>Contacts</b>	<b>Day Telephone</b>	<b>24-Hour Telephone</b>
JBPHH Emergency Operations Center (EOC)	448-2752/2753	448-2752/2753
JBPHH Security	911 or 474-2222	911 or 474-2222
CNRH ROC	473-3215/3216	473-3215/3216
Safety	473-1169	473-1169
Liaison	473-4141	368-3150
Public Information	473-2875	554-4813
Legal	473-4731	864-2461
CDOs		
a. COMPACFLT	a. 471-5452	a. 471-5452
b. NAVSUP FLCPH	b. 216-1339	b. 216-1339
c. NAVFAC HI	c. 778-4839	c. 778-4839
d. NCTAMS PAC	d. 653-5385	d. 653-5385
e. PHNSY & IMF	e. 449-8000 x 1339	e. 473-8000 x 1339
NAVFAC HI Emergency Service Desk	449-3100	449-3100
NAVFAC HI Environmental	471-3858	471-3858
NAVSUP FLCPH Fuel Department Control Room, Adit 1 Control Room, Building 1757 Fuel Service Center (Hickam Bulk Tanks)	473-7801 471-8081/473-1075 473-7804/473-7837 449-2509	216-1339 (CDO) 216-1339 (CDO)
Port Operations Control Tower	474-6262 or Channel 69	474-6262 or Channel 69
Facility Response Team (FRT)	472-9942	472-9942
COMPACFLT Salvage Officer	474-5490/6372	471-5452 (Duty Officer)
Emergency Ship Salvage Material (ESSM) Base Hawaii	423-7055 423-6535 (fax)	423-7055 423-6535 (fax)
Mobile Diving Salvage Unit 1 (MDSU 1)	471-9292	471-9292
Navy SUPSALV	202-781-1731 (Option #2) 202-781-3889 (After Hours)	202-781-1731 (Option #2) 202-781-3889 (After Hours)
COMNAVSURFGRU MIDPAC	473-3560	473-3560
Rainbow Bay Marina	473-0279	473-0279
USS Arizona Memorial	422-3399	422-3399
USS Bowfin Submarine Museum & Park	423-1341	423-1341
USS Missouri Memorial	455-1600	455-1600

<b>TABLE A.3: EXTERNAL NOTIFICATIONS</b>		
<b>Agencies To Notify</b>	<b>Action</b>	<b>Telephone Number</b>
US Coast Guard Sector Honolulu	In the event the NOSC cannot be contacted, notify the USCG Sector Honolulu.	843-3811
US Coast Guard District 14 Command Center	Additional resources.	800-331-6176

<b>TABLE A.3: EXTERNAL NOTIFICATIONS</b>		
<b>Agencies To Notify</b>	<b>Action</b>	<b>Telephone Number</b>
Hawaiian Islands National Wildlife Refuge	Contact if wildlife, wetlands, or refuges are threatened or impacted.	792-9548
U.S. Fish and Wildlife Service, Pacific Island Office	Notify if Federal natural resources are threatened or impacted.	792-9400
National Park Service - USS Arizona	Notify if park lands or memorials are threatened or impacted. Superintendent, USS Arizona Memorial.	422-3399
NOAA – Scientific Support Coordinator (SSC)	For advice on scientific issues, communicate with scientific community, coordinate state and Federal agency requests for specific study assistance and assist On-Scene Coordinator with spill movements and trajectories.	206-849-9926 (office)
NOAA – National Marine Fisheries Service Pacific Island Regional Office	Notify if protected marine species are threatened or impacted. Notify as a natural resources trustee and to assist in spill response if turtles are injured.	725-5000 725-5215 (fax)
Agency for Toxic Substances and Disease Registry	Health information related to the toxicity, chemistry, and decontamination of hazardous materials.	800-232-4636 (24-hr)
Hawaii Poison Control Center	Provides toxicological information and medical treatment advice for responders.	800-222-1222 (24-hr)
Honolulu Department of Emergency Management	Department of Emergency Management	723-8960 524-3439 (fax)
Oceania Regional Response Team (RRT)	Notify if public health emergency exists, or may occur.	972-3081 (EPA) 541-2103 (USCG)
NOAA Weather Service	Weather and water conditions and forecasts.	973-5286 (24-hr)
FEMA – Pacific Area Office	If incident presents or may present a MAJOR disaster.	851-7900

<b>TABLE A.4: SPILL RESPONSE CONTRACTORS</b>				
<b>Name</b>	<b>Day Phone</b>	<b>Other Phone</b>	<b>Response Time</b>	<b>Capability</b>
PENCO	545-5195	524-2307 (fax)	< 12 hours	Can provide on-water containment and recovery, and on-land cleanup capabilities.
NRC <sup>1</sup>	631-224-9141	-	< 12 hours	Can provide on-water containment and recovery, on-land cleanup capabilities, and dispersant coverage (including dispersant aircraft).

Notes:

<sup>1</sup>The CNRH NOSC Representative can also access the services of the NRC by going through U.S. Navy SUPSALV.

Addresses:

- PENCO, 65 N. Nimitz Hwy, Pier 14, Honolulu, HI 96817
- NRC, 3500 Sunrise Highway, Suite 200, Building 200, Great River, NY 11739

THIS PAGE INTENTIONALLY LEFT BLANK



**APPENDIX B - FINANCIAL RESPONSIBILITY**

THIS PAGE INTENTIONALLY LEFT BLANK

## APPENDIX B - FINANCIAL RESPONSIBILITY

### B.1 NAVY RESPONSIBILITY

#### B.1.1 Pollution Response Funding

Naval activities are mission-funded to perform "housekeeping" cleanup associated with minor pollution incidents. However, the spiller is responsible for all costs incurred for the response and cleanup of pollution incidents caused by a Navy ship or activity. The major claimant or Type Commander (TYCOM) of the spiller is ultimately responsible for funding of the response/cleanup effort. Because major pollution incidents occur so infrequently, there is no funding earmarked to support oil and hazardous substance (OHS) cleanup activities in the Department of Defense (DOD) Future Years Defense Plan (FYDP). Consequently, no naval activity has a pre-established source of emergency funding for pollution cleanup.

#### B.1.2 NOSC Responsibility

It is CNRH's or the local responding activity's responsibility to initiate immediate effective response activities for Navy OHS pollution incident that occurs within its area of responsibility (AOR). The NOSC or responding activity should seek a formal line of accounting data, funding citation, or reimbursement from the spiller's chain of command as soon as possible. Lack of an immediate funding transfer from the spiller to the responder must not delay unified Navy action. In those situations where the NOSC must initiate response actions without advance funds from the spiller, the cost verification procedures described in Section B.1.8 are critical.

#### B.1.3 Initial Emergency Funding

When a medium or major pollution incident occurs, the responsible party (spiller) must quickly identify and allocate funds for cleanup expenses. When appropriate, initial funding can be provided by a responding local Navy shore activity for later reimbursement. If funds greater than those initially available from the spiller or local shore activity are required, the spiller's TYCOM or major claimant should be requested to provide additional funds. An estimate of funds required and a schedule of when those funds must be available should be developed by the CNRH SMT in particular the Operations Group, as soon as possible during the first phases of the response.

#### B.1.4 Funding Limitations

The amount of funding immediately available should not limit the extent of the initial response effort. When necessary, contracts for outside sources may be written with limited periods of performance and cost ceilings to the extent of available funds. Follow-on negotiations and contract modifications can be implemented as additional funds are received. The availability of follow-on funding availability will be directly related to the severity of the pollution incident. When appropriate, CNRH should contact the spiller's next in command and request prompt funding of the cleanup operation.

### **B.1.5 Estimating Cleanup Costs**

During the initial pollution assessment, the CNRH SMT should evaluate the magnitude of the incident and estimate all cleanup costs. Exact cost estimating is not necessary. However, failure to properly estimate costs could delay final funding of the cleanup effort as repetitive funding transactions are briefed and executed through the spiller's chain of command. Assistance in estimating cleanup costs for large or complex operations should be obtained from Navy SUPSALV or USCG Sector Honolulu.

### **B.1.6 Navy Reimbursement Procedures**

At the conclusion of the response, a full accounting of all funds received and expenses incurred during the response must be made. After the full accounting, requests to the spiller for reimbursement of any costs incurred by CNRH or other commands for the pollution response can then be made. The following are examples of pollution response expenditures that are reimbursable from the spiller's major claimant:

- Navy Working Capital Funded (NWCF) activity cost including full labor costs and overhead.
- Travel and per diem costs of personnel who were requested to directly support the response effort.
- Local or state government costs in direct support of the response effort.
- Requested and approved overtime for Navy civilian personnel.
- Fuel expended by Navy or government vessels, vehicles, and aircraft which were requested by the NOSC to support the response.
- Supplies, materials, or minor equipment procured specifically for the response.
- Rental or lease of equipment obtained specifically for the response.
- Transportation of equipment not otherwise funded.
- Cost of civilian cleanup or disposal companies who were directly contracted by the NOSC.
- Contracted scientific/technical support.
- Repair, maintenance, and refurbishment of equipment used in the response.
- Return transport of equipment not otherwise funded.
- Final disposal of recovered oil, hazardous substance (HS), and debris.

### **B.1.7 Funding Documentation**

All requests for equipment or services must be documented. A verbal request must be confirmed by an appropriate funding document or other acceptable record containing the full line of accounting data with cost ceilings from the spiller, major claimant, or TYCOM.

### **B.1.8 Cost Verification**

When services or equipment are contracted, the NOSC is responsible for verifying that the contractor performs as required by contract and that costs submitted for payment are factual. The assignment of additional on-site personnel may be required for proper cost verification.

Commercial contracts issued for pollution cleanup contain provisions for daily cost summaries and specify the method for verification of performance.

## **B.2 DLA ENERGY RESPONSIBILITY**

### **B.2.1 Reimbursement for Spill Related Costs**

To be funded for spills, prompt notification to DLA Energy must be made. Spills should be handled at the facility level as an emergency situation. This means that facilities should not wait for funding from DLA Energy before committing funds to begin responding to a release. Prompt cleanup will limit total cleanup costs by minimizing the spread of contamination. DLA Energy will “reimburse” for funds used in spill response and/or cleanup costs that involve DLA Energy managed petroleum as long as proper documentation is provided and the spill did not result from gross operator negligence (see Section B.2.6). DLA Energy will not reimburse the facilities for military and civilian personnel salaries except for those overtime hours of federal civilian employees directly involved in the spill response and/or cleanup. If it is determined that a spill has occurred and that not all of the product identified is from the current spill, DLA Energy will only fund those costs which can be associated with the current spill.

### **B.2.2 Documentation Requirements**

Documentation needed for spill response and cleanup funds include the following:

- Situation report or incident report
- Breakdown of costs associated with initial response and cleanup efforts
- Itemized costs for proposed cleanup actions
- Projected schedule for long-term remediation costs

DLA Energy will review costs submitted for funding and will fund applicable spill related costs.

### **B.2.3 Situation Report**

DLA Energy requires that the spiller include the following information in a situation report (to the extent practicable) to NAVSUP and DLA Energy as soon as possible. The initial report should not be delayed in an attempt to gather additional information. This following list is not all inclusive; any additional information relevant to the spill event should be identified and forwarded to NAVSUP and DLA Energy as soon as it becomes available:

- Date of spill event
- Type of fuel spilled/released
- Amount of spill/release (in gallons)
- Cause of spill/release
- If spill/release has been contained
- Current status of initial response
- Amount of product recovered to date
- Navigable waters impacted by product, if any

The following information should be included in a follow-up report to DLA Energy and NAVSUP:

- If spill/release caused by equipment failure, then;
  - Has equipment been repaired?
  - Has equipment been tested (include test dates)?
    - What type of testing was done?
    - What are the results of testing?
  - Has a project been prepared to repair/replace the equipment?
  - What is current status of repair project?
- Will a site assessment be required?
  - When will site assessment begin?
- Will further remediation be required? If remediation will be required then:
  - What type of remediation is being considered?
  - Have federal, state or local authorities been informed of the planned remediation?
  - Has the appropriate regulatory agency given approval of the remediation plan?
- Has groundwater been impacted?
  - Is affected groundwater a source of drinking water?

Provide copies of any maps which identify the spill site and the location of the impacted area. Maps should be of adequate scale to indicate the impacted area and should identify all structures in the immediate area of the spill site

#### **B.2.4 Spill Management**

DLA Energy will not assume management of any portion of the spill response/cleanup. Management of the response/cleanup effort will remain the responsibility of the CNRH SMT or NAVSUP FLCPH. If requested by the spiller, DLA Energy will provide guidance/assistance with the cleanup effort, when possible. DLA Energy assumes no operational responsibility at any facility unless so requested by the activity.

#### **B.2.5 DLA Funding Request**

Facilities should request environmental compliance funding (includes POL spill cleanup) from DLA Energy via the online DLA Enterprise External Business Portal (EEBP) found at: <https://business.dla.mi>. Once a request is entered into EEBP, the request is automatically routed to Major Command (MAJCOM) for approval and sent to the respective service control point (SCP). Supporting documentation should be included with the request, such as statements of work, contract award documents, invoices, and other documents.

The SCPs verify the EEBP request is eligible for funding and ensures that valid and complete environmental funding requests are channeled to DLA Energy for processing. For a funding request to be considered eligible for DLA Energy funds, it must directly support the DLA bulk petroleum management mission and be related to capitalized product. Funds for approved requests will be provided through a military interdepartmental purchase request (MIPR).

#### **B.2.6 Non-Fundable Costs**

Once DLA Energy-owned product has been delivered to the end user vehicle (e.g.: refueling truck, aircraft, ship etc.) it is no longer the responsibility of DLA Energy. For example, flight line spills, over the road truck spills, vehicle fuel dumping, ship to ship fuel transfer, spills

resulting from gross operator negligence, etc., would not be eligible for DLA Energy cleanup funding. Costs associated with these types of spills will be funded by the individual military service

**B.2.7 Contact Information**

DLA Energy - Customer Interaction Center

Telephone: 877-352-2255

DSN: 877-352-2255

DLA Energy - Operations Center (24/7)

Telephone: 571-767-8420

THIS PAGE INTENTIONALLY LEFT BLANK



**APPENDIX C - SPILL INFORMATION LOG**

THIS PAGE INTENTIONALLY LEFT BLANK

<b>TABLE C.1: SPILL INFORMATION LOG</b>	
<b>SECTION 1 – INITIAL RELEASE INFORMATION (Initial notifications must not be delayed pending collection of data)</b>	
<b>Spiller:</b>	<b>Discoverer:</b>
Phone # (duty & non-duty):	Phone # (duty & non-duty):
<b>Incident Description:</b>	
Date of Spill:	Time of Spill:
Spill Location:	
Spilled Product:	
Total Amount Spilled (specify units-gals, lbs., etc.):	
Spill Description (size/color/fumes/etc.):	
<b>SECTION 2 – RELEASE INFORMATION DETAILS</b>	
<b>Source and Cause of Incident:</b>	
Spill Source/Cause:	
Operations(s) Under Way When Spill Occurred:	
<b>Response Actions:</b>	
Actions Taken to Stop Release:	
Containment Method Planned/Used:	
Clean-Up Method Planned/Used:	
Parties Performing Spill Containment/Clean-Up:	
Samples Taken: Yes ____ No ____	
Volume of Product Recovered (in gallons):	

<b>TABLE C.1: SPILL INFORMATION LOG</b>						
<b>Impact/Health Threats:</b>						
Number of Injuries:	Number of Deaths:					
Describe Any Evacuations Including Number Evacuated:						
Describe Any Property Damaged:						
Description of Environmental and Health Threats Including Areas Threatened:						
<b>Notifications:</b> NOSC: Yes ___ No ___ Date: _____ Time: _____  NRC: Yes ___ No ___ Date: _____ Time: _____ Report No. _____  SERC: Yes ___ No ___ Date: _____ Time: _____ Report No. _____  LEPC: Yes ___ No ___ Date: _____ Time: _____						
<b>Other Notification:</b> <table style="width: 100%; border: none;"> <tr> <td style="width: 35%; border: none;">Department/Command/Agency</td> <td style="width: 15%; border: none;">Date</td> <td style="width: 15%; border: none;">Time</td> <td style="width: 15%; border: none;">Phone</td> <td style="width: 20%; border: none;">POC</td> </tr> </table>		Department/Command/Agency	Date	Time	Phone	POC
Department/Command/Agency	Date	Time	Phone	POC		

**APPENDIX D - WASTE MANAGEMENT AND DISPOSAL PLAN**

THIS PAGE INTENTIONALLY LEFT BLANK

TABLE D.1: WASTE MANAGEMENT AND DISPOSAL PLAN			
<b>1. Incident Name:</b>	<b>2. Operational Period (Date/Time):</b> From: _____ To: _____	<b>WASTE MANAGEMENT AND DISPOSAL PLAN</b>	
<b>SOLID WASTES Covered by Plan</b>			
<b>Type</b>	<b>Description</b>	<b>Est. Volume(s)</b>	
<input type="checkbox"/> Oiled Natural Inorganic (Dirt, Gravel, Etc.)			
<input type="checkbox"/> Oiled Natural Organic (Grass, Branches, Etc.)			
<input type="checkbox"/> Oiled Man-made Materials (PPE, Sorbents, Etc.)			
<input type="checkbox"/> Oil-contaminated Wildlife Carcasses			
<input type="checkbox"/> Other			
<b>Waste Stream:</b>	<b>Suspected HW?</b>	<b>HW Code(s):</b>	<b>Determined by:</b>
	<input type="checkbox"/> Yes <input type="checkbox"/> No		<input type="checkbox"/> User Knowledge? <input type="checkbox"/> Laboratory Analysis?
	<input type="checkbox"/> Yes <input type="checkbox"/> No		<input type="checkbox"/> User Knowledge? <input type="checkbox"/> Laboratory Analysis?
	<input type="checkbox"/> Yes <input type="checkbox"/> No		<input type="checkbox"/> User Knowledge? <input type="checkbox"/> Laboratory Analysis?
	<input type="checkbox"/> Yes <input type="checkbox"/> No		<input type="checkbox"/> User Knowledge? <input type="checkbox"/> Laboratory Analysis?
	<input type="checkbox"/> Yes <input type="checkbox"/> No		<input type="checkbox"/> User Knowledge? <input type="checkbox"/> Laboratory Analysis?
	<input type="checkbox"/> Yes <input type="checkbox"/> No		<input type="checkbox"/> User Knowledge? <input type="checkbox"/> Laboratory Analysis?
Comments:			
WASTE MANAGEMENT AND DISPOSAL PLAN		Page 1 of ____	

TABLE D.1: WASTE MANAGEMENT AND DISPOSAL PLAN			
<b>LIQUID WASTES Covered by Plan</b>			
<b>Type</b>	<b>Description</b>	<b>Est. Volume(s)</b>	
<input type="checkbox"/> Oil / Water Mixtures			
<input type="checkbox"/> Reclaimable Petroleum	Products: <input type="checkbox"/> JP-5, <input type="checkbox"/> F-24, <input type="checkbox"/> F-76, <input type="checkbox"/> _____		
<input type="checkbox"/> Waste Water			
<input type="checkbox"/> Decontamination Liquids			
<input type="checkbox"/> Other			
<b>Waste Stream:</b>	<b>Suspected HW?</b>	<b>HW Code(s):</b>	<b>Determined by:</b>
	<input type="checkbox"/> Yes <input type="checkbox"/> No		<input type="checkbox"/> User Knowledge? <input type="checkbox"/> Laboratory Analysis?
	<input type="checkbox"/> Yes <input type="checkbox"/> No		<input type="checkbox"/> User Knowledge? <input type="checkbox"/> Laboratory Analysis?
	<input type="checkbox"/> Yes <input type="checkbox"/> No		<input type="checkbox"/> User Knowledge? <input type="checkbox"/> Laboratory Analysis?
	<input type="checkbox"/> Yes <input type="checkbox"/> No		<input type="checkbox"/> User Knowledge? <input type="checkbox"/> Laboratory Analysis?
	<input type="checkbox"/> Yes <input type="checkbox"/> No		<input type="checkbox"/> User Knowledge? <input type="checkbox"/> Laboratory Analysis?
	<input type="checkbox"/> Yes <input type="checkbox"/> No		<input type="checkbox"/> User Knowledge? <input type="checkbox"/> Laboratory Analysis?
Comments:			
WASTE MANAGEMENT AND DISPOSAL PLAN		Page ___ of ___	



TABLE D.1: WASTE MANAGEMENT AND DISPOSAL PLAN		
<b>Samples</b> <i>(If no samples to be taken, check box: <input type="checkbox"/> and explain in comments below)</i>		
Media to be sample:		
Laboratory Name(s):		
Sampling / Analysis Plan Attached? <input type="checkbox"/> Yes <input type="checkbox"/> No		
Comments:		
<b>Temporary Waste Storage</b>		
Waste Stream	Storage Container Type	Estimated Capacity / Number Required
<b>Storage Locations</b>		
Preferred Location, Site Manager	Ground/Runoff Protection Required for Storage Area?	Liners/Cover Protection Required for Storage?
	<input type="checkbox"/> Yes <input type="checkbox"/> No	<input type="checkbox"/> Yes <input type="checkbox"/> No
	<input type="checkbox"/> Yes <input type="checkbox"/> No	<input type="checkbox"/> Yes <input type="checkbox"/> No
	<input type="checkbox"/> Yes <input type="checkbox"/> No	<input type="checkbox"/> Yes <input type="checkbox"/> No
	<input type="checkbox"/> Yes <input type="checkbox"/> No	<input type="checkbox"/> Yes <input type="checkbox"/> No
	<input type="checkbox"/> Yes <input type="checkbox"/> No	<input type="checkbox"/> Yes <input type="checkbox"/> No
Comments:		
WASTE MANAGEMENT AND DISPOSAL PLAN		Page ___ of ___



<b>TABLE D.1: WASTE MANAGEMENT AND DISPOSAL PLAN</b>			
<b>Waste Transportation</b>			
Waste Stream:	Is Waste a DOT HM?	Waste Transportation Method	Transportation Resource
	<input type="checkbox"/> Yes <input type="checkbox"/> No		
	<input type="checkbox"/> Yes <input type="checkbox"/> No		
	<input type="checkbox"/> Yes <input type="checkbox"/> No		
	<input type="checkbox"/> Yes <input type="checkbox"/> No		
	<input type="checkbox"/> Yes <input type="checkbox"/> No		
	<input type="checkbox"/> Yes <input type="checkbox"/> No		
	<input type="checkbox"/> Yes <input type="checkbox"/> No		
	<input type="checkbox"/> Yes <input type="checkbox"/> No		
	<input type="checkbox"/> Yes <input type="checkbox"/> No		
	<input type="checkbox"/> Yes <input type="checkbox"/> No		
Permits Required for Disposal:			
Comments:			
WASTE MANAGEMENT AND DISPOSAL PLAN		Page ___ of ___	

THIS PAGE INTENTIONALLY LEFT BLANK.





**APPENDIX E - SAFETY DATA SHEETS**

THIS PAGE INTENTIONALLY LEFT BLANK



# Safety Data Sheet

## Jet Fuel

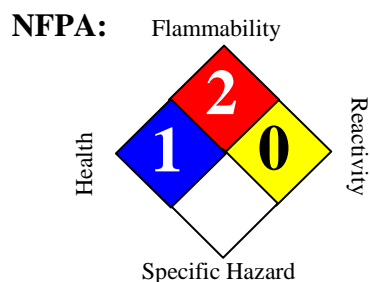

### SECTION 1. PRODUCT AND COMPANY IDENTIFICATION

<b>Product name</b>	:	Jet Fuel			
<b>Synonyms</b>	:	Jet Fuel - A, B, A-I, A-50, High Sulfur, Military, Jet A & B Aviation Turbine Fuel, Jet A-I, Jet A; Avjet For Blending; Jet Q Turbine Fuel, Aviation Fuel; Turbine Fuel; JP-4; JP-5; JP-8, Av-Jet, 888100004452			
<b>SDS Number</b>	:	888100004452	<b>Version</b>	:	2.15
<b>Product Use Description</b>	:	Fuel			
<b>Company</b>	:	For: Tesoro Refining & Marketing Co. 19100 Ridgewood Parkway, San Antonio, TX 78259			
<b>Tesoro Call Center</b>	:	(877) 783-7676	<b>Chemtrec (Emergency Contact)</b>	:	(800) 424-9300

### SECTION 2. HAZARDS IDENTIFICATION

<b>Classifications</b>	:	Flammable Liquid – Category 3 Aspiration Hazard – Category 1 Skin Irritation – Category 2 Specific Target Organ Toxicity (Single Exposure) – Category 3 Chronic Aquatic Toxicity – Category 2
<b>Pictograms</b>	:	
<b>Signal Word</b>	:	<b>Danger</b>
<b>Hazard Statements</b>	:	Flammable liquid and vapor. May be fatal if swallowed and enters airways – do not siphon by mouth. Causes skin irritation. Repeated or prolonged skin contact can cause skin irritation and dermatitis. May cause drowsiness or dizziness by inhalation. May cause irritation of respiratory system. Toxic to aquatic life with long lasting effects.
<b>Precautionary statements</b>	:	

<b>Prevention</b>	<p>Keep away from heat, sparks, open flames, welding and hot surfaces.          No smoking.          Keep container tightly closed.          Ground and/or bond container and receiving equipment.          Use explosion-proof electrical equipment.          Use only non-sparking tools if tools are used in flammable atmosphere.          Take precautionary measures against static discharge.          Wear gloves, eye protection and face protection as needed to prevent skin and eye contact with liquid.          Wash hands or liquid-contacted skin thoroughly after handling.          Do not eat, drink or smoke when using this product.          Do not breathe vapors or mists.          Use only outdoors or in a well-ventilated area.</p>
<b>Response</b>	<p>In case of fire: Use dry chemical, CO<sub>2</sub>, water spray or fire fighting foam to extinguish.          If swallowed: Immediately call a poison center, doctor, hospital emergency room, medical clinic or 911. Do NOT induce vomiting. Rinse mouth.          If skin irritation persists, get medical attention.          If inhaled: Remove person to fresh air and keep comfortable for breathing.          Get medical attention if you feel unwell.</p>
<b>Storage</b>	<p>Store in a well ventilated place. Keep cool. Store locked up. Keep container tightly closed . Use only approved containers.</p>
<b>Disposal</b>	<p>Dispose of contents/containers to approved disposal site in accordance with local, regional, national, and/or international regulations.</p>

### SECTION 3. COMPOSITION/INFORMATION ON INGREDIENTS

Component	CAS-No.	Weight %
Kerosene (petroleum)	8008-20-6	100%
Naphthalene	91-20-3	0 to 3%
Ethyl Benzene	100-41-4	0 to 1%
Trimethy Benzene	95-63-6	0 to 1%
Ethyl Benzene	100-41-4	0 to 1%

### SECTION 4. FIRST AID MEASURES

<b>Inhalation</b>	: If inhaled, remove to fresh air. If not breathing, give artificial respiration. If necessary, provide additional oxygen once breathing is restored if trained to do so. Seek medical attention immediately.
<b>Skin contact</b>	: Take off all contaminated clothing immediately. Wash off immediately with soap and plenty of water. Wash contaminated clothing before re-use. If skin irritation persists, seek medical attention.
<b>Eye contact</b>	: In case of eye contact, remove contact lens and rinse immediately with plenty of water, also under the eyelids, for at least 15 minutes. Seek medical attention

	immediately.
<b>Ingestion</b>	: Do NOT induce vomiting. Do not give liquids. Seek medical attention immediately. If vomiting does occur naturally, keep head below the hips to reduce the risks of aspiration. Monitor for breathing difficulties. Small amounts of material which enter the mouth should be rinsed out until the taste is dissipated.
<b>Notes to physician</b>	: Symptoms: Aspiration may cause pulmonary edema and pneumonitis. Treatment: Do not induce vomiting, use gastric lavage only. Remove from further exposure and treat symptomatically.

## SECTION 5. FIRE-FIGHTING MEASURES

<b>Suitable extinguishing media</b>	: Carbon dioxide (CO <sub>2</sub> ), Water spray, Dry chemical, Foam, Keep containers and surroundings cool with water spray., Do not use a solid water stream as it may scatter and spread fire., Water may be ineffective for fighting the fire, but may be used to cool fire-exposed containers.
<b>Specific hazards during fire fighting</b>	: Fire Hazard. Do not use a solid water stream as it may scatter and spread fire. Cool closed containers exposed to fire with water spray. Sealed containers may rupture when heated. Above the flash point, explosive vapor-air mixtures may be formed. Vapors can flow along surfaces to distant ignition source and flash back.
<b>Special protective equipment for fire-fighters</b>	: Firefighting activities that may result in potential exposure to high heat, smoke or toxic by-products of combustion should require NIOSH/MSHA- approved pressure-demand self-contained breathing apparatus with full facepiece and full protective clothing.
<b>Further information</b>	: Exposure to decomposition products may be a hazard to health. Standard procedure for chemical fires.

## SECTION 6. ACCIDENTAL RELEASE MEASURES

<b>Personal precautions</b>	: ACTIVATE FACILITY'S SPILL CONTINGENCY OR EMERGENCY RESPONSE PLAN if applicable. Evacuate nonessential personnel and remove or secure all ignition sources. Consider wind direction; stay upwind and uphill, if possible. Evaluate the direction of product travel, diking, sewers, etc. to contain spill areas. Spills may infiltrate subsurface soil and groundwater; professional assistance may be necessary to determine the extent of subsurface impact.
<b>Environmental precautions</b>	: Carefully contain and stop the source of the spill, if safe to do so. Protect bodies of water by diking, absorbents, or absorbent boom, if possible. Do not flush down sewer or drainage systems, unless system is designed and permitted to handle such material. The use of fire fighting foam may be useful in certain situations to reduce vapors. The proper use of water spray may effectively disperse product vapors or the liquid itself, preventing contact with ignition sources or areas/equipment that require protection.
<b>Methods for cleaning up</b>	: Take up with sand or oil absorbing materials. Carefully shovel, scoop or sweep up into a waste container for reclamation or disposal - caution, flammable vapors may accumulate in closed containers. Response and clean-up crews must be properly trained and must utilize proper protective equipment (see Section 8).

## SECTION 7. HANDLING AND STORAGE

<b>Precautions for safe handling</b>	: Keep away from fire, sparks and heated surfaces. No smoking near areas where
--------------------------------------	--

material is stored or handled. The product should only be stored and handled in areas with intrinsically safe electrical classification.

- : Hydrocarbon liquids including this product can act as a non-conductive flammable liquid (or static accumulators), and may form ignitable vapor-air mixtures in storage tanks or other containers. Precautions to prevent static-initated fire or explosion during transfer, storage or handling, include but are not limited to these examples:
  - (1) Ground and bond containers during product transfers. Grounding and bonding may not be adequate protection to prevent ignition or explosion of hydrocarbon liquids and vapors that are static accumulators.
  - (2) Special slow load procedures for "switch loading" must be followed to avoid the static ignition hazard that can exist when higher flash point material (such as fuel oil or diesel) is loaded into tanks previously containing low flash point products (such as gasoline or naphtha).
  - (3) Storage tank level floats must be effectively bonded.

For more information on precautions to prevent static-initated fire or explosion, see NFPA 77, Recommended Practice on Static Electricity (2007), and API Recommended Practice 2003, Protection Against Ignitions Arising Out of Static, Lightning, and Stray Currents (2008).

#### Conditions for safe storage, including incompatibilities

- : Keep away from flame, sparks, excessive temperatures and open flame. Use approved containers. Keep containers closed and clearly labeled. Empty or partially full product containers or vessels may contain explosive vapors. Do not pressurize, cut, heat, weld or expose containers to sources of ignition. Store in a well-ventilated area. The storage area should comply with NFPA 30 "Flammable and Combustible Liquid Code". The cleaning of tanks previously containing this product should follow API Recommended Practice (RP) 2013 "Cleaning Mobile Tanks In Flammable and Combustible Liquid Service" and API RP 2015 "Cleaning Petroleum Storage Tanks".
- : Keep away from food, drink and animal feed. Incompatible with oxidizing agents. Incompatible with acids.
- : Emergency eye wash capability should be available in the near proximity to operations presenting a potential splash exposure.

## SECTION 8. EXPOSURE CONTROLS / PERSONAL PROTECTION

### Exposure Guidelines

List	Components	CAS-No.	Type:	Value
OSHA Z1	Naphthalene	91-20-3	PEL	10 ppm 50 mg/m3
	Ethyl Benzene	100-41-4	PEL	100 ppm 435 mg/m3
ACGIH	Naphthalene	91-20-3	TWA	10 ppm
		91-20-3	STEL	15 ppm
	Kerosene (petroleum)	8008-20-6	TWA	200 mg/m3
	Ethyl Benzene	100-41-4	TWA	100 ppm 434 mg/m3
			STEL	125 ppm 543 mg/m3

**Protective measures** : Keep out of reach of children.

**Engineering measures** : Use only intrinsically safe electrical equipment approved for use in classified areas. Emergency eye wash capability should be available in the vicinity of any potential

	splash exposure.
<b>Eye protection</b>	: Goggles and face shield as needed to prevent eye and face contact.
<b>Hand protection</b>	: Gloves constructed of nitrile, neoprene, or PVC are recommended.
<b>Skin and body protection</b>	: Chemical protective clothing such as DuPont TyChem®, Barricade or equivalent, recommended based on degree of exposure. Consult manufacturer specifications for further information.
<b>Respiratory protection</b>	: NIOSH/MSHA approved positive-pressure self-contained breathing apparatus (SCBA) or Type C positive-pressure supplied air with escape bottle must be used for gas concentrations above occupational exposure limits, for potential of uncontrolled release, if exposure levels are not known, or in an oxygen-deficient atmosphere.
<b>Work / Hygiene practices</b>	: Emergency eye wash capability should be available in the near proximity to operations presenting a potential splash exposure. Use good personal hygiene practices. Avoid repeated and/or prolonged skin exposure. Wash hands before eating, drinking, smoking, or using toilet facilities. Do not use as a cleaning solvent on the skin. Do not use solvents or harsh abrasive skin cleaners for washing this product from exposed skin areas. Waterless hand cleaners are effective. Promptly remove contaminated clothing and launder before reuse. Use care when laundering to prevent the formation of flammable vapors which could ignite via washer or dryer. Consider the need to discard contaminated leather shoes and gloves.

## SECTION 9. PHYSICAL AND CHEMICAL PROPERTIES

<b>Appearance</b>	: Clear to straw colored liquid
<b>Odor</b>	Characteristic petroleum or kerosene-like odor
<b>Odor threshold</b>	0.1 - 1 ppm typically reported
<b>pH</b>	Not applicable
<b>Melting point/freezing point</b>	Gel point can be about -15°F; freezing requires laboratory conditions
<b>Initial boiling point &amp; range</b>	154 - 372 °C (310° - 702 °F)
<b>Flash point</b>	38°C (100°F) Minimum
<b>Evaporation rate</b>	Higher initially and declining as lighter components evaporate
<b>Flammability (solid, gas)</b>	Flammable vapor released by liquid
<b>Upper explosive limit</b>	5.0 %(V)
<b>Lower explosive limit</b>	0.7 %(V)
<b>Vapor pressure</b>	< 2 mm Hg at 20 °C
<b>Vapor density (air = 1)</b>	> 4.5 0.8 g/mL
<b>Relative density (water = 1)</b>	0.0005 g/100 mL
<b>Solubility (in water)</b>	3.3 to 6 as log Pow

Partition coefficient (n-octanol/water)	210 °C (410°F)	
Auto-ignition temperature	Will evaporate or boil and possibly ignite before decomposition occurs.	
Decomposition temperature	1.6 mm <sup>2</sup> /s at 40°C	
Kinematic viscosity		
Conductivity (conductivity can be reduced by environmental factors such as a decrease in temperature)	Diesel Fuel Oils at terminal load rack:	At least 25 pS/m
	Ultra Low Sulfur Diesel (ULSD) without conductivity additive:	0 pS/m to 5 pS/m
	ULSD at terminal load rack with conductivity additive:	At least 50 pS/m
	JP-8 at terminal load rack:	150 pS/m to 600 pS/m

## SECTION 10. STABILITY AND REACTIVITY

Reactivity	: Vapors may form explosive mixture with air. Hazardous polymerization does not occur.
Chemical stability	: Stable under normal conditions.
Possibility of hazardous reactions	Can react with strong oxidizing agents, peroxides, acids and alkalies.
Conditions to avoid	: Avoid high temperatures, open flames, sparks, welding, smoking and other ignition sources. Avoid static charge accumulation and discharge (see Section 7).
Hazardous decomposition products	: Ignition and burning can release carbon monoxide, carbon dioxide, non-combusted hydrocarbons (smoke) and, depending on formulation, trace amounts of sulfur dioxide. Diesel exhaust particulates may be a lung hazard (see Section 11).

## SECTION 11. TOXICOLOGICAL INFORMATION

Skin irritation	: Irritating to skin. Repeated or prolonged contact can cause dryness, cracking and dermatitis. Liquid may be absorbed through skin in toxic amounts if large areas of the skin are repeatedly exposed.
Eye irritation	: May cause eye irritation.
Inhalation	Inhalation of vapors or mist may result in respiratory tract irritation and central nervous system effects including headache, dizziness, loss of balance and coordination, unconsciousness, coma, respiratory failure and death.
Chronic Exposure	Similar products produced skin cancer and systemic toxicity in laboratory animals following repeated applications. The significance of these results to human exposure has not been determined.
Further information	: Kerosene does not have a measurable effect on human reproduction or development. Kerosene is not listed as carcinogenic by NTP, OSHA, and ACGIH. IARC has listed kerosene as a probable human carcinogen. Some petroleum distillates have been found to cause adverse reproductive effects in laboratory animals. Acute and chronic exposure to kerosene may result in CNS effects including irritability, restlessness, ataxia, drowsiness, convulsions, coma and death. The most common health effect associated with chronic kerosene exposure is dermatitis.

**Component:**

<b>Kerosene (petroleum)</b>	8008-20-6	<u>Acute oral toxicity:</u> LD50 rat 4 hour Dose: >5,000 mg/kg <u>Acute dermal toxicity:</u> LD50 rabbit Dose: >2,001 mg/kg  <u>Acute inhalation toxicity:</u> LC50 rat Dose: >5,000 mg/l Exposure time: 4 h  <u>Skin irritation:</u> Classification: Irritating to skin. Result: Skin irritation
<b>Naphthalene</b>	91-20-3	<u>Acute oral toxicity:</u> LD50 rat Dose: 2,001 mg/kg  <u>Acute dermal toxicity:</u> LD50 rat Dose: 2,501 mg/kg  <u>Acute inhalation toxicity:</u> LC50 rat Dose: 101 mg/l Exposure time: 4 h  <u>Skin irritation:</u> Classification: Irritating to skin. Result: Mild skin irritation  <u>Eye irritation:</u> Classification: Irritating to eyes. Result: Mild eye irritation  <u>Carcinogenicity:</u> N11.00422130

**Carcinogenicity**

<b>NTP</b>	Naphthalene (CAS-No.: 91-20-3)
<b>IARC</b>	Kerosene is not listed as carcinogenic by NTP, OSHA, and ACGIH. IARC has listed kerosene as a probable human carcinogen. naphthalene (CAS-No.: 91-20-3) Kerosene (petroleum) (CAS-No.: 8008-20-6)
<b>CA Prop 65</b>	WARNING! This product contains a chemical known to the State of California to cause cancer. Naphthalene (CAS-No.: 91-20-3)

**SECTION 12. ECOLOGICAL INFORMATION**

**Additional ecological information** : Release of this product should be prevented from contaminating soil and water and from entering drainage and sewer systems. U.S.A. regulations require reporting spills of this material that could reach any surface waters. The toll free number for the U.S. Coast Guard National Response Center is (800) 424-8802. Naphthalene (91-20-3) one of the ingredients in this mixture is classified as a Marine Pollutant.

**Component:**

<b>Naphthalene</b>	91-20-3	<u>Toxicity to algae:</u> EC50 Species: Dose: 33 mg/l Exposure time: 24 h
--------------------	---------	---

**SECTION 13. DISPOSAL CONSIDERATIONS**

**Disposal** : Whatever cannot be saved for recovery or recycling should be handled as hazardous waste and sent to a RCRA approved waste facility. Processing, use or contamination of this product may change the waste management options. State and local disposal regulations may differ from federal disposal regulations. Dispose of container and unused contents in accordance with federal, state and local requirements.

## SECTION 14. TRANSPORT INFORMATION

### CFR

Proper shipping name : Fuel, aviation, turbine engine  
 UN-No. : 1863  
 Class : 3  
 Packing group : III

### TDG

Proper shipping name : Fuel, aviation, turbine engine  
 UN-No. : UN1863  
 Class : 3  
 Packing group : III

### IATA Cargo Transport

UN UN-No. : UN1863  
 Description of the goods : Fuel, aviation, turbine engine  
 Class : 3  
 Packaging group : III  
 ICAO-Labels : 3  
 Packing instruction (cargo aircraft) : 366  
 Packing instruction (cargo aircraft) : Y344

### IATA Passenger Transport

UN UN-No. : UN1863  
 Description of the goods : Fuel, aviation, turbine engine  
 Class : 3  
 Packaging group : III  
 ICAO-Labels : 3  
 Packing instruction (passenger aircraft) : 355  
 Packing instruction (passenger aircraft) : Y344

### IMDG-Code

UN-No. : UN 1863  
 Description of the goods : Fuel, aviation, turbine engine  
 Class : 3  
 Packaging group : III  
 IMDG-Labels : 3  
 EmS Number : F-E S-E  
 Marine pollutant : Yes



**SECTION 15. REGULATORY INFORMATION**

TSCA Status	: On TSCA Inventory
DSL Status	: All components of this product are on the Canadian DSL list.
SARA 311/312 Hazards	: Acute Health Hazard Chronic Health Hazard Fire Hazard

**CERCLA SECTION 103 and SARA SECTION 304 (RELEASE TO THE ENVIROMENT)**

The CERCLA definition of hazardous substances contains a "petroleum exclusion" clause which exempts crude oil. Fractions of crude oil, and products (both finished and intermediate) from the crude oil refining process and any indigenous components of such from the CERCLA Section 103 reporting requirements. However, other federal reporting requirements, including SARA Section 304, as well as the Clean Water Act may still apply.

California Prop. 65	: WARNING! This product contains a chemical known to the State of California to cause cancer.
---------------------	---

Naphthalene

91-20-3

**SECTION 16. OTHER INFORMATION**Further information

The information provided in this Safety Data Sheet is correct to the best of our knowledge, information and belief at the date of its publication. The information given is designed only as guidance for safe handling, use, processing, storage, transportation, disposal and release and is not to be considered a warranty or quality specification. The information relates only to the specific material designated and may not be valid for such material used in combination with any other materials or in any process, unless specified in the text.

**Revision Date** : 11/17/2012

40, 41, 42, 43, 139, 141, 263, 1117, 1333, 1450, 1640

THIS PAGE INTENTIONALLY LEFT BLANK

# Material Safety Data Sheet

## Diesel Fuel - High Sulfur

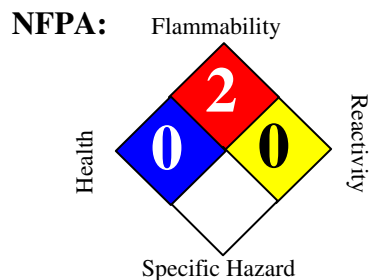

**HMIS III:**

HEALTH	1
FLAMMABILITY	2
PHYSICAL	0

0 = Insignificant, 1 = Slight, 2 = Moderate, 3 = High, 4 = Extreme

### SECTION 1. PRODUCT AND COMPANY IDENTIFICATION

<b>Product name</b>	: Diesel Fuel - High Sulfur		
<b>Synonyms</b>	: Heating Oil, Gas Oil Light Straight Run, High Sulfur Diesel Fuel #1, High Sulfur Diesel Fuel #2, Marine Diesel Fuel, F76, 888100004572		
<b>MSDS Number</b>	: 888100004572	<b>Version</b>	: 2.8
<b>Product Use Description</b>	: Fuel		
<b>Company</b>	: For: Tesoro Refining & Marketing Co. 19100 Ridgewood Parkway, San Antonio, TX 78259		
<b>Tesoro Call Center</b>	: (877) 783-7676	<b>Chemtrec (Emergency Contact)</b>	: (800) 424-9300

### SECTION 2. HAZARDS IDENTIFICATION

#### Emergency Overview

<b>Regulatory status</b>	: This material is considered hazardous by the Occupational Safety and Health Administration (OSHA) Hazard Communication Standard (29 CFR 1910.1200).
<b>Signal Word</b>	: WARNING
<b>Hazard Summary</b>	: Combustible Liquid

Toxic

#### Potential Health Effects

<b>Inhalation</b>	: Vapors or mists from this material can irritate the nose, throat, and lungs, and can cause signs and symptoms of central nervous system depression, depending on the concentration and duration of exposure.
<b>Eyes</b>	: Eye irritation may result from contact with liquid, mists, and/or vapors.
<b>Skin</b>	: Skin irritation leading to dermatitis may occur upon prolonged or repeated contact. Liquid may be absorbed through the skin in toxic amounts if large areas of skin are repeatedly exposed. Long-term, repeated skin contact may cause skin cancer.
<b>Ingestion</b>	: Harmful or fatal if swallowed. Do NOT induce vomiting. This material can irritate the mouth, throat, stomach, and cause nausea, vomiting, diarrhea and restlessness. Aspiration hazard if liquid is inhaled into lungs, particularly from vomiting after ingestion. Aspiration may result in chemical pneumonia, severe

lung damage, respiratory failure and even death.

**Target Organs**

: Kidney, Liver, Central nervous system, Eyes, Skin

<b>Fuels, diesel, No 2; Gasoil - unspecified</b>	68476-34-6	100%
<b>Naphthalene</b>	91-20-3	1 - 5%
<b>Xylene</b>	1330-20-7	1 - 5%
<b>Nonane</b>	111-84-2	0.75 - 1%
<b>1,2,4-Trimethylbenzene</b>	95-63-6	0.75 - 1%
<b>Sulfur</b>	7704-34-9	0.5% Maximum

**SECTION 4. FIRST AID MEASURES**

- Inhalation** : Move to fresh air. Give oxygen. If breathing is irregular or stopped, administer artificial respiration. Seek medical attention immediately.
- Skin contact** : Take off all contaminated clothing immediately. Wash off immediately with soap and plenty of water. Wash contaminated clothing before re-use. If skin irritation persists, seek medical attention.
- Eye contact** : Remove contact lenses. Rinse immediately with plenty of water, also under the eyelids, for at least 15 minutes. If eye irritation persists, seek medical attention.
- Ingestion** : Do NOT induce vomiting. Ingestion may result in nausea, vomiting, diarrhea and restlessness. Aspiration may cause pulmonary edema and pneumonitis. Seek medical attention immediately.
- Notes to physician** : Symptoms: Dizziness, Discomfort, Headache, Nausea, Disorder, Vomiting, Lung edema, Aspiration may cause pulmonary edema and pneumonitis. Liver disorders, Kidney disorders.

**SECTION 5. FIRE-FIGHTING MEASURES**

- Form** : Liquid
- Flash point** : 38 °C (100 °F) Minimum for #1 Diesel ; 52°C Minimum for #2 Diesel
- Lower explosive limit** : 0.7 %(V)
- Upper explosive limit** : 5 %(V)
- Suitable extinguishing media** : Carbon dioxide (CO2), Water spray, Dry chemical, Foam, Keep containers and surroundings cool with water spray.
- Specific hazards during fire fighting** : Fire Hazard Do not use a solid water stream as it may scatter and spread fire. Cool closed containers exposed to fire with water spray.

- Special protective equipment for fire-fighters** : Wear self-contained breathing apparatus and protective suit. Use personal protective equipment.
- Further information** : Exposure to decomposition products may be a hazard to health. Isolate area around container involved in fire. Cool tanks, shells, and containers exposed to fire and excessive heat with water. For massive fires the use of unmanned hose holders or monitor nozzles may be advantageous to further minimize personnel exposure. Major fires may require withdrawal, allowing the tank to burn. Large storage tank fires typically require specially trained personnel and equipment to extinguish the fire, often including the need for properly applied fire fighting foam.

**SECTION 6. ACCIDENTAL RELEASE MEASURES**

- Personal precautions** : Consider wind direction; stay upwind and uphill, if possible. Evacuate nonessential personnel and remove or secure all ignition sources. Evaluate the direction of product travel, diking, sewers, etc. to contain spill areas. Spills may infiltrate subsurface soil and groundwater; professional assistance may be necessary to determine the extent of subsurface impact. Ensure adequate ventilation. Use personal protective equipment.
- Environmental precautions** : Carefully contain and stop the source of the spill, if safe to do so. Do not flush down sewer or drainage systems, unless system is designed and permitted to handle such material. The use of fire fighting foam may be useful in certain situations to reduce vapors. The proper use of water spray may effectively disperse product vapors or the liquid itself, preventing contact with ignition sources or areas/equipment that require protection. Discharge into the environment must be avoided. If the product contaminates rivers and lakes or drains inform respective authorities.
- Methods for cleaning up** : Take up with sand or oil absorbing materials. Carefully shovel, scoop or sweep up into a waste container for reclamation or disposal - caution, flammable vapors may accumulate in closed containers. Response and clean-up crews must be properly trained and must utilize proper protective equipment (see Section 8).

**SECTION 7. HANDLING AND STORAGE**

- Handling** : Keep away from fire, sparks and heated surfaces. No smoking near areas where material is stored or handled. The product should only be stored and handled in areas with intrinsically safe electrical classification.
- Advice on protection against fire and explosion** : Hydrocarbon liquids including this product can act as a non-conductive flammable liquid (or static accumulators), and may form ignitable vapor-air mixtures in storage tanks or other containers. Precautions to prevent static-initated fire or explosion during transfer, storage or handling, include but are not limited to these examples:
- (1) Ground and bond containers during product transfers. Grounding and bonding may not be adequate protection to prevent ignition or explosion of hydrocarbon liquids and vapors that are static accumulators.
  - (2) Special slow load procedures for "switch loading" must be followed to avoid the static ignition hazard that can exist when higher flash point material (such as fuel oil or diesel) is loaded into tanks previously containing low flash point products (such as gasoline or naphtha).
  - (3) Storage tank level floats must be effectively bonded.
- For more information on precautions to prevent static-initated fire or explosion, see NFPA 77, Recommended Practice on Static Electricity (2007), and API

Recommended Practice 2003, Protection Against Ignitions Arising Out of Static, Lightning, and Stray Currents (2008).

- Dust explosion class** : Not applicable
- Requirements for storage areas and containers** : Keep away from flame, sparks, excessive temperatures and open flame. Use approved containers. Keep containers closed and clearly labeled. Empty or partially full product containers or vessels may contain explosive vapors. Do not pressurize, cut, heat, weld or expose containers to sources of ignition. Store in a well-ventilated area. The storage area should comply with NFPA 30 "Flammable and Combustible Liquid Code". The cleaning of tanks previously containing this product should follow API Recommended Practice (RP) 2013 "Cleaning Mobile Tanks In Flammable and Combustible Liquid Service" and API RP 2015 "Cleaning Petroleum Storage Tanks".
- Advice on common storage** : Keep away from food, drink and animal feed. Incompatible with oxidizing agents. Incompatible with acids.
- Other data** : No decomposition if stored and applied as directed.

**SECTION 8. EXPOSURE CONTROLS / PERSONAL PROTECTION**

**Exposure Guidelines**

List	Components	CAS-No.	Type:	Value
<b>OSHA Z1</b>	Naphthalene	91-20-3	PEL	10 ppm 50 mg/m3
	Xylene	1330-20-7	PEL	100 ppm 435 mg/m3
<b>ACGIH</b>	Diesel Fuel	68476-30-2	TWA	100 mg/m3
<b>ACGIH</b>	Naphthalene	91-20-3	TWA	10 ppm
		91-20-3	STEL	15 ppm
	Xylene	1330-20-7	TWA	100 ppm
		1330-20-7	STEL	150 ppm
	Nonane	111-84-2	TWA	200 ppm

- Engineering measures** : Use only intrinsically safe electrical equipment approved for use in classified areas.
- Eye protection** : Safety glasses with side-shields reference to 29 CFR 1910.133
- Hand protection** : Gloves constructed of nitrile, neoprene, or PVC are recommended. Consult manufacturer specifications for further information.
- Skin and body protection** : If needed to prevent skin contact, chemical protective clothing such as of DuPont TyChem®, Saranex or equivalent recommended based on degree of exposure. The resistance of specific material may vary from product to product as well as with degree of exposure.

- Respiratory protection** : A NIOSH/ MSHA-approved air-purifying respirator with organic vapor cartridges or canister may be permissible under certain circumstances where airborne concentrations are or may be expected to exceed exposure limits or for odor or irritation. Protection provided by air-purifying respirators is limited. Refer to OSHA 29 CFR 1910.134, ANSI Z88.2-1992, NIOSH Respirator Decision Logic, and the manufacturer for additional guidance on respiratory protection selection. NIOSH/MSHA approved positive-pressure self-contained breathing apparatus (SCBA) or Type C positive-pressure supplied air with escape bottle must be used for gas concentrations above occupational exposure limits, for potential of uncontrolled release, if exposure levels are not known, or in an oxygen-deficient atmosphere.
- Work / Hygiene practices** : Emergency eye wash capability should be available in the near proximity to operations presenting a potential splash exposure. Use good personal hygiene practices. Avoid repeated and/or prolonged skin exposure. Wash hands before eating, drinking, smoking, or using toilet facilities. Do not use as a cleaning solvent on the skin. Do not use solvents or harsh abrasive skin cleaners for washing this product from exposed skin areas. Waterless hand cleaners are effective. Promptly remove contaminated clothing and launder before reuse. Use care when laundering to prevent the formation of flammable vapors which could ignite via washer or dryer. Consider the need to discard contaminated leather shoes and gloves.

**SECTION 9. PHYSICAL AND CHEMICAL PROPERTIES**

<b>Form</b>	: Liquid										
<b>Appearance</b>	: Clear, straw colored										
<b>Odor</b>	: Characteristic petroleum (kerosene) odor										
<b>Flash point</b>	: 38 °C (100 °F) Minimum for #1 Diesel ; 52 °C Minimum for #2 Diesel										
<b>Thermal decomposition</b>	: No decomposition if stored and applied as directed.										
<b>Lower explosive limit</b>	: 0.7 %(V)										
<b>Upper explosive limit</b>	: 5 %(V)										
<b>Freezing point</b>	: Not applicable										
<b>Boiling point</b>	: 160 °C(320 °F)										
<b>Vapor Pressure</b>	: <2mm Hg at 20 °C at 20 °C (68 °F)										
<b>Relative Vapor Density</b>	: 5.7 (Air = 1.0)										
<b>Water solubility</b>	: Negligible										
<b>Percent Volatiles</b>	: 100 %										
<b>Conductivity (conductivity can be reduced by environmental factors such as a decrease in temperature)</b>	<table border="0"> <tr> <td>Diesel Fuel Oils at terminal load rack:</td> <td>At least 25 pS/m</td> </tr> <tr> <td>Ultra Low Sulfur Diesel (ULSD) without conductivity additive:</td> <td>0 pS/m to 5 pS/m</td> </tr> <tr> <td>ULSD at terminal load rack with conductivity additive:</td> <td>At least 50 pS/m but</td> </tr> <tr> <td>conductivity may decrease from environmental factors such as temperature drop.</td> <td></td> </tr> <tr> <td>JP-8 at terminal load rack:</td> <td>150 pS/m to 600 pS/m</td> </tr> </table>	Diesel Fuel Oils at terminal load rack:	At least 25 pS/m	Ultra Low Sulfur Diesel (ULSD) without conductivity additive:	0 pS/m to 5 pS/m	ULSD at terminal load rack with conductivity additive:	At least 50 pS/m but	conductivity may decrease from environmental factors such as temperature drop.		JP-8 at terminal load rack:	150 pS/m to 600 pS/m
Diesel Fuel Oils at terminal load rack:	At least 25 pS/m										
Ultra Low Sulfur Diesel (ULSD) without conductivity additive:	0 pS/m to 5 pS/m										
ULSD at terminal load rack with conductivity additive:	At least 50 pS/m but										
conductivity may decrease from environmental factors such as temperature drop.											
JP-8 at terminal load rack:	150 pS/m to 600 pS/m										

**SECTION 10. STABILITY AND REACTIVITY**

<b>Conditions to avoid</b>	: Avoid high temperatures, open flames, sparks, welding, smoking and other ignition sources. Keep away from strong oxidizers. Viton ® ; Fluorel ®
<b>Materials to avoid</b>	: Strong oxidizing agents Peroxides
<b>Hazardous decomposition products</b>	: Carbon monoxide, carbon dioxide and noncombusted hydrocarbons (smoke). Diesel exhaust particulates may be a lung hazard - see Section 11.
<b>Thermal decomposition</b>	: No decomposition if stored and applied as directed. No decomposition if used as directed.
<b>Hazardous reactions</b>	: Keep away from oxidizing agents, and acidic or alkaline products.

**SECTION 11. TOXICOLOGICAL INFORMATION**

**Carcinogenicity**

<b>NTP</b>	: Naphthalene (CAS-No.: 91-20-3)
<b>IARC</b>	: Naphthalene (CAS-No.: 91-20-3)
<b>OSHA</b>	: No component of this product which is present at levels greater than or equal to 0.1 % is identified as a carcinogen or potential carcinogen by OSHA.
<b>CA Prop 65</b>	: WARNING! This product contains a chemical known to the State of California to cause cancer. Naphthalene (CAS-No.: 91-20-3)
<b>Skin irritation</b>	: Irritating to skin.
<b>Eye irritation</b>	: Irritating to eyes.
<b>Further information</b>	: Studies have shown that similar products produce skin cancer or skin tumors in laboratory animals following repeated applications without washing or removal. The significance of this finding to human exposure has not been determined. Other studies with active skin carcinogens have shown that washing the animal's skin with soap and water between applications reduced tumor formation. Positive mutagenicity results have been reported. Repeated over-exposure may cause liver and kidney injury IARC classifies whole diesel fuel exhaust particulates as probably carcinogenic to humans (Group 2A). NIOSH regards whole diesel fuel exhaust particulates as a potential cause of occupational lung cancer based on animal studies and limited evidence in humans.

**Component:**

<b>Fuels, diesel, No 2; Gasoil - unspecified</b>	68476-34-6	<u>Acute oral toxicity:</u> LD50 rat Dose: 5,001 mg/kg
		<u>Acute dermal toxicity:</u> LD50 rabbit Dose: 2,001 mg/kg
		<u>Acute inhalation toxicity:</u> LC50 rat Dose: 7.64 mg/l Exposure time: 4 h
		<u>Skin irritation:</u> Classification: Irritating to skin. Result: Severe skin irritation
		<u>Eye irritation:</u> Classification: Irritating to eyes. Result: Mild eye irritation
<b>Naphthalene</b>	91-20-3	<u>Acute oral toxicity:</u> LD50 rat



Dose: 2,001 mg/kg

Acute dermal toxicity: LD50 rat  
Dose: 2,501 mg/kg

Acute inhalation toxicity: LC50 rat  
Dose: 101 mg/l  
Exposure time: 4 h

Skin irritation: Classification: Irritating to skin.  
Result: Mild skin irritation

Eye irritation: Classification: Irritating to eyes.  
Result: Mild eye irritation

Carcinogenicity: N11.00422130

**Xylene** 1330-20-7

Acute oral toxicity: LD50 rat  
Dose: 2,840 mg/kg

Acute dermal toxicity: LD50 rabbit  
Dose: ca. 4,500 mg/kg

Acute inhalation toxicity: LC50 rat  
Dose: 6,350 mg/l  
Exposure time: 4 h

Skin irritation: Classification: Irritating to skin.  
Result: Mild skin irritation

Repeated or prolonged exposure may cause skin irritation and dermatitis, due to degreasing properties of the product.

Eye irritation: Classification: Irritating to eyes.  
Result: Mild eye irritation

**Nonane** 111-84-2

Acute oral toxicity: LD50 mouse  
Dose: 218 mg/kg

Acute inhalation toxicity: LC50 rat  
Exposure time: 4 h

**1,2,4-Trimethylbenzene** 95-63-6

Acute inhalation toxicity: LC50 rat  
Dose: 18 mg/l  
Exposure time: 4 h

Skin irritation: Classification: Irritating to skin.  
Result: Skin irritation

Eye irritation: Classification: Irritating to eyes.  
Result: Eye irritation

**Sulfur** 7704-34-9

Acute oral toxicity: LD50 rat  
Dose: 5,001 mg/kg

Acute dermal toxicity: LD50 rabbit  
Dose: 2,001 mg/kg

Acute inhalation toxicity: LC50 rat  
Dose: 9.24 mg/l  
Exposure time: 4 h

Eye irritation: Classification: Irritating to eyes.  
Result: Mild eye irritation

**SECTION 12. ECOLOGICAL INFORMATION**

**Biochemical Oxygen Demand (BOD)** : No data available

**Chemical Oxygen Demand (COD)** : No data available

**Adsorbed organic bound halogens (AOX)** : Not included

**Additional ecological information** : Keep out of sewers, drainage areas, and waterways. Report spills and releases, as applicable, under Federal and State regulations.

**Component:**

**Naphthalene** 91-20-3 Toxicity to algae:  
 EC50  
 Species:  
 Dose: 33 mg/l  
 Exposure time: 24 h

**1,2,4-Trimethylbenzene** 95-63-6 Toxicity to fish:  
 LC50  
 Species: Pimephales promelas (fathead minnow)  
 Dose: 7.72 mg/l  
 Exposure time: 96 h

Acute and prolonged toxicity for aquatic invertebrates:  
 EC50  
 Species: Daphnia  
 Dose: 3.6 mg/l  
 Exposure time: 48 h

**Sulfur** 7704-34-9 Acute and prolonged toxicity for aquatic invertebrates:  
 EC0  
 Species: Daphnia magna (Water flea)  
 Dose: > 10,000 mg/l  
 Exposure time: 24 h

**SECTION 13. DISPOSAL CONSIDERATIONS**

**Disposal** : Consult federal, state and local waste regulations to determine appropriate waste characterization of material and allowable disposal methods.

**SECTION 14. TRANSPORT INFORMATION**

**CFR**

Proper shipping name : DIESEL FUEL  
 UN-No. : 1202 (NA 1993)  
 Class : 3  
 Packing group : III

**TDG**

Proper shipping name : DIESEL FUEL  
 UN-No. : UN1202 (NA 1993)  
 Class : 3  
 Packing group : III

**IATA Cargo Transport**

UN UN-No. : UN1202 (NA 1993)  
 Description of the goods : DIESEL FUEL  
 Class : 3  
 Packaging group : III

ICAO-Labels : 3  
 Packing instruction (cargo aircraft) : 366  
 Packing instruction (cargo aircraft) : Y344

**IATA Passenger Transport**

UN UN-No. : UN1202 (NA 1993)  
 Description of the goods : DIESEL FUEL  
 Class : 3  
 Packaging group : III  
 ICAO-Labels : 3  
 Packing instruction (passenger aircraft) : 355  
 Packing instruction (passenger aircraft) : Y344

**IMDG-Code**

UN-No. : UN 1202 (NA 1993)  
 Description of the goods : DIESEL FUEL  
 Class : 3  
 Packaging group : III  
 IMDG-Labels : 3  
 EmS Number : F-E S-E  
 Marine pollutant : No

**SECTION 15. REGULATORY INFORMATION**

OSHA Hazards : Combustible Liquid  
 Toxic by ingestion  
 Severe skin irritant  
 Moderate eye irritant  
 Possible Cancer Hazard

**CERCLA SECTION 103 and SARA SECTION 304 (RELEASE TO THE ENVIROMENT)**

The CERCLA definition of hazardous substances contains a "petroleum exclusion" clause which exempts crude oil. Fractions of crude oil, and products (both finished and intermediate) from the crude oil refining process and any indigenous components of such from the CERCLA Section 103 reporting requirements. However, other federal reporting requirements, including SARA Section 304, as well as the Clean Water Act may still apply.

TSCA Status : On TSCA Inventory  
 DSL Status : All components of this product are on the Canadian DSL list.  
 SARA 311/312 Hazards : Fire Hazard  
 Acute Health Hazard  
 Chronic Health Hazard

SARA III US. EPA Emergency Planning and Community Right-To-Know Act (EPCRA) SARA Title III Section 313 Toxic Chemicals (40 CFR 372.65) - Supplier Notification Required

**Components**

CAS-No.

<b>Naphthalene</b>	91-20-3
<b>Xylene</b>	1330-20-7
<b>1,2,4-trimethylbenzene</b>	95-63-6

PENN RTK US. Pennsylvania Worker and Community Right-to-Know Law (34 Pa. Code Chap. 301-323)

<u>Components</u>	<u>CAS-No.</u>
<b>Sulfur</b>	7704-34-9
<b>1,2,4-trimethylbenzene</b>	95-63-6
<b>Nonane</b>	111-84-2
<b>Xylene</b>	1330-20-7
<b>Naphthalene</b>	91-20-3
<b>Fuels, diesel, No 2; Gasoil - unspecified</b>	68476-34-6

MASS RTK US. Massachusetts Commonwealth's Right-to-Know Law (Appendix A to 105 Code of Massachusetts Regulations Section 670.000)

<u>Components</u>	<u>CAS-No.</u>
<b>Sulfur</b>	7704-34-9
<b>1,2,4-Trimethylbenzene</b>	95-63-6
<b>Nonane</b>	111-84-2
<b>Xylene</b>	1330-20-7
<b>Naphthalene</b>	91-20-3

NJ RTK US. New Jersey Worker and Community Right-to-Know Act (New Jersey Statute Annotated Section 34:5A-5)

<u>Components</u>	<u>CAS-No.</u>
<b>Sulfur</b>	7704-34-9
<b>1,2,4-Trimethylbenzene</b>	95-63-6
<b>Nonane</b>	111-84-2
<b>Xylene</b>	1330-20-7
<b>Naphthalene</b>	91-20-3
<b>Fuels, diesel, No 2; Gasoil - unspecified</b>	68476-34-6

California Prop. 65 : WARNING! This product contains a chemical known to the State of California to cause cancer.

Naphthalene 91-20-3

**SECTION 16. OTHER INFORMATION**

Further information

The information provided in this Safety Data Sheet is correct to the best of our knowledge, information and belief at the date of its publication. The information given is designed only as guidance for safe handling, use, processing,

storage, transportation, disposal and release and is not to be considered a warranty or quality specification. The information relates only to the specific material designated and may not be valid for such material used in combination with any other materials or in any process, unless specified in the text.

**Template** : GWU mbH  
**Prepared by** : Birlenbacher Str. 18  
D-57078 Siegen  
  
Germany  
  
Telephone: +49-(0)271-88072-0  
  
**Revision Date** : 01/27/2011

---

28, 34, 35, 37, 75, 90, 97, 108, 109, 1046, 1053, 1076, 1536, 1747, 1749, 1751, 1754, 1757, 1760, 1936

THIS PAGE INTENTIONALLY LEFT BLANK

**APPENDIX F - FRAME FOOT MARK SPREADSHEET**

THIS PAGE INTENTIONALLY LEFT BLANK



## APPENDIX F - FRAME FOOT MARK SPREADSHEET

The Frame Foot Mark Spreadsheet was developed as a location system for the Red Hill facility's Lower Access Tunnel. The spreadsheet uses the support frames located throughout the Lower Access Tunnel as location points. Each frame has been given a number, starting with frame number 1 and ending with frame number 690. The spreadsheet starts at tank 20 and ends at the entrance to the UGPH. Starting from tank 20 the distance to the entrance to the UGPH is 17,000 feet. The spreadsheet provides the frame number, feet from tank 20, delta from tank 20 (in feet), delta from the UGPH (in feet), feet from UGPH, and information and comments about items of interest located in the vicinity of the numbered frame (if applicable). Using this spreadsheet allows someone in the tunnel to know exactly how far they are from the UGPH or from Tank 20.

Table F.1: FRAME FOOT MARK SPREADSHEET					
Frame	Feet From Tank	Delta (From Tank) Feet	Delta (from UGPH) Feet	Feet From UGPH	Information and Comments
TK	0	0	0	17000	Tanks &
1	23	23	23	16977	Emergency Phone
2	40	17	17	16956	
3	63	23	23	16927	
4	84	21	21	16912	
5	106	22	22	16888	FDC
6	131	25	25	16864	163' Elevator #73 and Fire Control Panels, SCSR (15 Units)
7	153	22	22	16845	
8	178	25	25	16817	AFFF Zone #1, AFFF Mixing Closet
9	202	24	24	16796	
10	223	21	21	16774	Tanks
11	244	21	21	16750	, Emergency Phone
12	268	24	24	16726	
13	286	18	18	16711	298' Fire Evac. Zone 5L Sign, AFFF Sump, FOR Sump, Sump Pump Control
14	310	24	24	16681	299' Oil Tight Door
15	327	17	17	16670	335' Elevator #72
16	340	13	13	16650	Gauger Office, Emergency Phone
17	356	16	16	16630	
18	380	24	24	16609	Rest Room
19	403	23	23	16594	
20	424	21	21	16572	Tanks
21	443	19	19	16551	Train Battery Charger, Emergency Phone
22	465	22	22	16527	AFFF Zone #2, AFFF Mixing Closet
23	487	22	22	16508	
24	511	24	24	16484	
25	534	23	23	16463	FDC
26	556	22	22	16440	
27	581	25	25	16414	

Table F.1: FRAME FOOT MARK SPREADSHEET					
Frame	Feet From Tank	Delta (From Tank) Feet	Delta (from UGPH) Feet	Feet From UGPH	Information and Comments
28	604	23	23	16394	
29	625	21	21	16371	Tanks
30	643	18	18	16351	Emergency Phone
31	665	22	22	16326	120/208/480V Taps, AFFF Sump, Sump Pump Control
32	687	22	22	16308	Smoke Door (Between Frames 31 & 32)
33	712	25	25	16283	Camera
34	734	22	22	16264	FDC
35	757	23	23	16238	
36	781	24	24	16215	
37	804	23	23	16193	
38	826	22	22	16170	Tanks
39	842	16	16	16153	Fire Evac Zone 4L Sign, Emergency Phone
40	866	24	24	16123	120/208/480V Taps, AFFF Zone #3, AFFF Mixing Closet
41	887	21	21	16110	
42	912	25	25	16082	
43	935	23	23	16063	FDC
44	958	23	23	16038	
45	983	25	25	16013	
46	1005	22	22	15993	
47	1021	16	16	15974	
48	1026	5	5	15963	Tanks, Emergency Phone
49	1045	19	19	15933	
50	1067	22	22	15925	120/208/480V Taps, AFFF Sump, Sump Pump Control
51	1089	22	22	15906	Smoke Door #4 (Between Frames 50 & 51)
52	1113	24	24	15882	
53	1136	23	23	15861	FDC
54	1153	17	17	15843	
55	1182	29	29	15808	
56	1205	23	23	15797	
57	1228	23	23	15768	Tanks, Emergency Phone
58	1246	18	18	15750	AFFF Zone #4, AFFF Mixing Closet
59	1268	22	22	15723	120/208/480V Taps
60	1291	23	23	15704	
61	1312	21	21	15684	FDC
62	1335	23	23	15659	
63	1359	24	24	15637	
64	1384	25	25	15613	
65	1406	22	22	15592	

Table F.1: FRAME FOOT MARK SPREADSHEET					
Frame	Feet From Tank	Delta (From Tank) Feet	Delta (from UGPH) Feet	Feet From UGPH	Information and Comments
66	1428	22	22	15567	Tanks
67	1447	19	19	15548	Fire Evac Zone 4L Sign, Emergency Phone
68	1468	21	21	15524	120/208/480V Taps, AFFF Sump, Sump Pump Control
69	1492	24	24	15502	Smoke Door # 3 (Between Frames 68 & 69)
70	1513	21	21	15484	FDC, Camera
71	1538	25	25	15456	
72	1562	24	24	15436	
73	1583	21	21	15414	
74	1598	15	15	15396	
75	1610	12	12	15378	
76	1620	10	10	15365	
77	1629	9	9	15354	Tanks
78	1647	18	18	15335	Emergency Phone
79	1656	9	9	15335	120/208/480V Taps, AFFF Zone #5, AFFF Mixing Closet
80	1666	10	10	15316	
81	1678	12	12	15305	
82	1693	15	15	15292	
83	1708	15	15	15280	
84	1723	15	15	15265	FDC
85	1738	15	15	15250	
86	1753	15	15	15235	
87	1768	15	15	15220	
88	1783	15	15	15205	
89	1798	15	15	15190	
90	1810	12	12	15178	SCSR (15 Units)
91	1820	10	10	15165	
92	1830	10	10	15153	Tanks
93	1848	18	18	15135	Emergency Phone, Camera
94	1856	8	8	15135	480V Tap, AFFF Sump, Sump Pump Control
95	1866	10	10	15115	120/208V Taps
96	1884	18	18	15099	Smoke Door #2 (Between Frames 95 & 96)
97	1907	23	23	15084	Main Sump (Pumped to Tan 311), Fire Evac Zone 3 Sign
98	1927	20	20	15069	FDC
99	1944	17	17	15049	
100	1962	18	18	15028	Train Track Switch
101	1980	18	18	15011	1989 MOV-0154 (F-76)
102	1997	17	17	14994	

Table F.1: FRAME FOOT MARK SPREADSHEET					
Frame	Feet From Tank	Delta (From Tank) Feet	Delta (from UGPH) Feet	Feet From UGPH	Information and Comments
103	2003	6	6	14987	Block 4, Emergency Oil Pressure Door
104	2024	21	21	14955	Block 5
105	2049	25	25	14945	Survey Marker, Monitoring Well
106	2074	25	25	14924	2090' = 25+00
107	2112	38	38	14886	
108	2138	26	26	14873	
109	2163	25	25	14836	
110	2188	25	25	14810	
111	2213	25	25	14785	Emergency Phone
112	2238	25	25	14760	
113	2263	25	25	14735	
114	2288	25	25	14710	
115	2313	25	25	14685	480V Tap
116	2339	26	26	14659	
117	2362	23	23	14637	
118	2389	27	27	14607	
119	2414	25	25	14586	
120	2439	25	25	14559	
121	2464	25	25	14534	
122	2489	25	25	14509	2491' = 21+00
123	2514	25	25	14484	
124	2539	25	25	14459	
125	2564	25	25	14434	
126	2589	25	25	14409	
127	2614	25	25	14384	
128	2639	25	25	14359	
129	2665	26	26	14333	
130	2690	25	25	14309	2698' 120/208V Taps, 2707' 480V Tap
131	2715	25	25	14283	2723 = 18+ 69.72
132	2740	25	25	14258	2749 Survey Marker
133	2765	25	25	14233	
134	2790	25	25	14208	2792 = 18+00
135	2815	25	25	14183	2840 Concrete Bulkhead
136	2863	48	48	14135	1847' Block 37
137	2882	19	19	14139	1829' Block 38
138	2889	7	7	14103	2890 = 17+00, Start of "S-Curve"
139	2908	19	19	14072	
140	2923	15	15	14069	2935 Survey Marker
141	2940	17	17	14048	
142	2956	16	16	14034	

Table F.1: FRAME FOOT MARK SPREADSHEET					
Frame	Feet From Tank	Delta (From Tank) Feet	Delta (from UGPH) Feet	Feet From UGPH	Information and Comments
143	2974	18	18	14015	
144	2989	15	15	14002	2994' = 27+00, 2013 Concrete Bulkhead
145	3039	50	50	13949	
146	3064	25	25	13959	
147	3089	25	25	13909	3094 = 26+00
148	3114	25	25	13884	
149	3139	25	25	13859	
150	3164	25	25	13834	3176' Block 50
151	3189	25	25	13809	
152	3215	26	26	13783	3218 480V Tap
153	3239	24	24	13760	
154	3265	26	26	13732	
155	3290	25	25	13709	3295 = 24+00
156	3315	25	25	13683	
157	3340	25	25	13658	
158	3365	25	25	13633	
159	3390	25	25	13608	
160	3415	25	25	13583	
161	3440	25	25	13558	3451' Block 61, Survey Marker, Fire Evac Zone 3 Sign ( )
162	3465	25	25	13533	
163	3490	25	25	13508	3495' = 22+00
164	3515	25	25	13483	
165	3540	25	25	13458	
166	3565	25	25	13433	
167	3590	25	25	13408	3595' = 21+00
168	3615	25	25	13383	
169	3640	25	25	13358	Emergency Phone
170	3665	25	25	13333	
171	3690	25	25	13308	3695' = 20+00
172	3740	50	50	13258	
173	3766	26	26	13257	3722' 120/208V Taps, 3730' 480V Tap
174	3791	25	25	13208	
175	3816	25	25	13182	3829' Block 76
176	3841	25	25	13157	
177	3866	25	25	13132	
178	3891	25	25	13107	3896' = 18+00
179	3916	25	25	13082	
180	3941	25	25	13057	
181	3966	25	25	13032	3953' Survey Marker

Table F.1: FRAME FOOT MARK SPREADSHEET					
Frame	Feet From Tank	Delta (From Tank) Feet	Delta (from UGPH) Feet	Feet From UGPH	Information and Comments
182	3991	25	25	13007	3979' Block 82, Fire Evac Zone 3 Sign
183	4016	25	25	12982	3996' = 17+00
184	4041	25	25	12957	4053' Block 85, Survey Marker
185	4067	26	26	12931	
186	4092	25	25	12907	4096' = 16+00, 480V Tap
187	4117	25	25	12881	4130' Block 88
188	4142	25	25	12856	4154' Survey Marker
189	4167	25	25	12831	
190	4192	25	25	12806	
191	4217	25	25	12781	Fire Evac Zone 3 Sign
192	4242	25	25	12756	4254' Block 93, Survey Marker
193	4267	25	25	12731	
194	4292	25	25	12706	4297' 14+00, 4316' 120V Dplx, 4322' Emergency Phone
195	4341	49	49	12657	(2 Exhaust Fans)
196	4368	27	27	12654	
197	4393	25	25	12607	
198	4449	56	56	12549	Block 100, Upper Track Switch, Emergency Phone
199	4473	24	24	12556	Block 101, 120/208/480V Taps, Fire Evac Zone 3 Sign
200	4497	24	24	12500	Block 102, Emergency Phone
201	4521	24	24	12476	Block 103
202	4545	24	24	12452	Block 104
203	4566	21	21	12431	Block 105,
204	4583	17	17	12411	Block 106, 4597' Emergency Phone, d, Train Track Switch
205	4635	52	52	12355	4648' Back of NAVFAC Water Pumping Station
206	4659	24	24	12366	
207	4684	25	25	12313	4691' 120/208V Taps, 4708'
208	4710	26	26	12288	
209	4735	25	25	12264	Fire Evac Zone 2 Sign
210	4760	25	25	12238	
211	4785	25	25	12213	
212	4810	25	25	12188	
213	4836	26	26	12162	
214	4861	25	25	12138	
215	4885	24	24	12113	182' 120/208V Taps
216	4911	26	26	12086	
217	4936	25	25	12063	
218	4961	25	25	12037	260' Air Drop

Table F.1: FRAME FOOT MARK SPREADSHEET					
Frame	Feet From Tank	Delta (From Tank Feet)	Delta (from UGPH) Feet	Feet From UGPH	Information and Comments
219	4986	25	25	12012	
220	5011	25	25	11987	
221	5036	25	25	11962	
222	5061	25	25	11937	120/208V Taps
223	5086	25	25	11912	
224	5111	25	25	11887	
225	5136	25	25	11862	
226	5161	25	25	11837	
227	5186	25	25	11812	
228	5211	25	25	11787	
229	5236	25	25	11762	
230	5261	25	25	11737	568' Fire Evac Zone 2 Sign
231	5286	26	26	11711	593' 480/208V Taps, 588' LCP 12
232	5312	24	24	11688	
233	5336	26	26	11661	
234	5362	25	25	11636	
235	5387	25	25	11612	
236	5412	25	25	11586	
237	5437	25	25	11561	
238	5462	25	25	11536	113+00
239	5487	25	25	11511	
240	5512	25	25	11486	825' 120/208V Taps
241	5537	25	25	11461	
242	5562	25	25	11436	112+00
243	5587	25	25	11411	
244	5612	25	25	11386	
245	5637	27	27	11359	
246	5664	56	56	11305	
247	5720	25	25	11311	
248	5745	25	25	11284	
249	5770	24	24	11229	
250	5794	26	26	11202	
251	5820	26	26	11177	Fire Evac Zone 2 Sign, 120/208V Taps
252	5846	24	24	11155	
253	5870	25	25	11128	1180' Air Line Drop
254	5895	26	26	11101	
255	5921	25	25	11078	
256	5946	25	25	11053	1253 = 108+00
257	5971	23	23	11029	
258	5994	27	27	11000	

Table F.1: FRAME FOOT MARK SPREADSHEET					
Frame	Feet From Tank	Delta (From Tank) Feet	Delta (from UGPH) Feet	Feet From UGPH	Information and Comments
259	6021	25	25	10977	
260	6046	25	25	10954	1348' 120/208V Taps
261	6071	25	25	10927	1354' = 107+00
262	6096	25	25	10902	
263	6121	25	25	10877	
264	6146	25	25	10852	1455 = 106+00
265	6171	24	24	10828	
266	6195	26	26	10801	
267	6221	25	25	10777	
268	6246	25	25	10753	1561' 480/208V Taps
269	6271	24	24	10728	
270	6295	26	26	10701	1599' Fire Evac Zone 2 Sign Emergency Phone
271	6321	27	27	10675	
272	6348	25	25	10653	1656' = 104+00
273	6373	25	25	10626	
274	6396	23	23	10602	
275	6423	27	27	10573	
276	6448	25	25	10552	1755' Pipeline Vents
277	6473	25	25	10525	
278	6499	25	25	10500	
279	6524	25	25	10475	1826' 120/208V Taps
280	6549	25	25	10450	
281	6572	23	23	10427	
282	6596	24	24	10401	1895' Compressed Air Line Drop
283	6620	24	24	10378	
284	6645	25	25	10353	
285	6669	24	24	10330	101+00
286	6692	23	23	10306	
287	6716	25	25	10280	
288	6741	24	24	10258	
289	6781	39	39	10218	Bulkhead, Curve
290	6805	25	25	10208	2106' 120/208V Taps
291	6830	25	25	10169	Fire Evac Zone 2 Sign (Adit 3 - .54 mi.)
292	6856	25	25	10144	Air Line Ends
293	6881	25	25	10119	
294	6906	25	25	10094	
295	6931	25	25	10069	2235' = 98+00
296	6956	26	26	10043	Emergency Phone
297	6981	24	24	10020	
298	7006	25	25	9993	



Table F.1: FRAME FOOT MARK SPREADSHEET					
Frame	Feet From Tank	Delta (From Tank) Feet	Delta (from UGPH) Feet	Feet From UGPH	Information and Comments
299	7031	25	25	9969	
300	7056	25	25	9944	2357' 120/208V Taps, 97+00
301	7082	26	26	9918	
302	7106	25	25	9894	
303	7132	25	25	9868	
304	7157	25	25	9843	
305	7181	25	25	9818	
306	7207	25	25	9793	
307	7232	25	25	9768	
308	7257	25	25	9743	
309	7282	25	25	9718	2582 LCP 10, 480/208V Taps
310	7307	25	25	9693	Fire Evac Zone 2 Sign
311	7332	25	25	9668	
312	7358	25	25	9643	2658' = 94+00
313	7383	25	25	9618	
314	7408	25	25	9593	
315	7433	26	26	9567	
316	7458	24	24	9544	2758' = 93+00
317	7483	25	25	9517	
318	7508	26	26	9492	
319	7533	25	25	9468	2836' 120/208V Taps
320	7558	25	25	9442	2859' = 92+00
321	7583	25	25	9417	
322	7609	25	25	9392	
323	7634	25	25	9367	
324	7659	25	25	9342	
325	7684	25	25	9317	
326	7709	25	25	9292	
327	7733	25	25	9267	
328	7758	25	25	9242	NAVFAC Water Line Hot Tap (Weep)
329	7783	25	25	9217	
330	7808	25	25	9192	3110' 120/208V Taps
331	7833	26	26	9166	3116' Fire Evac Zone 2 Sign
332	7858	24	24	9143	
333	7883	25	25	9116	
334	7908	25	25	9092	
335	7933	26	26	9066	3259' = 88+00
336	7958	25	25	9042	Bulkhead
337	7984	25	25	9016	
338	8009	25	25	8991	

Table F.1: FRAME FOOT MARK SPREADSHEET					
Frame	Feet From Tank	Delta (From Tank) Feet	Delta (from UGPH) Feet	Feet From UGPH	Information and Comments
339	8035	25	25	8966	
340	8060	25	25	8941	3358' = 87+00, 120/208V Taps
341	8085	25	25	8916	
342	8110	25	25	8891	
343	8135	25	25	8866	
344	8160	25	25	8841	3458' = 86+00
345	8185	25	25	8816	
346	8210	25	25	8791	
347	8235	26	26	8765	
348	8260	25	25	8741	
349	8285	24	24	8716	3583' LCP9, 480/208V Taps
350	8310	26	26	8689	3593' Fire Evac Zone 3 Sign Emergency Phone
351	8335	24	24	8667	
352	8360	26	26	8639	
353	8385	25	25	8616	3678' Dent
354	8410	25	25	8590	
355	8436	26	26	8564	
356	8460	24	24	8541	3760' = 83+00
357	8485	25	25	8514	
358	8511	25	25	8490	
359	8537	25	25	8465	3839' 120/208V Taps
360	8562	25	25	8440	
361	8587	26	26	8414	
362	8612	25	25	8390	
363	8638	26	26	8363	
364	8662	24	24	8340	3962' = 81+00
365	8687	25	25	8313	
366	8712	25	25	8289	
367	8737	25	25	8264	
368	8762	25	25	8239	
369	8787	25	25	8214	4092' Fire Evac Zone 2 Sign
370	8812	25	25	8189	4117' 120/208V Taps, Uni-Strut on ground
371	8838	26	26	8163	
372	8863	25	25	8139	
373	8887	24	24	8114	
374	8913	26	26	8087	
375	8938	25	25	8064	Emergency Phone
376	8963	25	25	8038	4263' = 78+00
377	8988	25	25	8013	Bulkhead
378	9011	24	24	7989	

Table F.1: FRAME FOOT MARK SPREADSHEET					
Frame	Feet From Tank	Delta (From Tank) Feet	Delta (from UGPH) Feet	Feet From UGPH	Information and Comments
379	9037	26	26	7962	
380	9061	24	24	7940	4365' 120/208V Taps
381	9086	25	25	7913	
382	9111	25	25	7889	
383	9136	25	25	7864	
384	9161	25	25	7839	
385	9211	50	50	7789	
386	9238	27	27	7787	
387	9262	24	24	7740	Fire Evac Zone 2 Sign
388	9287	25	25	7712	
389	9312	25	25	7688	
390	9337	25	25	7663	
391	9362	25	25	7638	
392	9387	25	25	7613	
393	9412	25	25	7588	
394	9438	26	26	7562	
395	9462	24	24	7539	
396	9487	25	25	7512	
397	9512	25	25	7488	
398	9537	25	25	7463	
399	9562	25	25	7438	
400	9587	25	25	7413	
401	9612	25	25	7388	
402	9638	26	26	7362	
403	9662	24	24	7339	
404	9687	25	25	7312	
405	9712	25	25	7288	
406	9736	24	24	7264	
407	9761	25	25	7238	
408	9786	25	25	7214	
409	9811	25	25	7189	
410	9838	27	27	7162	
411	9862	24	24	7140	
412	9888	26	26	7111	
413	9913	25	25	7088	
414	9938	25	25	7062	
415	9963	25	25	7037	
416	9988	25	25	7012	
417	10013	25	25	6987	
418	10039	26	26	6961	

Table F.1: FRAME FOOT MARK SPREADSHEET					
Frame	Feet From Tank	Delta (From Tank Feet)	Delta (from UGPH) Feet	Feet From UGPH	Information and Comments
419	10063	24	24	6938	
420	10088	25	25	6911	
421	10113	25	25	6887	
422	10138	25	25	6862	
423	10163	25	25	6837	
424	10188	25	25	6812	
425	10213	25	25	6787	
426	10240	27	27	6760	
427	10264	24	24	6738	
428	10289	25	25	6710	Fire Evac Zone 2 Sign
429	10314	25	25	6686	Emergency Phone
430	10364	50	50	6636	
431	10389	25	25	6636	
432	10414	25	25	6586	
433	10440	26	26	6560	
434	10465	25	25	6536	
435	10490	25	25	6510	
436	10515	25	25	6485	
437	10540	25	25	6460	
438	10565	25	25	6435	
439	10590	25	25	6410	
440	10615	25	25	6385	
441	10641	26	26	6359	
442	10665	24	24	6336	
443	10690	25	25	6309	
444	10715	25	25	6285	
445	10740	25	25	6260	
446	10765	25	25	6235	Fire Evac Zone 2 Sign
447	10791	26	26	6209	
448	10817	26	26	6184	
449	10842	25	25	6159	
450	10867	25	25	6133	
451	10892	25	25	6108	
452	10917	25	25	6083	
453	10942	25	25	6058	
454	10967	25	25	6033	
455	10992	25	25	6008	
456	11017	25	25	5983	
457	11043	26	26	5957	
458	11067	24	24	5934	

Table F.1: FRAME FOOT MARK SPREADSHEET					
Frame	Feet From Tank	Delta (From Tank) Feet	Delta (from UGPH) Feet	Feet From UGPH	Information and Comments
459	11092	25	25	5907	
460	11117	25	25	5883	
461	11142	25	25	5858	
462	11167	25	25	5833	
463	11192	25	25	5808	
464	11217	25	25	5783	
465	11245	28	28	5755	
466	11268	23	23	5735	
467	11294	26	26	5704	
468	11319	25	25	5682	
469	11344	25	25	5656	
470	11369	25	25	5631	
471	11394	25	25	5606	
472	11419	25	25	5581	
473	11445	26	26	5555	
474	11471	26	26	5530	Fire Evac Zone 2 Sign
475	11495	24	24	5506	
476	11520	25	25	5479	
477	11545	25	25	5455	
478	11595	50	50	5405	
479	11620	25	25	5405	
480	11643	23	23	5357	
481	11670	27	27	5328	
482	11695	25	25	5307	
483	11720	25	25	5280	
484	11745	25	25	5255	
485	11770	25	25	5230	
486	11795	25	25	5205	
487	11820	25	25	5180	
488	11843	23	23	5157	
489	11870	27	27	5128	
490	11895	25	25	5107	
491	11921	26	26	5079	
492	11946	25	25	5055	
493	11971	25	25	5029	
494	11996	25	25	5004	
495	12021	25	25	4979	
496	12044	23	23	4956	
497	12071	27	27	4927	
498	12096	25	25	4906	

Table F.1: FRAME FOOT MARK SPREADSHEET					
Frame	Feet From Tank	Delta (From Tank Feet)	Delta (from UGPH) Feet	Feet From UGPH	Information and Comments
499	12121	25	25	4879	
500	12146	25	25	4854	
501	12171	25	25	4829	
502	12197	26	26	4803	
503	12221	24	24	4780	
504	12245	24	24	4754	
505	12272	27	27	4727	
506	12297	25	25	4705	
507	12323	26	26	4677	
508	12348	25	25	4653	
509	12373	25	25	4627	Emergency Phone
510	12398	25	25	4602	
511	12423	25	25	4577	
512	12447	24	24	4553	
513	12473	26	26	4526	
514	12498	25	25	4503	
515	12524	26	26	4476	
516	12549	25	25	4452	
517	12574	25	25	4426	
518	12599	25	25	4401	
519	12616	17	17	4384	
520	12662	46	46	4330	
521	12686	24	24	4335	
522	12708	22	22	4291	
523	12731	23	23	4266	
524	12752	21	21	4246	
525	12772	20	20	4224	
526	12794	22	22	4201	
527	12812	18	18	4185	
528	12838	26	26	4155	
529	12878	40	40	4123	
530	12903	25	25	4112	
531	12929	26	26	4071	
532	12953	24	24	4048	
533	12978	25	25	4021	Fire Evac Zone 2 Sign
534	13003	25	25	3997	
535	13026	23	23	3972	
536	13054	28	28	3949	
537	13079	25	25	3921	
538	13103	24	24	3896	

Table F.1: FRAME FOOT MARK SPREADSHEET					
Frame	Feet From Tank	Delta (From Tank Feet)	Delta (from UGPH) Feet	Feet From UGPH	Information and Comments
539	13126	23	23	3872	
540	13154	28	28	3849	
541	13179	25	25	3821	
542	13204	25	25	3796	
543	13227	23	23	3771	
544	13254	27	27	3748	
545	13279	25	25	3721	
546	13304	25	25	3696	
547	13329	25	25	3671	
548	13354	25	25	3646	
549	13379	25	25	3621	
550	13404	25	25	3596	
551	13427	23	23	3573	Evacuation Map
552	13454	27	27	3544	
553	13479	25	25	3523	Ribcage START
554	13504	25	25	3496	3518' = 35+00 EL 109.11
555	13529	25	25	3471	
556	13555	26	26	3445	3437' 120/208V Taps
557	13579	24	24	3421	██████████ Bulkhead, 3417' = 34+00
558	13638	59	59	3362	3363 NAVFAC ██████████ Into Overhead
559	13655	17	17	3345	3356' 6" 150# ██████████ Water
560	13680	25	25	3320	
561	13704	24	24	3296	3316' = 33+00 EL 108.85
562	13730	26	26	3270	
563	13755	25	25	3245	
564	13780	25	25	3220	
565	13805	25	25	3195	3216' = 32+00 EL 108.99
566	13828	23	23	3172	
567	13855	27	27	3145	3155' 120/208V Taps
568	13880	25	25	3120	
569	13905	25	25	3095	3116' = 31+00 EL 108.87
570	13930	25	25	3070	3085' Fire Evac Sign ██████████
571	13955	25	25	3045	
572	13981	26	26	3019	
573	14005	24	24	2995	3016' = 30+00 EL 108.42
574	14028	23	23	2972	
575	14056	28	28	2944	
576	14081	25	25	2919	2916' = 29+00 EL 107.65
577	14106	25	25	2894	2900' 120/208V Taps

Table F.1: FRAME FOOT MARK SPREADSHEET					
Frame	Feet From Tank	Delta (From Tank Feet)	Delta (from UGPH) Feet	Feet From UGPH	Information and Comments
578	14131	25	25	2869	
579	14156	25	25	2844	
580	14181	25	25	2819	
581	14206	25	25	2794	2815' = 28+00 EL 107.51
582	14230	24	24	2770	
583	14256	26	26	2744	
584	14280	24	24	2720	
585	14306	26	26	2694	2715' = 27+00 EL 107.43
586	14332	26	26	2668	2670' 480/208V Taps, LCP3
587	14357	25	25	2643	
588	14382	25	25	2618	
589	14407	25	25	2593	
590	14430	23	23	2570	Emergency Phone
591	14457	27	27	2543	2557' Fire Evac Sign
592	14494	37	37	2506	Bulkhead
593	14519	25	25	2481	
594	14544	25	25	2456	
595	14562	18	18	2438	
596	14581	19	19	2419	120/208V Taps
597	14607	26	26	2393	
598	14627	20	20	2373	
599	14647	20	20	2353	
600	14667	20	20	2333	
601	14685	18	18	2315	
602	14723	38	38	2277	Bulkhead, Tunnel Curve
603	14748	25	25	2252	
604	14773	25	25	2227	2214' = 22+00, EL 106.89
605	14797	24	24	2203	2205' 120/208V Taps
606	14824	27	27	2176	
607	14848	24	24	2152	
608	14873	25	25	2127	
609	14898	25	25	2102	2114' = 21+00 EL 106.77
610	14924	26	26	2076	
611	14949	25	25	2051	
612	14974	25	25	2026	
613	14998	24	24	2002	2013' = 20+00 EL. 106.72
614	15024	26	26	1976	
615	15049	25	25	1951	
616	15074	25	25	1926	1932 BDA7, 1937' 120/208V Taps
617	15099	25	25	1901	



Table F.1: FRAME FOOT MARK SPREADSHEET					
Frame	Feet From Tank	Delta (From Tank) Feet	Delta (from UGPH) Feet	Feet From UGPH	Information and Comments
618	15124	25	25	1876	
619	15149	25	25	1851	
620	15174	25	25	1826	
621	15198	24	24	1802	1813' = 18+00 EL. 106.56
622	15224	26	26	1776	
623	15249	25	25	1751	
624	15303	54	54	1697	██████████ Bulkhead, Tunnel Curve
625	15327	24	24	1673	1677' 480/208V Taps, LCP2
626	15352	25	25	1648	
627	15377	25	25	1623	
628	15403	26	26	1597	Fire Evac Zone 2 Sign ██████████ ██████████
629	15426	23	23	1574	
630	15450	24	24	1550	
631	15475	25	25	1525	
632	15498	23	23	1502	1512' = 15+00, EL 106.17
633	15524	26	26	1476	
634	15547	23	23	1453	
635	15573	26	26	1427	1412' = 14+00 Survey Mark, 120/208V Taps
636	15598	25	25	1402	
637	15622	24	24	1378	
638	15647	25	25	1353	
639	15671	24	24	1329	
640	15696	25	25	1304	
641	15719	23	23	1281	
642	15745	26	26	1255	
643	15769	24	24	1231	
644	15794	25	25	1206	1212' = 12+00 Survey Mark
645	15819	25	25	1181	
646	15845	26	26	1155	120/208V Taps
647	15868	23	23	1132	1120' Fire Evac Sign Zone 1 ██████████ ██████████
648	15893	25	25	1107	1111' = 11+00 Survey Mark
649	15917	24	24	1083	██████████ Concrete Bulkhead
650	15975	58	58	1025	1037' Track Switch
651	15986	11	11	1014	██████████ Emergency Phone
652	16016	30	30	984	██████████ Bulkhead
653	16041	25	25	959	972' Spare Breakers (4@)
654	16066	25	25	934	Fire Evac Zone 1 Sign
655	16091	25	25	909	9+00 Survey Mark
656	16116	25	25	884	

Table F.1: FRAME FOOT MARK SPREADSHEET					
Frame	Feet From Tank	Delta (From Tank Feet)	Delta (from UGPH) Feet	Feet From UGPH	Information and Comments
657	16141	25	25	859	
658	16166	25	25	834	
659	16192	26	26	808	
660	16216	24	24	784	8+00 Survey Mark
661	16241	25	25	759	
662	16266	25	25	734	
663	16292	26	26	708	7+00 Survey Mark
664	16317	25	25	683	679' 480/208V Taps, LCP1
665	16342	25	25	658	674' Fire Evac Zone 1 Sign
666	16367	25	25	633	
667	16392	25	25	608	6+00 Survey Mark
668	16417	25	25	583	
669	16442	25	25	558	
670	16467	25	25	533	520' 120/208V Taps
671	16492	25	25	508	Emergency Phone
672	16517	25	25	483	
673	16542	25	25	458	
674	16567	25	25	433	
675	16592	25	25	408	
676	16617	25	25	383	4+00 Survey mark
677	16642	25	25	358	
678	16667	25	25	333	
679	16692	25	25	308	3+00 Survey Mark
680	16717	25	25	283	
681	16764	47	47	236	Bulkhead
682	16780	16	16	220	233' Survey marker
683	16800	20	20	200	
684	16825	25	25	175	
685	16846	21	21	154	
686	16868	22	22	132	
687	16889	21	21	111	Fire Evac Zone 1 Sign
688	16910	21	21	90	Emergency Phone
689	16930	20	20	70	
690	16945	15	15	55	
691	17000	55	55	0	

**APPENDIX G - ACRONYMS**

THIS PAGE INTENTIONALLY LEFT BLANK

**APPENDIX G - ACRONYMS**

ACGIH	American Conference of Governmental Industrial Hygienists
ACP	Area Contingency Plan
AEC	Area Environmental Coordinator
AFFF	Aqueous Film Forming Foam
AFHE	Automated Fuel Handling Equipment
AOR	Area of Responsibility
API	American Petroleum Institute
AST	Aboveground Storage Tank
ATG	Automatic Tank Gauge
BBL	Barrels
BGS	Below Ground Surface
BOA	Basic Ordering Agreement
CADO	Civilian Assistant Duty Officer
CCTV	Closed Circuit Television
CDO	Command Duty Officer
CFM	Cubic Feet per Minute
CFR	Code of Federal Regulations
CNRH	Commander, Naval Region Hawaii
DDC	Direct Digital Control
DFM	Diesel Fuel - Marine Grade
DLA	Defense Logistics Agency
DOD	Department of Defense
DOH	Department of Health
DRMO	Defense Reutilization and Marketing Office
DRP	Disaster Response Plan
EAL	Environmental Action Level
EOC	Emergency Operation Center
EPA	U.S. Environmental Protection Agency
ERP	Emergency Response Plan
ERT	Environmental Response Team
ESSM	Emergency Ship Salvage Material
ETA	Estimated Time of Arrival
F-24	Jet A Aviation Fuel (NATO)
F-76	Diesel Fuel - Marine Grade
FACP	Fire Alarm Control Panel
FDC	Fire Department Connection
FFD	Federal Fire Department
FORFAC	Fuel Oil Reclamation Facility
FRT	Facility Response Team
FRP	Facility Response Plan
FYDP	Future Years Defense Plan
GAL	Gallon(s)
GPM	Gallons per Minute
GUI	Graphical User Interface

---

HAR	Hawaii Administrative Rules
HRR	Hawaiian Remediation and Recycling
HS	Hazardous Substance
HT	Harbor Tunnel
HW	Hazardous Waste
IAP	Incident Action Plan
IC	Incident Commander
ICP	Incident Command Post
ICP	Integrated Contingency Plan
ICS	Incident Command System
IDLH	Immediately Dangerous to Life and Health
IN	Inch
IR	Infrared
IWTC	Industrial Waste Treatment Center
JBPHH	Joint Base Pearl Harbor-Hickam
JP-5	Jet Fuel Propellant No. 5
LAT	Lower Access Tunnel
LEL	Lower Explosive Limit
LNAPL	Light Non-Aqueous Phase Liquid
MCL	Maximum Contaminant Level
MOV	Motor Operated Valve
MGD	Million Gallons per Day
MSHA	Mine Safety and Health Administration
MSL	Mean Sea Level
MTPMMS	Mass Technology Precision Mass Measurement System
NATO	North Atlantic Treaty Organization
NAVFAC	Naval Facilities Engineering Command
NAVSEA	Naval Sea Systems Command
NAVSUP FLCPH	Naval Supply Systems Command Fleet Logistics Center Pearl Harbor
NGA	Network Graphic Annunciators
NIMS	National Incident Management System
NOAA	National Oceanic and Atmospheric Administration
NOSC	Navy On-Scene Coordinator
NFPA	National Fire Protection Association
NRC	National Response Center
NRC	National Response Corporation
NSF	National Strike Force
NSFCC	National Strike Force Coordination Center
NWCF	Navy Working Capital Fund
NWS	Network Station
OHS	Oil and Hazardous Substance
OPA	Oil Pollution Act
OPD	Oil Pressure Door
OSHA	Occupational Safety and Health Administration
ORRT	Oceania Regional Response Team

---

OWOCRS	Open Water Oil Containment and Recovery System
PARS	Personnel Accountability Reporting System
PEL	Permissible Exposure Limit
PENCO	Pacific Environmental Company
PIAT	Public Information Assist Team
PIC	Person in Charge
PID	Photo-Ionization Detector
POL	Petroleum, Oil, and Lubricants
PPE	Personal Protective Equipment
PPM	Parts per Million
PSIG	Pounds per Square Inch Gauge
R.A.C.E	Rescue, Alert, Contain, Evacuate
RDC	Regional Dispatch Center
RHFSF	Red Hill Fuel Storage Facility
RIC	Rapid Intervention Crew
ROC	Regional Operations Center
RP	Red Plan
SCRC	Self-Contained Self-Rescue
SDS	Safety Data Sheets
SFO	Senior Fire Official
SMT	Spill Management Team
SOSC	State On-Scene Coordinator
SPCC	Spill Prevention, Control and Countermeasure
SSC	Scientific Support Coordinator
SSRBL	Site-Specific Risk-Based Levels
STEL	Short Term Exposure Limit
STT	Surge Tank Tunnel
SUPSALV	Supervisor of Salvage
SVM	Soil Vapor Monitoring
SVMP	Soil Vapor Monitoring Point
SWOB	Ship Waste Offload Barge
TLV	Threshold Limit Value
TPH	Total Petroleum Hydrocarbons
TSDF	Treatment, Storage and Disposal Facility
TWA	Time Weighted Average
TYCOM	Type Commander
UAT	Upper Access Tunnel
UC	Unified Command
UEL	Upper Explosive Limit
UFM	Unscheduled Fuel Movement
UGPH	Underground Pumphouse
USCG	United States Coast Guard
UST	Underground Storage Tank
UVIR	Ultra-Violet Infrared Detector
VOC	Volatile Organic Compounds
YON	Yard Oiler Navy

THIS PAGE INTENTIONALLY LEFT BLANK



**TAB A**  
**WORST-CASE DISCHARGE SCENARIO**

THIS PAGE INTENTIONALLY LEFT BLANK

## 1.0 WORST-CASE DISCHARGE SCENARIO

**Disclaimer: All spill volumes, release rates, release timelines, and fate and effect of the released product are purely hypothetical and have been developed for planning and training purposes only.**

### 1.1 Introduction

The worst-case discharge scenario involves the complete release of the contents of the largest bulk storage tanks at the RHFSF. Tank 14 is at capacity with 302,846 barrels (12,719,532 gallons) of JP-5. An earthquake of magnitude 8.0 hits Oahu and cuts power at the RHFSF. A section of 20" diameter piping between the outlet of Tank 14 and the skin valve cracks and fails, resulting in the uncontrolled emptying of the tank.

In this scenario, oil will flow down the LAT/HT towards the UGPH and Adit 2. If all the isolation doors in the tunnel were left open and failed to close due to the power outage, fuel would eventually fill the UGPH and escape Adit 1. Fuel would also escape Adit 2, following topographic and drainage features around the COMPACFLT Buildings (352 and 400), discharging into Halawa Stream via stormwater drains.

While it is extremely unlikely that a tank failure resulting in the loss of the entire storage capacity will occur, CNRH recognizes the need to develop these procedures for planning and training purposes.

Information on the worst-case discharge is provided in Table A.1.

TABLE A.1: WORST-CASE DISCHARGE INFORMATION	
Calculated WCD	302,846 bbls
Oil Group	Group 1 – Non-persistent
Operating Area	Nearshore / Inland

### 1.2 Actions to Prevent a Worst-Case Discharge

Actions to prevent or mitigate a worst-case discharge include:

- Close the OPD located just down the LAT, past Tanks 1 and 2. The door can be closed by pushing the manual push button on the bulkhead to the side of the door. The door will also automatically close when the high-level float in the OPD lift sump indicates that the sump is full. Closure of the door triggers the fire alarm system.
- Close the three isolation doors located in the LAT; Doors A, C, and the entrance to the UGPH. These doors are designed to stop a spill from migrating down the tunnel and will automatically close in the event of an oil spill.
- FLCPH Fuel Department maintain a heightened inspection and maintenance program for the Red Hill facility. All tanks are currently undergoing, or will undergo, a modified American Petroleum Institute (API) 653 inspection process. Tanks are pressure tested semi-annually, pipelines are regularly inspected and pressure tested.
- FLCPH Fuel Departments conduct regular Oil Pollution Act (OPA) 90 spill training and exercises.

**1.3 Fuel Escaping Adit 2**

Fuel escaping Adit 2 would pool in parking areas surrounding Building 352 and 400 and migrate through storm water drains into Halawa Stream. Figure A.1 provides a drainage map for the area and shows drainage flow direction, storm drain locations, and drainage outfalls into Halawa Stream.

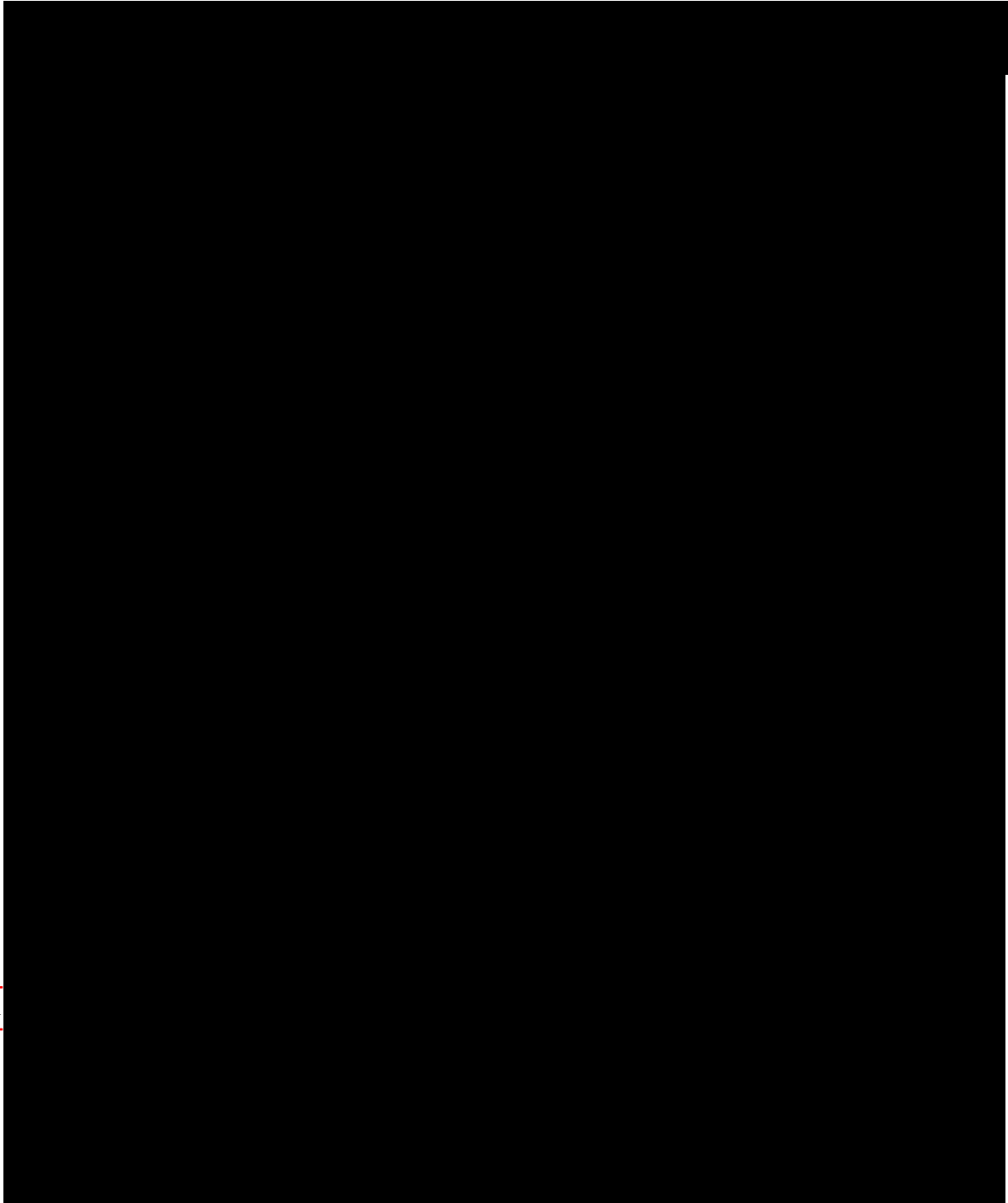

K

**Figure A.1: Drainage Map for Area around Adit 2**

## **1.4 Fuel Movement on Water**

Under normal Trade Wind (northwest) conditions fuel that makes its way into Halawa stream, and then Pearl Harbor, would be expected to move toward Ford Island and affect piers Hotel, Bravo, Mike and Sierra. Under Kona Wind (south) condition, winds would tend to move the fuel toward the shoreline of the USS Arizona Visitor Center, Aiea Bay, and Ford Island.

## **2.0 IMMEDIATE RESPONSE ACTIONS**

### **2.1 Fuel Department Personnel**

1. Immediately alert nearby personnel who may be exposed to the effects of the discharge.
2. Activate nearest fire alarm.
3. Evacuate the facility, tunnels, and adits (see Section 12).
4. Notify the Control Room Operator.
5. If properly trained, authorized, and it is safe to do so, initiate available on-site countermeasures (if applicable).

### **2.2 Control Room Operator**

1. Stop all fueling operations.
2. Activate emergency shutdown procedures if safe to do so (see Red Plan for procedures).
3. Close all motorized valves on pipelines.
4. Notify the Supervisory Distribution Facilities Specialist at 473-7824 or 216-1341 (cell) and Deputy Fuel Director at 473-7801 or 780-3703 (cell). If unable to reach Deputy Fuel Director, call the Fuel Director at 473-7833 or 690-0115 (cell).
5. Report spill immediately to Regional Dispatch Center at 911 or 471-7117.
6. Notify the COMPACFLT CDO at 471-3201 to initiate immediate evacuation of Buildings 250, 352 and 400.
7. Notify NAVSUP FLCPH CDO at 216-1339 (cell).
8. Account for the number of personnel (workers and contractors) evacuated.
9. Assess the situation, including:
  - Source and extent of release
  - Status of operation shutdown
  - Number of injured and their conditions
  - Probable direction of vapors
  - Estimate quantity of release
  - Direction of movement of release
  - Status of ignition sources
10. Follow all emergency standard operating procedures.
11. Refer to Red Plan at the beginning of this plan for additional action.
12. Document all actions.

### **2.3 Fuel Director/Emergency Coordinator**

1. Immediately notify:
  - Navy On-Scene Coordinator at 864-2463.
  - National Response Center at 800-424-8802 or 202-267-2675.
  - State Emergency Response Commission at 586-4249 or 247-2191 (after hours).

- Local Emergency Response Committee at 723-8958.
- 2. Submit Operation Report (OPREP-3) Navy Blue Message followed by an Oil or Hazardous Substance Spill/Release Message if directed by the NOSC or IC.
- 3. Refer to Red Plan at the beginning of this plan for additional action.

#### **2.4 Navy On-Scene Coordinator**

1. Ensure that all proper notifications were made (see Appendix A of the CNRH ICP).
2. Activate Navy SUPSALV to assist Port Operations FRT.
3. Recall CNRH SMT.
4. Establish command center and staging area.
5. Activate emergency response contractors if needed (see Appendix E of the CNRH ICP).

#### **2.5 Safety Officer**

1. Evaluate immediate public health and safety risks.
2. Recommend site control measures to isolate public from possible exposure (such as recommending evacuation or shelter in place).
3. Assess environmental conditions (such as air and water monitoring).
4. Conduct site safety evaluation and develop site safety plan.

### **3.0 INITIAL RESPONSE**

The Federal Fire Chief, or senior fire official, will assume the duties of the IC and take control of the spill during the emergency phase. The FFD will attempt to control the release, rescue the injured, monitor site safety, and guard against the possibility of fire. A major priority for the FFD will be to ensure the safety of the residents of both JBPHH and surrounding communities, and to the responders and other emergency personnel.

Due to the nature and volume of the spill, the areas surrounding Adit 1 and 2 at JBPHH and the USCG housing near the Red Hill facility may need to be evacuated due to the risks from vapor, fire, and explosions. The IC, in consultation with the NOSC and Safety Officer, will decide if additional evacuations will be needed for the base and surrounding communities.

- If facility personnel and base residents need to be evacuated, the IC will initiate the evacuation in accordance with the CNRH EMP.
- If communities' off-base need to be evacuated the IC will coordinate with the Hawaii Emergency Management Agency (HIEMA) 733-4300 and the Honolulu Fire Department 831-7771 in implementing community evacuation plans.

Concurrent with public safety evacuations, the FFD will conduct air monitoring at key areas, including the Red Hill facility, ventilation shafts, and adit entrances.

Once the initial emergency actions are implemented, the NOSC will assume direct control of the spill response and cleanup.

## 4.0 RESPONSE STRATEGIES

### 4.1 For Oil Escaping and Remaining in the Tunnel

Under this scenario, the HT and Adit 2 Spur Tunnel will be inundated with oil, with oil reaching the Adit 2 entrance in just 22-25 minutes after the release. Oil will quickly start to escape Adit 2, with approximately 10.5 million gallons escaping over the next few hours. Figure A.2 provides aerial photos of Adit 2. Response strategies and operations are discussed in the following paragraphs. (Note: other response strategies not discussed below may be used to respond to this scenario.)

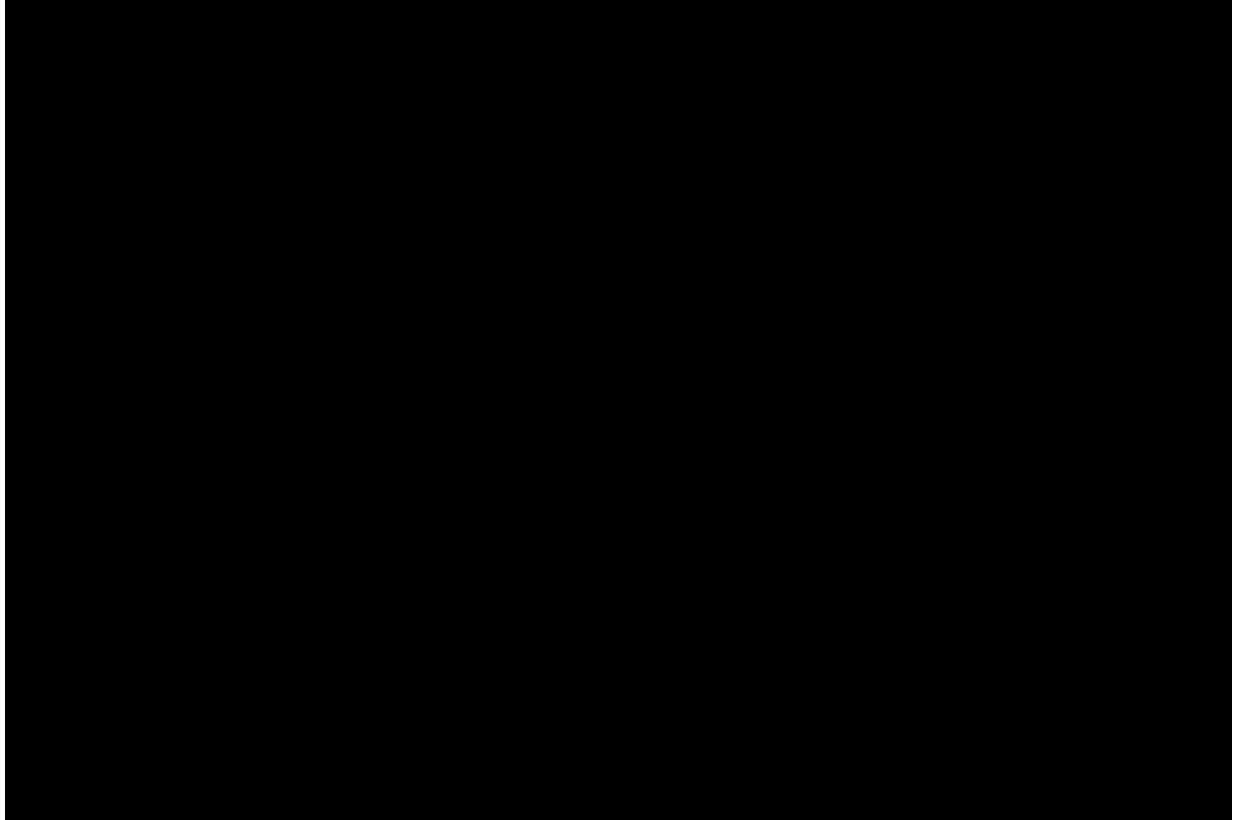

**Figure A.2: Aerial Photo Showing Location of Adit 2**

#### Containing Oil Escaping Adit 2

Adit 2 is located within a natural depression with steep embankments behind and to the sides of the adit (see Figure A.2). Directly in front of the adit are Buildings 352 and 400 which have large parking areas surrounding them. With less than one hour to respond, there will be little time to take countermeasures such as building an earthen berm. However, storm drain blockers should be considered for the parking areas to prevent oil from reaching Halawa Stream. Oil captured in the parking area could be pumped into tank trucks and transferred to empty storage tanks and/or a SWOB barge (see Section 10 for options). A key consideration while responding to this scenario will be the high accumulations of explosive vapors coming off the oil.

### Pumping Oil out of Adits 1 and 2, and Harbor Tunnel

Oil remaining in the tunnels, approximately 1.9 million gallons, will eventually have to be pumped out of the adits and tunnels. The HT sump pumps may be configured to pump oil through the isolation door that separates the HT from the UGPH (see Red Plan). The sump pumps are designed to send oily water (or oil in this case) to the Adit 1 sump which can then be sent to the swale or to Tanks B-1 and B-2 (378,000 gallons each) at the FORFAC facility. From these tanks, oil can be moved to various locations such as the UTF or to a SWOB or YON barge at Hotel Pier (see the Fuel Department's Operations and Maintenance Manual for details). Portable pumps could also be staged outside of Adit 1 to pump oil out of the adits and tunnels. See Section 10 for response equipment listings.

#### **4.2 For Oil that Directly Impacts the Water**

For oil that has already impacted Halawa Stream and Pearl Harbor, the strategy will be to contain and recover as much oil as possible near the source of its entry into Pearl Harbor. The overall strategy will be to prevent oil from spreading further into East Loch or the Entrance Channel, and to protect the sensitive shoreline and historical resources in and around the immediate spill location.

With oil impacting the water, the On Scene IC will immediately call the JBPHH Port Operations Control Tower at 474-6262. Port Operations will activate the FRT who will respond with boom, boats, skimmers, and vacuum trucks. Port Operations will also order the evacuation and closure of the Arizona Memorial and clear the area of all vessel traffic.

The FRT will attempt to contain and recover the oil in Halawa Stream before it escapes into Pearl Harbor by booming the entrance to the stream and using skimmers and vacuum trucks to recover oil. Section 4.3 details the containment and oil recovery booming strategy for a release into Halawa Stream.

#### **4.3 Containment and Oil Recovery Booming Strategy for Halawa Stream**

**Note:** This booming strategy is for guidance only. All booming strategies may need to be adjusted depending on the tides, current, wind, availability of equipment, and movement of oil.

##### **Booming Strategy:**

Contain and recover oil from Halawa Stream/Pearl Harbor and to protect environmentally sensitive areas.

##### **Site Conditions:**

- Near the mouth of Halawa Stream, the water is sufficiently deep for utility boats until approaching the shoreline.
- Booming site is tidal and may be affected by the prevailing Trade/Kona Winds.

##### **Initial Response Equipment:**

**Boom\*:** Approximately 800 feet of 24" harbor boom depending on water current and weather conditions. Mouth of stream will be double-boomed with two 400 foot lengths of boom.



**Vessels:** Two platform boats, four utility boats, and two skimmers

**Vacuum Tucks:** Seven vacuum tucks are available

- 2 @ FRT, 472-9942
- 3 @ NAVSUP FLCPH, 473-7801
- 2 @ NACFAC HI, 471-8481

**Personnel:** 2 to 3 crew per vessel; 1 to 2 personnel per vacuum truck

**Boom attachments:** Connect to fixed objects on both sides of the mouth of Halawa Stream

**Initial Response time:** < 1hour

\*Note: 42” boom available from SUPSALV’s ESSM facility located at Alpha Docks. Contact Navy SUPSALV at: 202-781-1731 Option #2 (Day) / 202-781-3889 (24hrs.) / 423-7055 (local)

**Oil Recovery:**

The mouth of the stream will be boomed with skimmers working within the boomed area recovering oil. Vacuum trucks will be staged on the shoreline adjacent to the stream mouth (Navy side) to recover oil using skimmers.

**Staging Areas:**

The staging area for vacuum trucks and other response equipment/supplies will be the parking lot near Mike 1 and 2 Piers (see Figure A.3). The staging area for the waterborne response will be the FRT Base on Ford Island (see Figure A.4). Staging areas may be moved depending on wind direction and vapor concentration.

**Booming Strategy Map:**

Figure A.5 shows an aerial photo depicting the booming strategy for Halawa Stream with the suggested oil recovery site. Figure A.6 shows the same information on a nautical chart.



**Figure A.3: Staging Area, Mike 1 and 2 Piers**



**Figure A.4: Staging Area at Facility Response Team Base, Ford Island**



### 4.4 Spill Trajectory

The National Oceanic and Atmospheric Administration (NOAA) oil spill trajectory model GNOME (General NOAA Operational Modeling Environment), can be used to develop spill trajectories. Contact a NOAA Scientific Support Coordinator for assistance at (206) 526-6081 or (206) 849-9926.

### 4.5 Oil Weathering

NOAA’s oil weathering model ADIOS (Automated Data Inquiry for Oil Spills) was used to establish the evaporation rate of a 10.5 million gallon release of F-76 into Halawa Stream under different wind speed conditions over time. The model assumes the fuel enters the water and spreads in an unhindered way. Data will vary depending on weather, currents and other factors at the time of the incident. Table A.2 shows evaporation rates for F-76 over time and Figure A.7 shows NOAA’s oil weathering model for the F-76 spill.

TABLE A.2: EVAPORATION RATES FOR F-76 OVER TIME						
Wind Speed	Percentage of Fuel Remaining <sup>1</sup>					
	24 Hours	48 Hours	72 Hours	96 Hours	120 Hours	
10 Knots	80%	45%	30%	20%	12%	1,300,000 Gallons Remain
15 Knots	55%	30%	15%	10%	03%	315,000 Gallons Remain
20 Knots	40%	12%	05%	157,500 Gallons Remain		

<sup>1</sup> Using ADIOS and extrapolating down to percentages less than 10%

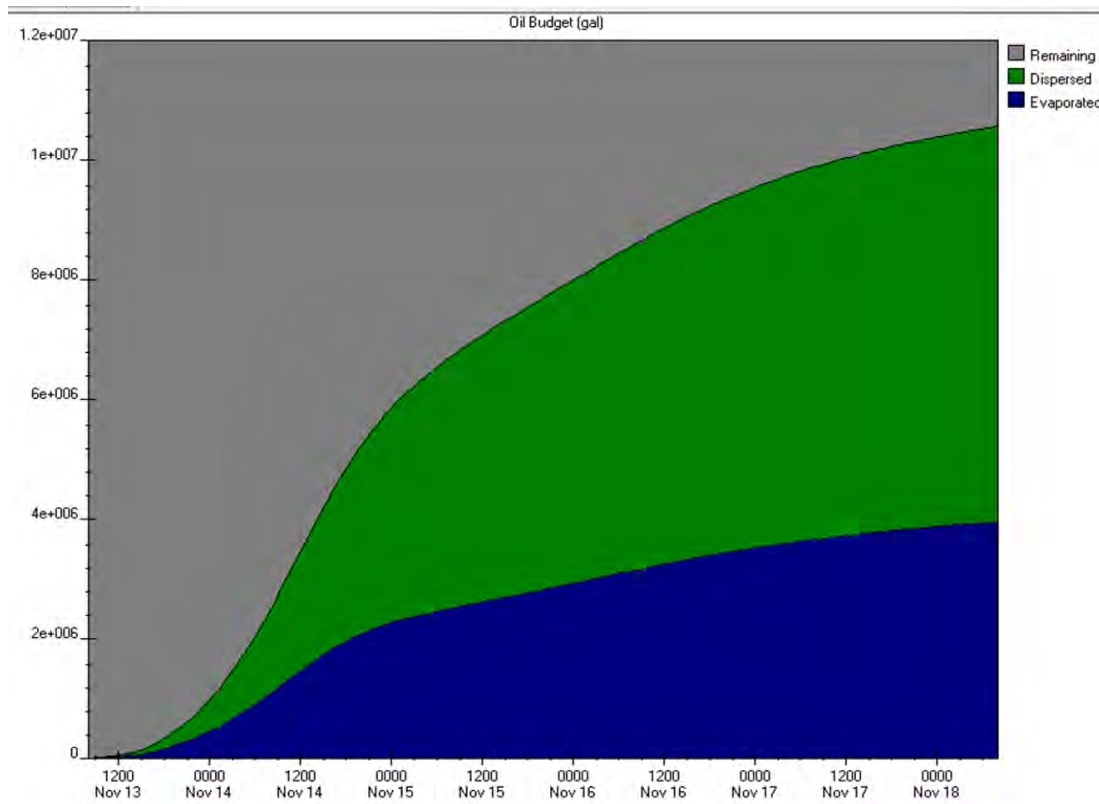

Figure A.7: NOAA Oil Weathering Model for F-76 Spill

**TAB B**  
**MAXIMUM MOST PROBABLE DISCHARGE SCENARIO**

THIS PAGE INTENTIONALLY LEFT BLANK

---

## 1.0 MAXIMUM MOST PROBABLE DISCHARGE SCENARIO

---

**Disclaimer: All spill volumes, release rates, release timelines, and fate and effect of the released product are purely hypothetical and have been developed for planning and training purposes only.**

---

### 1.1 Introduction

Contractors working in the Tank Gallery area of the LAT accidentally damage the 32" F-76 pipeline causing it to rupture. At the time of the accident, fuel transfer operations are being conducted. F-76 is being transferred from the Red Hill storage tanks to a vessel located at Hotel Pier. Within minutes the Control Room Operator notices a reduction in normal transfer pressure and immediately shuts down the pumping operation and closes the motorized block valves along the line. The total volume of fuel in the damaged section of pipeline is released (80,000 gallons) as the breach occurs just above the motorized block valve. Fuel starts to slowly travel down the LAT but is contained in the area by the newly constructed OPD just past Tanks 1 and 2.

## 2.0 IMMEDIATE RESPONSE ACTIONS

### 2.1 Fuel Department Personnel

1. Immediately alert nearby personnel who may be exposed to the effects of the discharge.
2. Activate nearest fire alarm.
3. Evacuate the facility, tunnels, and adits (see Section 12).
4. Notify the Control Room Operator.
5. If properly trained and authorized, and it is safe to do so, initiate available on-site countermeasures (if applicable).

### 2.2 Control Room Operator

1. Stop all fueling operations.
2. Activate emergency shutdown procedures if safe to do so (see Red Plan for procedures).
3. Close all motorized block valves on pipelines.
4. Notify the Supervisory Distribution Facilities Specialist at 473-7824 or 216-1341 (cell) and Deputy Fuel Director at 473-7801 or 780-3703 (cell). If unable to reach Deputy Fuel Director call the Fuel Director at 473-7833 or 690-0115 (cell).
5. Report spill immediately to Regional Dispatch Center at 911 or 471-7117.
6. Notify the COMPACFLT at 471-3201 for possible evacuation of Building 250.
7. Notify NAVSUP FLCPH CDO at 216-1339 (cell).
8. Account for the number of personnel (workers and contractors) evacuated.
9. Assess the situation, including:
  - Source and extent of release
  - Status of operation shutdown
  - Number of injured and their conditions
  - Probable direction of vapors
  - Estimate quantity and direction of movement of release
  - Status of ignition sources
10. Follow all emergency standard operating procedures.
11. Refer to Red Plan at the beginning of this plan for additional action.
12. Document all actions.

### 2.3 Fuel Director/Emergency Coordinator

1. Immediately notify:
  - Navy On-Scene Coordinator at 864-2463.
  - National Response Center at 800-424-8802 or 202-267-2675.
  - State Emergency Response Commission at 586-4249 or 247-2191 (after hours).
  - Local Emergency Response Committee at 723-8958.
2. Submit OPREP-3 Navy Blue Message followed by an Oil or Hazardous Substance Spill/Release Message if directed by the NOSC or IC.
3. Refer to Red Plan at the beginning of this plan for additional action.

### 2.4 Navy On-Scene Coordinator

1. Ensure that all proper notifications were made (see Appendix A of the CNRH ICP).
2. Recall CNRH SMT.
3. Establish command center and staging area.
4. Activate emergency response contractors; if applicable (see Appendix E of the CNRH ICP).

### 2.5 Safety Officer

1. Evaluate immediate public health and safety risks.
2. Recommend site control measures to isolate public from possible exposure (such as recommending evacuation or shelter in place).
3. Assess environmental conditions (such as air and water monitoring).
4. Conduct site safety evaluation and develop site safety plan.

## 3.0 INITIAL RESPONSE

The Federal Fire Chief, or senior fire official, will assume the duties of the IC and take control of the spill during the emergency phase. The FFD will attempt to control the release, rescue the injured, monitor site safety, and guard against the possibility of fire. A major priority for the FFD will be to ensure the safety of the residents in the surrounding area, and to the responders and other emergency personnel.

Due to the nature and volume of the spill, the areas surrounding Adit 1 and 2 at JBPHH and the USCG housing near the Red Hill facility may need to be evacuated due to the risks from vapor, fire, and explosions. The IC, in consultation with the NOSC and Safety Officer, will decide if additional evacuations will be needed for the base and surrounding communities.

- If facility personnel and base residents need to be evacuated, the IC will initiate the evacuation in accordance with the CNRH EMP.
- If communities off-base need to be evacuated the IC will coordinate with the HIEMA 733-4300 and the Honolulu Fire Department 831-7771 in implementing community evacuation plans.

Concurrent with public safety evacuations, the FFD will conduct air monitoring at key areas, including the Red Hill facility, ventilation shafts, and adit entrances. Once the initial emergency actions are implemented, the NOSC will assume direct control of the spill response and cleanup.



#### 4.0 RESPONSE STRATEGIES

Pumps staged outside the isolation door below Tanks 1 and 2 can be used to pump any free fuel out of the LAT where the spill occurred. Hoses can be run from the pumps to temporary storage located outside of Adit 3. Sump pumps within the spill area may also be used to pump free fuel from the tunnel (see the Fuel Department's Operation and Maintenance Manual for details).

Depending on wind and incident conditions, staging areas for a response to this scenario will be outside of Adit 3 (see Figure B.1). See Section 10 for a listing of response equipment available to the NOSC for responding to the spill in this scenario.

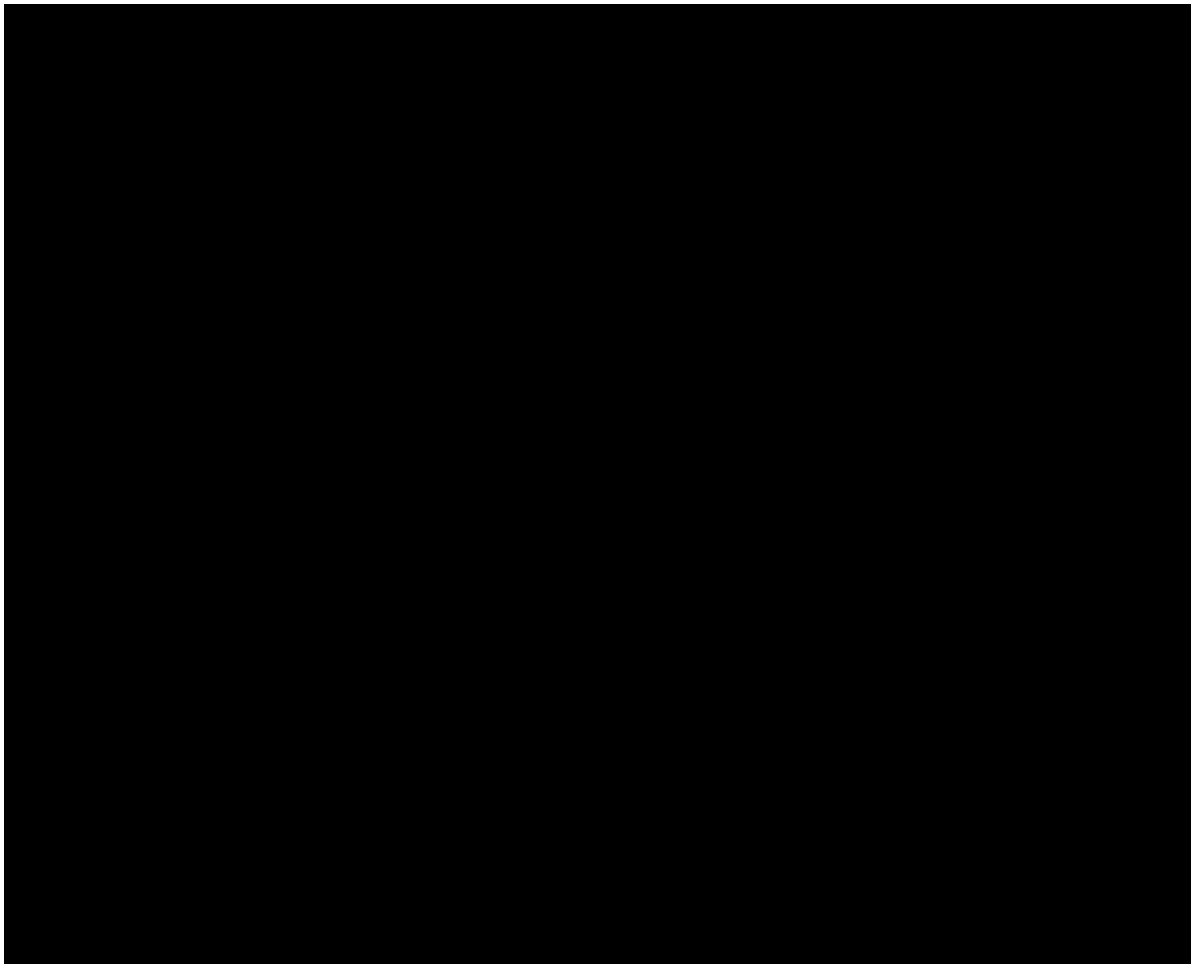

**Figure B.1: Aerial Photo Showing Staging Area Outside of Adit 3**

THIS PAGE INTENTIONALLY LEFT BLANK

## Appendix C: Tank Drain-Down Plans at Hypothetical Release Rates

This appendix describes the release response and tank drain-down plans under three different scenarios.

### **Tank Drain-Down Scenario I: (Two Tankers Readily Available to Deploy to Pearl Harbor)**

Assumptions:

- The largest of the Red Hill Tanks, which is used for this scenario, contains 12.6 million gallons.
- No available ullage at Hickam or Pearl Harbor upon confirmed release discovery.
- The hypothetical release amounts to 10 gallons per hour (gph).
- Two tankers could be needed to hold all the fuel.
- Two tankers are readily available, able to deploy to Pearl Harbor and moor at Hotel Pier.
- Up to 7 to 10 days are required for tanker deployment (approximately 2,400 gallons would be lost during that time).

Assuming there was a confirmed release at one of the Red Hill tanks, the Control Room Operator will immediately transfer fuel at maximum capacity to any other tank (with the same fuel specification) available with ullage (available tank space). The existing plant configuration and the amount of inventory of JP-5, F-24, and F-76 in the bulk fuel storage tanks determine the amount of working ullage. Other dependent factors are time of year and operational conditions due to change of operational tempo, which is an increase or decrease in the amount of fuel issued or the amount of fuel sold to customers. When there is an increase in fuel sales, that decreases the amount of inventory located in a fuel tank, depending on product, and increases the ullage available before the fuel facility is resupplied with fuel stock. Simultaneously, the Terminal Manager will contact Defense Logistics Agency (DLA) Energy Pacific to request one or two tankers to be immediately deployed to remove the remaining fuel from the tank. The transportation contracts that DLA Energy manages for fuel delivery and receipt can be used to deploy tankers to a location in an emergency. The approximate time for deployment is dependent on the timing of the release and can range from 7 to 10 days. Once the tankers arrive and moor to Hotel Pier, at Pearl Harbor, it would take approximately 36 hours to empty a Red Hill Tank of 12.6 million gallons, based on the gravity flow rate of jet fuel. Jet fuel can be issued or gravity-fed at approximately 348,000 gph. If diesel were the product in question, it would take 23 hours to remove the fuel. Diesel fuel can be issued or gravity-fed at approximately 546,000 gph.

Therefore, the most extreme scenario for removal of fuel from a Red Hill tank using two tankers would be 2,760 gallons of fuel (2,400 gallons while waiting for tanker deployment and 360 gallons while loading the tanker). This quantity of gallons released would be significantly decreased if one tanker were available to deploy faster and if the tank held less than 12.6 million gallons, as is the case under normal operations. Also, if available ullage in the Joint Base Pearl Harbor complex was available, the tank would be drained within a shorter timeframe.

## **Tank Drain-Down Scenario II: (Near-Empty Upper Tank Farm available)**

### **Assumptions:**

- Release rate of 0.499 gph.
- The tank is at the high operating limit of 212 feet and is holding 269,000 barrels (bbl) of fuel (normal operating conditions)
- The tank is a JP-5 tank (most likely scenario).
- Tank is idle (no fuel in or out) (most likely scenario).
- Release is at dead bottom center of tank bottom of tank (unlikely scenario).
- As tank empties, the release rate remains constant at 0.499 gph regardless of decreased head pressure (conservative assumption).
- Flow rate of fuel to Upper Tank Farm's Tank 55 will average 5,000 bbl per hour.
- Flow rate from Tank 55 to Red Hill tank will be 5,000 bbl per hour.

### **Unscheduled Fuel Movement (UFM) Alarm Parameters:**

- 1/16 inch UFM sensitivity equates to up to 306 gallons.
- UFM "Warning" alarm will sound at ½ inch = 2,448 gallons
- UFM "Critical" alarm will sound at ¾ inch = 3,672 gallons

### **Detection:**

At a release rate of 0.499 gph, the UFM "Warning" alarm would require 4,896 hours or 204 days to alert (2,443 gallons), and the UFM "Critical" alarm would require an additional 2,448 hours or 102 days to alert (an additional 1,221 gallons). This involves a highly conservative assumption that none of the other release detection systems triggered a response.

- Time +0.0 hours: Operator will align fuel from the affected tank to Tank 55, which has 7 feet of fuel in the tank.
- Time +22.4 hours: Operator will finish filling Tank 55, which will remove 112,000 bbl from affected Red Hill tank (157,000 bbl remain in affected tank).
- Time +44.8 hours: Operator will pump up 112,000 bbl of fuel from Tank 55 to near-empty Red Hill tank.
- Time +45.05 hours: Operator will align fuel from the affected tank to Tank 55, which has 7 feet of fuel in the tank.
- Time +67.45 hours: Operator will finish filling Tank 55, which will remove 112,000 bbl from affected Red Hill tank (45,000 bbl remain in affected tank).
- Time +77.45 hours: Operator will pump up 50,000 bbl of fuel from Tank 55 to near-empty Red Hill tank.
- Time +77.7 hours: Operator will align fuel from the affected tank to Tank 55, which has sufficient ullage to take the affected tank to low suction.
- Time +86.3 hours: Operator will finish filling Tank 55, which will remove 43,000 bbl from affected Red Hill tank (1,500 bbl remain in affected tank).
- Time +86.3 hours: Fuel workers will remove the remaining fuel (1,500 bbl) from the tank bottom drain valve to the main pipeline via temporary hose.

- Time +96.3 hours: Remaining 1,500 bbl will finished being removed from tank.
- Time +96.3 hours: COMPLETE: Tank is empty (will show near zero on the Automated Fuel Handling Equipment [AFHE]) with only residuals and sludge remaining.

Fuel released during drain down: approximately 48 gallons lost from determination to empty.

### **Tank Drain-Down Scenario III: (No Upper Tank Farm Available)**

#### **Assumptions:**

- Release rate of 0.499 gph.
- The tank is at the high operating limit of 212 feet and is holding 269,000 bbl of fuel (normal operating conditions)
- The tank is a JP-5 tank (most likely scenario).
- Tank is idle (no fuel in or out) (most likely scenario).
- Release is at dead bottom center of tank bottom of tank (unlikely scenario).
- As tank empties, the release rate remains constant at 0.499 gph regardless of decreased head pressure (conservative assumption).

#### **UFM Alarm Parameters:**

- 1/16 inch UFM sensitivity equates to up to 306 gallons.
- UFM "Warning" alarm will sound at 1/2 inch = 2,448 gallons
- UFM "Critical" alarm will sound at 3/4 inch = 3,672 gallons

#### **Detection:**

At a release rate of 0.499 gph, the UFM "Warning" alarm would require 4,896 hours or 204 days to alert (2,443 gallons), and the UFM "Critical" alarm would require an additional 2,448 hours or 102 days to alert (an additional 1,221 gallons). This involves a highly conservative assumption that none of the other release detection systems triggered a response.

- Time +0.0 hours: Pump up Tank 55 to tanks with available ullage until 112,000 bbl ullage is available in Tank 55.
- Time +22.3 hours: Operator will align fuel from the affected tank to Tank 55, which has 7 feet of fuel in the tank.
- Time +44.7 hours: Operator will finish filling Tank 55, which will remove 112,000 bbl from affected Red Hill tank (157,000 bbl remain in affected tank).
- Time +66.9 hours: Operator will pump up 112,000 bbl of fuel from Tank 55 to near-empty Red Hill tank.
- Time +67.1 hours: Operator will align fuel from the affected tank to Tank 55, which has 7 feet of fuel in the tank.
- Time +67.45 hours: Operator will finish filling Tank 55, which will remove 112,000 bbl from affected Red Hill tank (45,000 bbl remain in affected tank).

- Time +77.45 hours: Operator will pump up 50,000 bbl of fuel from Tank 55 to near-empty Red Hill tank.
- Time + hours: Operator will align fuel from the affected tank to Tank 55, which has sufficient ullage to take the affected tank to low suction.
- Time +108.6 hours: Operator will finish filling Tank 55, which will remove 43,000 bbl from affected Red Hill tank (1,500 bbl remain in affected tank).
- Time +108.9 hours: Fuel workers will remove the remaining fuel (1,500 bbl) from the tank bottom drain valve to the main pipeline via temporary hose.
- Time +118.6 hours: Remaining 1,500 bbl will be finished being removed from tank.
- Time +118.6 hours: COMPLETE: Tank is empty (will show near zero on AFHE) with only residuals and sludge remaining.

Fuel released during drain down: approximately 59 gallons lost from determination to empty

Note that under this scenario, it could take a little longer than 118.6 hours if it is necessary to switch between multiple tanks; however, this would add only 2 to 4 hours, so total fuel lost is not likely to exceed approximately 61 gallons.

## Appendix D: Bounding Estimates of Hypothetical Release Volumes

As discussed in the Response to RFI 11, four hypothetical scenarios were developed (based on discussions with the Red Hill Administrative Order on Consent [AOC] Regulatory Agencies) to calculate bounding estimates of potential release volumes:

- Scenario #1: Minor Release (0.04 gallons per hour [gph] flow rate)
- Scenario #2: Small Release (0.08-inch hole or 1.5 gallons per minute [gpm])
- Scenario #3: Medium Release (0.5-inch hole or 72 gpm)
- Scenario #4: Large Release (e.g., resulting from nozzle failure)

This appendix presents the assumptions used in the development of these release scenarios and the resultant evaluations. These estimates help formulate and describe the Red Hill Facility operator responses and strategies to combat a hypothetical future release from the Facility.

### **Scenario #1: A Minor Release in a Red Hill Tank (0.04 gph)**

Scenario #1 involves a hypothetical minor release that goes undetected for an entire year. A tank with a minor release rate of 0.04 gph could lose up to approximately 351 gallons per year into the environment. The calculations in this scenario use the conservative assumption that the tank is filled to the high level of 212 feet, which above normal operating levels. An assumption that the minor release is located at the bottom of the tank is also made. At this rate, approximately 0.96 gallon is lost per day into the environment. While the risk and loss are relatively small, if the minor release is in a static tank that has not seen fuel movement at all, the fuel release would be detected when there is a change of 1/16 inch in the tank, i.e., at day 318 (based on the conservative assumption that other existing or planned release detection systems did not detect the release sooner). If the minor release is in a tank that is consistently on issue or has fuel receipts, then the minor release may go undetected longer. Once the release is detected by noticing the change in fuel level, by either the Control Room Operator or the Responsible Officer, the operator will manually gauge the tank and review data from other release detection systems to verify and confirm a release.

The amount of fuel released is then a function of many variables including the release flow rate, the initial fuel level, the height of the hole above the tank bottom, the time at which fuel is then being moved from the tank, the rate the tank is emptied, and delays experienced during the response.

Five transfer (“XFR”) approaches may be involved in the strategy to empty a tank:

- XFR1 – Inter-Tank Transfer by Gravity
- XFR2 – Move Fuel to Upper Tank Farm by Gravity
- XFR3 – Cyclically Move Fuel to Another Tank Using the Cargo Pumps and Surge Tanks or via the Upper Tank Farm
- XFR4 – Move Fuel by Gravity to Alternate Tanks or Ships at Pearl Harbor

- XFR5 – Drain the Last 7.5 feet of Fuel from the Lower Dome Using the Fuel Lines to the Underground Pump House

Under this scenario, the following response would occur:

- Time +0.0 hours: Operator will align fuel from the affected tank to Upper Tank Farm Tank 55, which has 7 feet of fuel in the tank.
- Time +22.4 hours: Operator will finish filling Tank 55 which will remove 112,000 barrels (bbl) from affected Red Hill tank (157,000 bbl remain in affected tank).
- Time +44.8 hours: Operator will pump up 112,000 bbl of fuel from Tank 55 to near-empty Red Hill tank.
- Time +45.05 hours: Operator will align fuel from the affected tank to Tank 55, which has 7 feet of fuel in the tank.
- Time +67.45 hours: Operator will finish filling Tank 55, which will remove 112,000 bbl from affected Red Hill tank (45,000 bbl remain in affected tank).
- Time +77.45 hours: Operator will pump up 50,000 bbl of fuel from Tank 55 to near-empty Red Hill tank.
- Time +77.7 hours: Operator will align fuel from the affected tank to Tank 55, which has sufficient ullage to take the affected tank to low suction.
- Time +86.3 hours: Operator will finish filling Tank 55 which will remove 43,000 bbl from affected Red Hill tank (1,500 bbl remain in affected tank).
- Time +86.3 hours: Fuel workers will remove the remaining fuel (1,500 bbl) from the tank bottom drain valve to the main pipeline via temporary hose.
- Time +96.3 hours: Remaining 1,500 bbl will be removed from the affected tank.
- Time +96.3 hours: COMPLETE: Tank is empty (will show near zero on Automated Fuel Handling Equipment [AFHE]) with only residuals and sludge remaining.

In this scenario, once the release is identified and confirmed, the total amount of fuel lost from day 1 of the release until the tank is drained is up to approximately 310 gallons of fuel.

### **Scenario #2: Small Fuel Release (0.08-inch hole or 1.5 gpm)**

This scenario involves a hypothetical small release at 1.5 gpm through the tank liner while the tank is idle; i.e., with its skin and ball valves closed. This flow rate would be sufficient to drop the tank level by 1/2 inch in about 27 hours, which would trigger the AFHE system's automatic low-level warning alarm. A second low level critical alarm would sound if the level change were greater than 3/4 inch; i.e., approximately 41 hours after development of the hypothetical 1.5 gpm release. Conservatively assuming the affected tank is filled to 212 feet and the hole is at the bottom of the tank, this flow rate corresponds to a flow area of 0.08 inch in equivalent diameter. Response to RFI 11 Table 1 shows the time in hours to drain the fuel level from a tank starting from 212 feet to 50 feet through a postulated hole at the piping outlet into the lower access tunnel (i.e., a loss of about 226,000 bbl), as a function of hole size. In this highly unlikely (almost impossible) event,



if no actions are taken when the 0.08-inch-diameter hole is discovered via the AFHE system, it will take 116,546 hours for fuel to be drained from the 212-foot level to the 50-foot level at a flow rate of 1.8 gpm. However, given the existing and proposed release detection systems, there would be abundant time to mitigate the release before this occurred. It will take approximately 3.3 hours to drop the fuel level by 1/16 inch, which would be noticed and acted upon by the Control Room Operator. Another operator would be sent to manually gauge the tank and check the other release detection systems to verify and confirm whether a release has occurred. At 1.8 gpm, the operator has sufficient time to start tank drain-down procedures.

The tank drain-down procedure for this scenario commences once the release is verified and confirmed by the manual gauger. Under this scenario, the following response would occur:

- Time +0.0 hours: Operator will align fuel from the affected tank to Upper Tank Farm's Tank 55, which has 7 feet of fuel in the tank.
- Time +22.4 hours: Operator will finish filling Tank 55, which will remove 112,000 bbl from affected Red Hill tank (157,000 bbl remain in affected tank).
- Time +44.8 hours: Operator will pump up 112,000 bbl of fuel from Tank 55 to near-empty Red Hill tank.
- Time +45.05 hours: Operator will align fuel from the affected tank to Tank 55, which has 7 feet of fuel in the tank.
- Time +67.45 hours: Operator will finish filling Tank 55, which will remove 112,000 bbl from affected Red Hill tank (45,000 bbl remain in affected tank).
- Time +77.45 hours: Operator will pump up 50,000 bbl of fuel from Tank 55 to near-empty Red Hill tank
- Time +77.7 hours: Operator will align fuel from the affected tank to Tank 55, which has sufficient ullage to take the affected tank to low suction.
- Time +86.3 hours: Operator will finish filling Tank 55, which will remove 43,000 bbl from affected Red Hill tank (1,500 bbl remain in affected tank).
- Time +86.3 hours: Fuel workers will remove the remaining fuel (1,500 bbl) from the tank bottom drain valve to the main pipeline via temporary hose.
- Time +96.3 hours: Remaining 1,500 bbl will be removed from tank.
- Time +96.3 hours: COMPLETE: Tank is empty (will show near-zero on AFHE) with only residuals and sludge remaining.

In this scenario, once the release is identified and confirmed, the total amount of fuel lost from day 1 of the release until the tank is drained could be up to approximately 10,368 gallons.

### **Scenario #3: Medium Fuel Release (0.5-Inch Hole or 72 gpm)**

This scenario (highly unlikely due to the automated fuel shutoff from a high-high-level alarm) is included here as a conservative evaluation. This scenario considers a medium-size hole of 0.5 inch in equivalent diameter, and assumes the hole is located above the high level of 212 feet. It is assumed a fuel receipt is in motion and continues into a tank overfill condition that requires immediate action. It is considered highly likely that any liner through holes corresponding to a

release flow rate greater than 1.5 gpm would be detected fairly quickly and before the hole has a chance to grow much larger. However, it is conceivable that a 0.5-inch through hole could possibly develop high in the upper dome of a tank, well above the nominal operating fuel levels. Fuel release could potentially occur if the fill level were exceeded. Inter-tank transfer by gravity is assumed not to be used as the method to transfer fuel from the source tank for these events because of the high fuel level involved and the geometry of the Facility tanks (typically, the initial fuel level in the receiving tank would be much less than this, and the amount of overfilling would be limited). Release flow rates through the hypothetical hole would be a function of the extent of overfilling. Based on Red Hill Facility fuel movement data from early 2017, an average filling rate of 2,080 bbl or 85,280 gph is assumed. Typically, this filling rate would be decreased as the fuel evolution is about to end. An assumed fill rate of 2,080 bbl or 85,280 gallons per hour is much larger than the release flow, for any amount of overfill. Therefore, the release might not be detected until the fuel movement to fill the tank is eventually stopped.

The cargo pumps are assumed being used to transfer fuel from tank sources below the underground pump house (e.g., the Upper Tank Farm) to the receiving tank. It is unlikely that such an overfilling would occur because there is careful planning before each fuel evolution is begun, and there are limits on the amount of fuel available at the source tank. In addition to the Control Room crew, staff are positioned at the source tank to ensure that no more than the planned amount of fuel is transferred. A carefully defined high operating limit for each tank is set by adherence to American Petroleum Institute (API) 653 criteria. For most tanks (i.e., Tanks 5 through 20), this high operating limit is set at approximately 10 feet above the annual release tightness level (e.g., 221.78 feet for Tank 15), although its height is not based on that test level.

For the shorter tanks (Tanks 2 through 4), the high operating limit is set about 2 feet above the annual release tightness test level. A high-high level alarm probe is then set 2 inches higher than the high operating limit; i.e., at 221.94 feet for Tank 15). If level increases above the high-high level, an alarm is indicated in the control room. The AFHE high-high-level alarm probe directly cues the operators to the overfilling condition, even though the operators previously failed to terminate the fuel movement manually as planned. In response to the high-high-level alarm probe, the Control Room Operators would be tasked to push the panic button. It is assumed that the probability for failure to act is the controlling probability but that the skin or ball valve must close to terminate the filling. Stopping the cargo pumps is also a way to end the receipt but is not credited since it would not be effective if the filling was accomplished by an inter-tank transfer.

A high-high level alarm mechanical float switch is set at about 22.5 inches above the high-high alarm level probe setting; i.e., 223.82 feet. This switch setting allows ample time for terminating the filling process before the tank level can reach 95% of the current tank overfill level (i.e., at 224.58 feet, less than the overfill level of 250.07 feet for Tank 15, or about 238 feet for the shorter tanks), even if filling was being carried out at the maximum rate (8,300 bbl or 340,300 gallons per hour); i.e., the mechanical float switch settings is selected to terminate the filling before tank level reaches the 95% of the current overfill level, or at approximately 224 feet 6 inches. The mechanical float switch not only detects the higher fuel level but also automatically sends a signal to the affected tank's skin valve to close and to the cargo pumps of that fuel type to trip. These signals are independent of the AFHE system. This automatic action takes just a few minutes to

accomplish, but a delay period is used to allow time for the operators to manually take action. Either closing the skin valve or tripping the cargo pumps, if they were being used, would halt the filling fuel evolution. If the Control Room Operators fail to respond to the AFHE high-high-level alarm probe and the mechanical float actuation trip fails, then no additional credit for the operators revisiting these alarms is made. In that case, the release is governed by the filling terminating when the available source of fuel is depleted. There is a limit on the amount of fuel that can be physically transferred from the source tank to the receiving tank. This is roughly the same as the excess 22,000 bbl or 902,000 gallons assumed as limiting. Therefore, it is extremely unlikely that fuel could ever overflow the top of the dome. Only from a ship or refinery would there be enough fuel supply for that to occur, and those sources would be closely monitored to track the amounts supplied and paid for.

A review of operating records indicates that typical receiving evolutions average about 44,500 bbl or 1,824,500 gallons per receipt. It is conservatively assumed that half of this typical amount of fuel transferred, if erroneously planned, may be in excess of the fuel volume needed to raise levels in the tank to its annual release tightness level of 212 feet. With this assumption, the maximum overfill is limited to 22,500 bbl or 922,500 gallons that could conceivably be added above the annual release tightness level, above which holes developed in the liner would not be detectable. This volume of fuel corresponds to an additional 16 feet of level in the tank above the annual release tightness test level; i.e., to 226.85 feet. This is also a way to estimate the receiving time of the period of overfilling from 212 feet to 226.85 feet; i.e.,  $22,500/2,080 = 10.8$  hours. From 226.85 feet the initial release rate through the hole is 18.93 gpm. The low-level alarm (drop of 0.5 inch) would be reached in about 2.4 hours, and the critical low-level alarm (drop of 0.75 inch) in 3.5 hours. The dynamic low-level alarm is set at a drop of 1 inch for the first 2.5 hours. The release would not cause levels to drop 1 inch until 4.8 hours. Therefore, it is assumed that the dynamic low-level alarm would be reset at 2.5 hours to the static alarm set point of 0.5 inch and require another 2.4 hours before there is another 0.5 inch drop actuating the static alarm; i.e., at a total of 4.92 hours from the time filling is ended.

Assuming 6 hours from the time of the alarm to initiate an evolution to empty the tank, emptying would begin 10.9 hours after the fill ended. Fuel released through the postulated hole would continue for as long as the tank level is above the modeled location of the hole. The release rate increases as the overfilling progresses to the peak fuel level of 228 feet. Even if the mechanical float switch fails and the operators have not intervened by that time, it is assumed there is no more fuel to be transferred to the receiving tank. An overfilling by 22,500 bbl or 922,500 gallons would take more than 10 hours from the time the fuel level reaches the annual release tightness test level. Once the filling (or receipt) is halted, the tank level would drop due to the continued fuel release until the AFHE low-level alarm is reached. The dynamic low-level warning alarm is set at a drop of 1 inch and is active for the first 2.5 hours after the receipt is terminated while the fuel settles out. After 2.5 hours, the low-level warning alarm set point is reset to a level drop of 0.5 inch.

Given the AFHE low-level alarm, the Red Hill gauger/rover would be tasked to manually top-gauge the affected tank. The low-level critical alarm would also provide an indication of the release in progress. Given an AFHE low-level warning or critical alarm, the operators are tasked by procedures to confirm the readings of the AFHE by performing one or more top-gauges manually.

The operators are also tasked to perform a manual top-gauge within 2 hours every time a fuel movement ends. If the AFHE system is working, both that system and confirmation by the top-gauger at Red Hill that there is decreasing fuel level in the tank are needed to confirm that the release is in progress. Once the release is confirmed, Red Hill staff would be tasked to drain fuel from the affected tank to stop the release. It is assumed that it would take 6 hours from the time of the low-level warning alarm to initiate a new fuel evolution to move fuel from the affected tank, thereby lowering the overfilled fuel level. Any of the first four fuel movement approaches described in the first frontline tree discussion (Response to RFI 11 Figure 4, lower panel: Events XFR1, XFR2, XFR3, and XFR4) would also apply here for overfilling events. Again, the fuel offloading rate is assumed to be 2,500 bbl or 102,500 gallons per hour. A key difference is that the amount of fuel that must be moved from the tank subjected to an overfilling with a release would be less, since fuel level only needs to drop below the postulated hole location at roughly 212 feet. Calculations show that if no action was taken to empty the receiving tank, the fuel above the 0.5-inch-diameter hole could release over a period of 65 days.

#### **Scenario #4: Large Release (Nozzle Failure)**

The large discharge scenario involves the hypothetical complete release of the contents of one of the largest fuel storage tanks at the Facility. Each tank has a capacity of up to approximately 302,846 bbl (12,719,532 gallons) of fuel. This highly conservatively scenario assumes that two extremely severe independent events occurred simultaneously: failure of a valve and loss of power at the Red Hill Facility, resulting in the uncontrolled emptying of the tank. In this scenario, fuel would flow down the lower access tunnel and harbor tunnel toward the underground pump house and Adit 2. If all the isolation doors in the tunnel were left open and failed to close due to the power outage, fuel would eventually fill the underground pump house and could escape Adit 1. Fuel could also escape Adit 2, following topographic and drainage features around the Commander, U.S. Pacific Fleet Buildings (352 and 400), and discharging into Halawa Stream via storm water drains. While it is extremely unlikely that a tank failure resulting in the loss of the entire storage capacity will occur, Commander Navy Region Hawaii and federal and state regulators recognize the need to develop these procedures for planning and training purposes. For a detailed description of Oil Spill Response immediate actions, see Appendix B and Appendix F.

## Appendix E: Immediate Response Actions

### **Fuel Department Personnel**

Immediately alert nearby personnel who may be exposed to the effects of the discharge.

Activate nearest fire alarm.

1. Evacuate the Facility, tunnels, and adits.
2. Notify the Control Room Operator.

If properly trained, authorized, and it is safe to do so, initiate available onsite countermeasures (if applicable).

### **Control Room Operator**

1. Stop all fueling operations.
2. Activate emergency shutdown procedures if safe to do so (see Red Plan for procedures).
3. Close all motorized valves on pipelines.
4. Notify the Supervisory Distribution Facilities Specialist, Deputy Fuel and the Fuel Director.
5. Report spill immediately to Regional Dispatch Center.
6. Notify the Commander, U.S. Pacific Fleet Command Duty Officer.
7. Notify Naval Supply Systems Command, Fleet Logistics Center Pearl Harbor Command Duty Officer.
8. Account for the number of personnel (workers and contractors) evacuated.
9. Assess the situation, including:
  - Source and extent of release
  - Status of operation shutdown
  - Number of injured and their conditions
  - Probable direction of vapors
  - Estimate quantity of release
  - Direction of movement of release
  - Status of ignition sources
10. Follow all emergency standard operating procedures.
11. Refer to Red Plan at the beginning of the *Red Hill Response Plan* for additional action.
12. Document all actions.

### **Fuel Director/Emergency Coordinator**

Immediately notify:

- Navy On-Scene Coordinator
- National Response Center
- State Emergency Response Commission
- Local Emergency Response Committee

### **Navy On-Scene Coordinator**

1. Ensure that all proper notifications were made.
2. Activate Navy Supervisor of Salvage to assist Port Operations Facility Response Team.
3. Recall Commander, Navy Region Hawaii (CNRH) Spill Management Team.
4. Establish command center and staging area.
5. Activate emergency response contractors if needed.

### **Safety Officer**

1. Evaluate immediate public health and safety risks.
2. Recommend site control measures to isolate public from possible exposure (such as recommending evacuation or shelter in place).
3. Assess environmental conditions (such as air and water monitoring).
4. Conduct site safety evaluation and develop site safety plan.

### **Initial Response**

The Federal Fire Chief, or senior fire official, will assume the duties of the Incident Command and take control of the spill during the emergency phase. The Federal Fire Department will attempt to control the release, rescue the injured, monitor site safety, and guard against the possibility of fire. A major priority for the Federal Fire Department will be to ensure the safety of the residents of both Joint Base Pearl Harbor-Hickam (JBPHH) and surrounding communities, and to the responders and other emergency personnel.

Due to the nature and volume of the spill, the areas surrounding Adit 1 and 2 at JBPHH and the U.S. Coast Guard housing near the Red Hill Facility may need to be evacuated due to the risks from vapor, fire, and explosions. The Incident Command, in consultation with the Navy On-Scene Coordinator and Safety Officer, will decide if additional evacuations will be needed for the base and surrounding communities.

- If Facility personnel and base residents need to be evacuated, the Incident Command will initiate the evacuation in accordance with the CNRH Emergency Management Plan.
- If communities off-base need to be evacuated the Incident Command will coordinate with the Hawaii Emergency Management Agency and the Honolulu Fire Department in implementing community evacuation plans.

Concurrent with public safety evacuations, the Federal Fire Department will conduct air monitoring at key areas, including the Red Hill Facility, ventilation shafts, and adit entrances.

Once the initial emergency actions are implemented, the Navy On-Scene Coordinator will assume direct control of the spill response and cleanup.

All release response actions will follow the regulations set forth by the *Red Hill Response Plan* (Appendix B) and the Hawaii State Department of Health, State Administrative Rules,

Underground Storage Tank, Chapter 11-280.1, Subchapter 6, Release Response Action (effective January 17, 2020).<sup>16</sup>

<sup>16</sup> <https://health.hawaii.gov/shwb/files/2020/01/11-280.1-Jauary-17-2020-Standard-format-with-summary-and-signature-pages.pdf>

This page intentionally left blank



## Appendix F: Acronyms, Abbreviations, and Initializations

AFHE	Automated Fuel Handling Equipment
ANSI	American National Standards Institute
AOC	Administrative Order on Consent
API	American Petroleum Institute
ASME	American Society for Mechanical Engineers
AST	Aboveground Storage Tank
ATG	Automatic Tank Gauge
BAPT	Best Available Practicable Technology
bbbl	Barrel
BFET	Balanced Field Electromagnetic Technique
BWS	Honolulu City and County Board of Water Supply
CFR	Code of Federal Regulations
CIR	Clean, Inspect, and Repair
CNRH	Commander, Navy Region Hawaii
COPC	Chemical of Potential Concern
CSM	Conceptual Site Model
CSVM	Continuous Soil Vapor Monitoring
DFSP	Defense Fuel Support Point
DIU	Defense Innovation Unit
DLA	Defense Logistics Agency
DoD	Department of Defense
DOH	Hawaii State Department of Health
EPA	Environmental Protection Agency
ESD	Event Sequence Diagram
FC	Facilities Criteria
FOIA	Freedom of Information Act
FTAC	Fuel Tank Advisory Committee
gph	Gallons per Hour
gpm	Gallons per Minute

GWFM	Groundwater Flow Model
GWPP	Groundwater Protection Plan
IRR	Investigation and Remediation of Releases
JBPHH	Joint Base Pearl Harbor-Hickam
L	Liter
L/min	Liters per Minute
LFET	Low Frequency Electromagnetic Technique
LNAPL	Light Nonaqueous-Phase Liquid
MDLR	Minimum Detectable Release Rate
MTG	Multifunction Tank Gauge
NAVFAC	Naval Facilities Engineering Systems Command
NDE	Non-Destructive Examination
NIST	National Institute of Standards and Technology
NSZD	Natural Source-Zone Depletion
O&M	Operations & Maintenance
OD	Outer Diameter
OSHA	Occupational Safety and Health Administration
PAUT	Phased Array Ultrasonic Testing
PID	Photoionization Detector
PLC	Programmable Logic Controller
POL	Petroleum, Oil, and Lubricants
ppbv	Parts per Billion by Volume
ppm	Parts per Million
ppmv	Parts per Million by Volume
PRI	Primary Readiness Index
PTFE	Polytetrafluoroethylene
QRVA	Quantitative Risk and Vulnerability Assessment
RCRA	Resource Conservation and Recovery Act
RFI	Request for Information
SAP	Sampling and Analysis Plan
SOW	Statement of Work

SPAWAR	Space and Naval Warfare Systems Command
SVM	Soil Vapor Monitoring
SVMP	Soil Vapor Monitoring Probe
TIRM	Tank Inspection, Repair and Maintenance
TUA	Tank Upgrade Alternatives
UFC	Unified Facilities Criteria
UFGS	Unified Facilities Guide Specifications
UFM	Unscheduled Fuel Movement
UH	University of Hawaii
UST	Underground Storage Tank
UT	Ultrasonic Technique
VOC	Volatile Organic Compound
XFR	Transfer

This page intentionally left blank

## Appendix G: References

- American Concrete Institute (ACI). 2019. *ACI 364.1R-19: Guide for Assessment of Concrete Structures Before Rehabilitation*. ACI Committee 364.
- Ajami, N. J., Q. Duan, X. Gao, and S. Sorooshian. 2006. "Multimodel Combination Techniques for Analysis of Hydrological Simulations: Application to Distributed Model Intercomparison Project Results." *J. Hydrometeor.* 7 (4): 755–68. <https://doi.org/10.1175/JHM519.1>.
- American Petroleum Institute (API). 2014. *Std 653 - Tank Inspection, Repair, Alteration, and Reconstruction*. 5th Ed. C65305. Includes Addendum 1 Dated April 2018, Addendum 2 Dated May 2020, and Errata 1 Dated March 2020. November.
- Atlas Geotechnical (Atlas), Eastern Research Group ERG Inc. (ERG), PEMY Consulting (PEMY), PEMY, and Powers Engineering and Inspection PEI Inc. (PEI). 2017. *Underground Storage Tank System Evaluation Final Report, Red Hill Bulk Fuel Storage Facility, Joint Base Pearl Harbor-Hickam*. Submitted to: U.S. Environmental Protection Agency, Region 9. June.
- Commander Navy Region Hawaii (CNRH). 2020. *Red Hill Fuel Storage Facility (RHFSF) Response Plan*. August.
- Defense Logistics Agency (DLA). 2019. *DLA Energy P-7, Accountability and Custodial Responsibilities for Defense Working Capital Fund Inventory and Government Property*. May 7.
- Department of the Navy (DON). 2014. *Interim Update, Red Hill Bulk Fuel Storage Facility Final Groundwater Protection Plan, Pearl Harbor, Hawaii. (January 2008)*. Pearl Harbor, HI: Naval Facilities Engineering Command, Pacific. August.
- . 2016. *Red Hill Facility Current Fuel Release Monitoring Systems Report, Administrative Order on Consent (AOC) Statement of Work (SOW), Section 4.3*. 16 August.
- . 2017a. *Red Hill AOC SOW Section 3.0 Tank Upgrade Alternatives (TUA), Red Hill Fuel Storage Facility, NAVSUP FLC Pearl Harbor (PRL), Hawaii*. Final Report, December 2017. Prepared by Enterprise Engineering, Inc., Falmouth, ME.
- . 2017b. *Sentinel Well Network Development Plan, Investigation and Remediation of Releases and Groundwater Protection and Evaluation, Red Hill Bulk Fuel Storage Facility, Joint Base Pearl Harbor-Hickam, O'ahu, Hawai'i; December 11, 2017, Revision 00*. Prepared by AECOM Technical Services, Inc., Honolulu, HI. Prepared for Defense Logistics Agency Energy, Fort Belvoir, VA, under Naval Facilities Engineering Command, Hawaii, JBPHH HI.
- . 2018a. *New Release Detection Alternatives Report, Administrative Order On Consent - Section 4.6, Red Hill Bulk Fuel Storage Facility, Joint Base Pearl Harbor-- Hickam, Hawaii*. 25 July. Prepared for Defense Logistics Agency Energy, Fort Belvoir, VA, under Naval Facilities Engineering Command, Hawaii, JBPHH HI.
- . 2018b. *Groundwater Protection and Evaluation Considerations for the Red Hill Bulk Fuel Storage Facility, Joint Base Pearl Harbor-Hickam, O'ahu, Hawai'i; July 27, 2018, Revision 00*. Prepared by AECOM Technical Services, Inc., Honolulu, HI. Prepared for Defense Logistics Agency Energy, Fort Belvoir, VA, under Naval Facilities Engineering Command, Hawaii, JBPHH HI.

- . 2018c. *Quantitative Risk and Vulnerability Assessment Phase 1 (Internal Events without Fire and Flooding), Red Hill Bulk Fuel Storage Facility, NAVSUP FLC Pearl Harbor, HI (PRL), Joint Base Pearl Harbor-Hickam. November 12, 2018.* Prepared by ABS Consulting, Irvine, CA for HDR Engineering, Inc., Honolulu, HI. ABS Consulting Report No. R-3751812-2043. Administrative Order on Consent In the Matter of Red Hill Bulk Fuel Storage Facility, EPA Docket No. RCRA 7003-R9-2015-01, DOH Docket No. 15-UST-EA-01. JBPHH HI: NAVFAC Pacific.
  - . 2019a. *Conceptual Site Model, Investigation and Remediation of Releases and Groundwater Protection and Evaluation, Red Hill Bulk Fuel Storage Facility, Joint Base Pearl Harbor-Hickam, O'ahu, Hawai'i; June 30, 2019, Revision 01.* Prepared by AECOM Technical Services, Inc., Honolulu, HI. Prepared for Defense Logistics Agency Energy, Fort Belvoir, VA, under Naval Facilities Engineering Command, Hawaii, JBPHH HI.
  - . 2019b. *Red Hill Bulk Fuel Storage Facility Destructive Testing Results Report, AOC/SOW 5.3.3. Site Specific Report, SSR-NAVFAC EXWC-CI-1941. July 7.* NAVFAC EXWC.
  - . 2019c. *Red Hill Bulk Fuel Storage Facility Administrative Order on Consent Tank Upgrade Alternatives and Release Detection Decision Document.* Prepared by Naval Facilities Engineering Command, Hawaii. September.
  - . 2020a. *Groundwater Flow Model Report, Red Hill Bulk Fuel Storage Facility, Joint Base Pearl Harbor-Hickam, O'ahu, Hawai'i; March 25, 2020, Revision 00.* Prepared by AECOM Technical Services, Inc., Honolulu, HI. Prepared for Defense Logistics Agency Energy, Fort Belvoir, VA, under Naval Facilities Engineering Command, Hawaii, JBPHH HI.
  - . 2020b. *Investigation and Remediation of Releases Report, Red Hill Bulk Fuel Storage Facility, Joint Base Pearl Harbor-Hickam, O'ahu, Hawai'i; March 25, 2020, Revision 00.* Prepared by AECOM Technical Services, Inc., Honolulu, HI. Prepared for Defense Logistics Agency Energy, Fort Belvoir, VA, under Naval Facilities Engineering Command, Hawaii, JBPHH HI.
  - . 2020c. *Evaluation of Chromatograms for Understanding TPH Detections in Monitoring Wells, Red Hill Bulk Fuel Storage Facility, Joint Base Pearl Harbor-Hickam, O'ahu, Hawai'i.* Prepared by AECOM Technical Services, Inc. JBPHH HI: Naval Facilities Engineering Command, Hawaii. Final, September.
  - . 2020d. *Section 5.4 Execution Plan, Decision on Need for and Scope of Modified Corrosion and Metal Fatigue Practices.* Administrative Order on Consent In the Matter of Red Hill Bulk Fuel Storage Facility, EPA Docket No: RCRA 7003-R9-2015-01, DOH Docket No: 15-UST-EA-01. NAVFAC EXWC.
  - . 2020e. *Section 8.2: Risk/Vulnerability Assessment Phase 2 Scope of Work, Red Hill Bulk Fuel Storage Facility, NAVSUP FLC Pearl Harbor, HI (PRL), Joint Base Pearl Harbor-Hickam. December 23, 2020.* Prepared by Prepared by Naval Facilities Engineering Command, Hawaii. Administrative Order on Consent In the Matter of Red Hill Bulk Fuel Storage Facility, EPA Docket No. RCRA 7003-R9-2015-01, DOH Docket No. 15-UST-EA-01. JBPHH HI.
- Environmental Protection Agency, United States (EPA). 1999. *Use of Monitored Natural Attenuation at Superfund, RCRA Corrective Action, and Underground Storage Tank Sites.* OSWER 9200.4-17P. Office of Solid Waste and Emergency Response. April.
- . 2019. *Standard Test Procedures for Evaluating Various Leak Detection Methods.* EPA 510-B-19-002 through EPA 510-B-19-006. May.

- Environmental Protection Agency, United States, Region 9; and Department of Health, State of Hawaii (EPA Region 9 and DOH). 2016. *Final Scoping for AOC SOW Sections 6 and 7, and Navy's Proposed Chemical of Potential Concern (COPC) Recommendations*. Letter from: Bob Pallarino, EPA Red Hill Project Coordinator, and Steven Chang, Hawaii DOH Red Hill Project Coordinator, to: James A. K. Miyamoto, Naval Facilities Engineering Command, Hawaii, Joint Base Pearl Harbor-Hickam. February 4.
- . 2017. *Re: Approval of Red Hill Administrative Order on Consent ("AOC") Statement of Work ("SOW") Section 2.4- Tank Inspection, Repair and Maintenance ("TIRM") Procedures Decision Document and Clarifications*. Letter from: Bob Pallarino, EPA Red Hill Project Coordinator, and Steven Chang, Hawaii DOH Red Hill Project Coordinator, to: Capt. Richard D. Hayes, Navy Region Hawaii. September 5.
- . 2018. *Re: Approval of Red Hill Administrative Order on Consent ("AOC") Statement of Work ("SOW") Section 3 -Tank Upgrade Alternatives*. Letter from: Omer Shalev, EPA Red Hill Project Coordinator, and Roxanne Kwan, Hawaii DOH Red Hill Project Coordinator, to: Mark Manfredi, Red Hill Regional Program Director. May 21.
- . 2020a. *Re: Response to Corrosion and Metal Fatigue Practices, Destructive Testing Results Report, Red Hill Bulk Fuel Storage Facility (Red Hill), Joint Base Pearl Harbor-Hickam, Oahu, Hawaii*. Letter from: Steve Linder, EPA Red Hill Project Coordinator, and Roxanne Kwan, Hawaii DOH Interim Red Hill Project Coordinator, to: Captain Marc Delao, Commander Navy Region Hawaii, Joint Base Pearl Harbor-Hickam. March 16.
- . 2020b. *Re: Regulatory Agency Response to Navy Letter Acknowledging Agency Disapproval of the Navy's Corrosion and Metal Fatigue Practices, Destructive Testing Results Report, Red Hill Bulk Fuel Storage Facility (Red Hill), Joint Base Pearl Harbor-Hickam, Oahu, Hawaii*. Letter from: Steve Linder, EPA Red Hill Project Coordinator, and Roxanne Kwan, Hawaii DOH Interim Red Hill Project Coordinator, to: Captain Marc Delao, Commander Navy Region Hawaii, Joint Base Pearl Harbor-Hickam. July 7.
- . 2020c. *Re: Notice of Deficiency for the Tank Upgrade Alternatives Decision Document and New Release Detection Alternatives Decision Document, for Red Hill Administrative Order on Consent Statement of Work Sections 3.5 and 4.8, October 26, 2020*. Letter from: Steven Linder, EPA Red Hill Project Coordinator, and Roxanne Kwan, Hawaii DOH Interim Red Hill Project Coordinator, to: Captain Gordie Meyer, Commander Navy Region Hawaii.
- Michael Baker International (MBI). 2020. *2020 Semi-Annual BFCUST LD Testing Report (JB Pearl Harbor-Hickam HI)*. May. Virginia Beach, VA.
- McHugh, T., C. Newell, B. Strasert, C. Stanley, J. Johnson, T. Henderson, D. Roff, and J. Narusawa. 2020. "Direct Aerobic NSZD of a Basalt Vadose Zone LNAPL Source in Hawaii." *Journal of Contaminant Hydrology* 235 (2020) (103729). <https://doi.org/10.1016/j.jconhyd.2020.103729>.
- Naval Facilities Engineering Command, Engineering and Expeditionary Warfare Center (NAVFAC EXWC). 2016. *Red Hill Facility Tank Inspection, Repair, and Maintenance Report, Administrative Order on Consent (AOC) Statement of Work (SOW), Section 2.2*. Site Specific Report SSR-NAVFAC EXWC-CI-1655. October 11.
- . 2017. *Red Hill Facility Tank Inspection, Repair, and Maintenance Procedure Decision Document, Administrative Order on Consent (AOC) Statement of Work (SOW) Section 2.4*. Site Specific Report SSR-NAVFAC EXWC-CI-1745. April 24.
- . 2018. *Red Hill Alternative Location Study*. Revision 03. Submitted by Austin Brockenbrough, Richmond, VA. February 5.

PEMY Consulting. 2015. *Catastrophic Release Potential at Red Hill Fuel Storage Facility*. Contract No. EP---R9---15---01, Sequential Deliverable No. 3. Via Email to: Tom Huetteman, Steven Linder, Omer Shalev, and Bob Pallarino. 15 September.

Wiedemeier, T. H., H. S. Rifai, C. J. Newell, and J. T. Wilson. 1999. *Natural Attenuation of Fuels and Chlorinated Solvents in the Subsurface*. New York: John Wiley & Sons, Inc.